

**Model 6210
Galvanometer Optical Scanner**

INSTRUCTION MANUAL

**CAMBRIDGE TECHNOLOGY, INC.
109 Smith Place
Cambridge, MA 02138
U.S.A.**

TEL.617-441-0600 FAX.617-497-8800

Revision 0, February 10, 1999

1.0. Introduction and Warnings

This manual was written to help the customer use the Model 6210 scanner successfully. There are several warnings and precautions written throughout this manual. Read this manual carefully. It is possible to damage the scanner by exposing it to rough handling or contaminants.

As the demand for speed and accuracy of today's optical systems increases, so does the need for high performance, high accuracy scanners. This scanner was designed for just those applications that require ultra-high speed and accuracy.

Note: Throughout this manual the terms mechanical angle and optical angle will be used. For all applications the mechanical angle refers to the angular change of the scanner shaft. For most optical systems the optical angle is the angular change of the beam. For these optical systems, the:

$$\text{optical angle} = 2 \times \text{mechanical angle}$$

WARNING!!!! Upon system shutdown or malfunction, the scanner has the ability to point the beam anywhere within $\sim 200^\circ$ optical. It is up to the end user to limit the exit window of the laser beam in order to provide laser safety.

*****CAUTION!!!** Ensure that the scanner and/or the XY mount has adequate heatsinking to allow scanner operation. Never operate the scanner without a heatsink!! The scanner will suffer irreparable damage if allowed to overheat!! For more information, refer to section 3.2. The Cambridge Technology XY mount is a sufficient heatsink only if bolted to a customer supplied adequate heatsink to conduct away the heat.

Note: These scanners are high performance devices that require some special handling. Never let them impact a hard surface especially on the front shaft. Do not pull or push with anything other than light finger pressure on the front shaft or damage to the front bearing can occur. Do not turn the scanner into the bumper stop with any torque whatsoever or the PD will be permanently damaged. Do not expose the scanner to extremes of temperature outside the operating limits shown in the specifications section 2.0. Do not let any foreign material, e.g. dust, dirt, solvent, water, oil, etc. come in contact with the front bearing. It is located right at the front end of the scanner. Foreign material inside the bearing will reduce bearing life.

Note: As with any high performance motor, resonances created during power up, power down, normal operation, or during tuning can cause serious motor degradation or failure. Always keep the motor under proper servo control and do not let the motor swing uncontrolled into the bumper stops.

2.0. Specifications

Note: All angles are in mechanical degree unless stated otherwise.

<u>Scanner MODEL NO.</u>	<u>6210</u>	<u>Tolerance</u>	<u>Units/Notes</u>
<u>Mechanical Specifications</u>			
Rated Excursion, Rotor	+/-20	Max	degrees
Bumper Stop Angle, Initial Contact	+/-26	+/-4	degrees
Maximum penetration into the bumper	14	Max	degrees
Optical Aperture, Two-Axis, std.	3	Max	millimeters
Rotor Inertia	0.020	+/-10%	gm-cm ²
Recommended Load	0.000 - 0.20	-	gm-cm ²
Torque Constant	2.5E+04	+/-10%	dyne-cm/amp
Coil Resistance	4.1	+/-10%	ohms
Coil Inductance	98	+/-10%	μhenries
Back EMF Voltage	43.6	+/-10%	μv/degrees/s
Thermal Resistance, Coil-to-Case	4	Typ	°C/watt
Maximum Coil Temperature	110	Max	°C
Maximum RMS Current	1.60	Max	amps
Maximum Peak Current	6	Max	amps
Maximum RMS Power	15	Max	watts
Fuse rating	2.5	-	amps, fast-blo
Settling time	300	Typ	μseconds ²
Scanner Weight	17	Typ	grams
<u>Position Detector, PD³</u>			
Linearity	99.5	Min	% over 40°
Scale Drift	50	Max	PPM/°C
Zero Drift	25	Max	uradians/°C
Repeatability, Short Term	15	Max	μrad.
Output Signal, Diff. Mode	{ 11.7	+/-5%	μA/° diff.@
Output Signal, Common Mode	{ 155	Nom	μA @I _{LED} = 30ma +/-20%
PD Power Requirements	{ 30	+/-20%	milliamps, DC
	{ 1.4	Nom	volts

Mounting requirements: The scanner mount must dissipate 1.5 watt/°C. for a mount temperature of 40°C. In an XY mount, it must dissipate 3.0 watt/°C for a mount temperature of 40°C. See section 3.2 for more information.

1. Cross pin prevents PD error due to hitting bumper.
2. Setup for settling time: 0.002 gm-cm² load moving through a 5° step and settling to within 99% of final position.
3. Using the Cambridge Technology, Inc. Position Demodulator circuit.

3.0 Description of Operation

3.1 Overview

The 6210 is a moving-magnet actuator, that is the rotor or working part of the scanner is a magnet. A moving magnet motor has no saturation torque limit and very little electrical inductance. Thus extremely high torque can be generated very quickly. This is essential for systems that need short step response times.

There are two practical factors that limit the amount of torque that can be generated by a moving magnet scanner. The peak torque is limited by the mechanical failure limit of the rotor assembly due to stator current in excess of the peak current specification. The rms torque is limited by the maximum power (I^2R losses in the stator coil) the scanner can conduct away. When the maximum rms current has been reached (with adequate heatsinking) the stator has reached its maximum temperature, and thus the motor has reached maximum rms torque level. Extremely high performance can be achieved in part because both the peak torque limit and maximum power that the stator coil can dissipate are very high.

The angular position of the shaft is detected by an optical sensor located on a small circuit card, the position detector board, on the back of the scanner. The output signal of this sensor is a differential current signal that is fed back to the drive electronics, closing the servo loop, and allowing very fast and accurate mirror positioning. A typical position demodulator circuit is included with this manual. Cambridge Technology strongly recommends using this circuit to all customers that do not buy the CTI driver electronics.

3.2. Mounting Scheme

Special attention should be given to the mechanical integration of the scanner into the optical system. The customer must provide an adequate path for conducting away the heat generated by the scanner body. The maximum temperature that the scanner body should be allowed to attain is 50°C. This is below the temperature at which a person feels pain, thus the scanner should **never** get too hot to touch! The XY mount should ideally have very low thermal resistance to the ambient temperature. Refer to the specifications section for the minimum heat sinking requirement.

Note: The amount of heatsinking necessary is affected by the ambient temperature of the optical enclosure. At an ambient temperature of 50°C the scanner mount's thermal resistance would have to be zero to run the scanner at its maximum rating.

For the 6210 scanner, the only valid mounting surface is the long cylindrical section of the body. See the outline drawing at the end of this manual. The scanner must be mounted by this surface to adequately transfer the heat out. A cylindrical, compression-style mount made of aluminum is preferred. The mount should attempt to contact as much of the mounting surface as possible to minimize the thermal resistance. The mount should then be bolted to another thermally conductive plate to finally conduct the heat away to ambient. **Never attempt to mount the scanner by its position detector any other surface than just described or serious overheating will occur!!**

Caution!!! Never run the scanner without a heatsink attached. The scanner body will heat very quickly and irreparable damage will occur, thus voiding the warranty.

Caution!!! Do not tighten the mount's clamping screw beyond the maximum recommended torque, otherwise the scanner's body could be damaged.

3.3. Cabling

The Model 6210 motor has been optimized to be as small as possible. The present design employs direct cabling to minimize the overall package size. Thus, depending on the order presented to Cambridge Technology, Inc., the scanner may arrive to the customer with or without a cable.

If the scanner arrives with a cable, be careful not to stress the connections of the cable near the scanner end. The wires may break which could cause scanner failure or damage. Always secure the cable when integrating the scanner into the system in such a manner that prevents excessive strain on the PD board. Any force on the PD board may cause the scanner to shift position.

If the scanner was ordered without a cable, the cable length needs to be changed, or if the cable is damaged and the customer wants to repair it, refer to the following procedure for soldering the cable to the scanner connector. The standard cable for the 6210 is the 6010-8L-XXX cable. The -XXX refers to the length of the cable in inches.

3.3.1. Wiring Instructions for the 6010-8L Cable Assembly

Please read this entire procedure before performing any tasks. All aspects must be clearly understood before proceeding.

3.3.1.1. Attaching the Cable to the Motor

This procedure should be used when the cable end to be attached to the motor has been properly prepared. The cable is properly prepared when it leaves Cambridge Technology, but if the cable length needs to be modified, or if a wire is damaged during assembly, refer to "**Modifying the Cable Length,**" shown below.

Materials Required:

- 1.) Soldering iron with a small width tip
- 2.) Solder
- 3.) Wire cutters - small

Procedures:

- 1.) Before attaching the cable to the motor ensure that holes X, X, and X through XX have been properly de-soldered. There should be no solder left in these holes. DO NOT de-solder holes 3 through 6. These are for internal connections within the motor and must be left connected.
- 2.) Refer to Wiring Diagram drawings #D03762 to show the proper connections for the respective cable purchased. Be careful to follow the wiring diagram exactly.

Caution!!! If a wiring mistake is made, the scanner could be damaged!!

- 3.) When soldering the connections, use caution to avoid overheating the individual wires. Their insulation is fragile and easily damaged. The wires should enter the board from the side of the scanner's rear cover. Apply heat and the solder from the other side of the board. Use caution not to solder bridge between the pads or the scanner housing.
- 4.) Cut off any excess wire that protrudes from the far side of the soldered hole to minimize the possibility of shorting.
- 5.) Do not attempt to clean the flux off of the solder connections. The cleaner may enter the scanner and contaminate it.
- 6.) Strain relief the finished cable assembly near the scanner as needed. This will keep undue strain off the soldered connections. Do not attach any kind of strain relief to the motor itself.

3.3.1.2. Modifying the Cable Length

This procedure should be used when the length of the cable provided is too long or has become damaged and needs repair.

Materials Needed:

- 1.) Soldering iron with a small width tip
- 2.) Solder
- 3.) Wire cutters – small
- 4.) Wire strippers for wire #18awg to #24awg
- 5.) Heat gun
- 6.) Heat shrink tubing kit provided with the 6010-8L cable
 - a.) 1/16" wide by 5/8" long
 - b.) 3/16" wide by 1" long

Procedures:

- 1.) Cut the cable to the desired length as measured from the end of the 9 Pin D-connector to the end to be prepared. Ensure both cables are cut to the same length or uneven tension will be placed on the wires after soldering.
- 2.) Use one piece of 3/16" wide by 1" long heat shrink tubing on each cable and slide them up the cable about 3 – 4 inches. Do not shrink the tubing at this time.
- 3.) Carefully cut 3/8" of the jacket off the cables without "nicking" the insulation of the wires within. Strip off the foil shield within each cable
- 4.) On the two conductor cable, cut the drain wire off at the point the jacket ends. The drain wire is the one without insulation.
- 5.) On the four conductor cable, twist the drain wire naturally, and slide the 1/16" wide by 5/8" long heat shrink tubing on it. Leave about 1/8" of bare wire exposed at its end.
- 6.) Heat the 1/16" piece of tubing at this time.
- 7.) Strip 1/8" of insulation from the other four conductors of this cable and the two conductor of the other cable. On 6010-8L's all six conductors are #24awg. Tin the exposed ends of all conductors. Do not use excessive solder or the wires may not pass through the holes in the scanner's position detector board. Use only enough solder to hold the wires together, but not so much that you cannot see the individual wires.

- 8.) Slide the 3/16" heat shrink tubing back down the cables so that only 3/16" of insulation from the individual wires is exposed. Ensure that an adequate length of wire has been left so that each can reach its respective hole on the scanner. Heat the 3/16" tubing at this time. Do not melt the wire insulation, it is fragile.

3.4. Mirrors

The 6210 is designed to have the mirror glued directly into a slot in the end of the output shaft. The standard slot width is shown in the outline drawing in section 5.1. Other custom slot widths are available, but contact Cambridge Technology, Inc. directly for availability.

This direct gluing method negates the need for a removable mirror mount. This minimizes the extra inertia required to hold the mirror in a removable mount. Mirror alignment is ensured by close tolerancing of the slot's position, and by a mirror alignment fixture. This fixture slips over the front of the motor and holds the mirror in position during gluing. The Mirror Alignment Kit, 6200MRK is not included standard with a 6210, but is offered as an option. The 6200MRK is designed for the 3mm aperture, +/-30° optical mirror set. The kit includes a mirror alignment fixture (one end is for the X mirror and one for the Y), two 3mm aperture X and Y mirrors, a large supply of appropriate epoxy, and a written procedure on the gluing operation. **Note: Use the glue sparingly! Do not get the glue into the front bearing!!**

3.5. XY Mounts

There are two standard XY mount designs built for the 6210. They are specifically designed for maximum heat dissipation into the mounting surface the XY mount is bolted to, and to minimize overall volume. These mounts also allow for top or bottom mounting.

Each XY mount is designed to accept a 3mm clear aperture. For normal scanning angles the 6102103R and L are mounts that take a 3mm beam and scan it through +/-15° mechanical. For applications that require the ultimate in speed, and allow smaller scan angles there are the 6102103R-40 and 6102103L-40. All four variations are either right- or left-handed. This is to accept beams from either the right or the left and project the beam straight ahead.

Note: CTI XY mounts are designed with the X-scanner tipped back to minimize the inertia of the Y-mirror. The beam still exits the XY mount parallel to the bottom mounting surface. See the two XY Mount Interface Dwg. in appendix 5.1.

4.0. Limited Warranty

The 6210 scanner is warranted to be free of defects in materials and workmanship for one year from the date of shipment. Cambridge Technology, Inc. will repair or replace, at our option, any part of the system which upon our examination is found to be defective while under warranty. Obligations under this warranty are limited to repair or replacement of the equipment. Cambridge Technology shall not be liable for any other damages of any kind, including consequential damages, personal injury, or the like. Opening the scanner assembly itself will void this warranty. Damage to the system through misuse will void this warranty. Cambridge Technology pursues a policy of continual product development and improvement. We reserve the right to change published specifications without prior notice.

5.0 Appendix

5.1. Schematics and Mechanical Drawings

The following drawings are included in this section

- | | |
|---|--------|
| 1. Series 6000 Position Demodulator Components | D01747 |
| 2. 6210 Outline Drawing | D03628 |
| 3. 6210 Preferred Mounting Block | D03800 |
| 4. 62XX/6010-8L Wiring Diagram | D03762 |
| 5. 6210 Right Handed 3mm XY Mount Interface Dwg | D03793 |
| 6. 6210 Left Handed 3mm XY Mount Interface Dwg | D03807 |
| 7. 6210 Right Handed 3mm +/- 10°m Interface Dwg | D03863 |
| 8. 6210 Left Handed 3mm +/-10°m Interface Dwg | D03869 |

These drawings and specifications are the property of CAMBRIDGE TECHNOLOGY and shall not be reproduced, or copied, or used as the basis for the manufacture, or sale of apparatus without the written permission of CAMBRIDGE TECHNOLOGY, INC.

REVISION				
ECO	REV	DESCRIPTION	APPR	DATE
-	B	.88 WAS .89, .95 WAS .96	PTH	10/98
-	C	.043 ^{+.002} _{-.001} WAS .034 ^{+.002} _{-.001} , ROT 90°	PTH	2/99

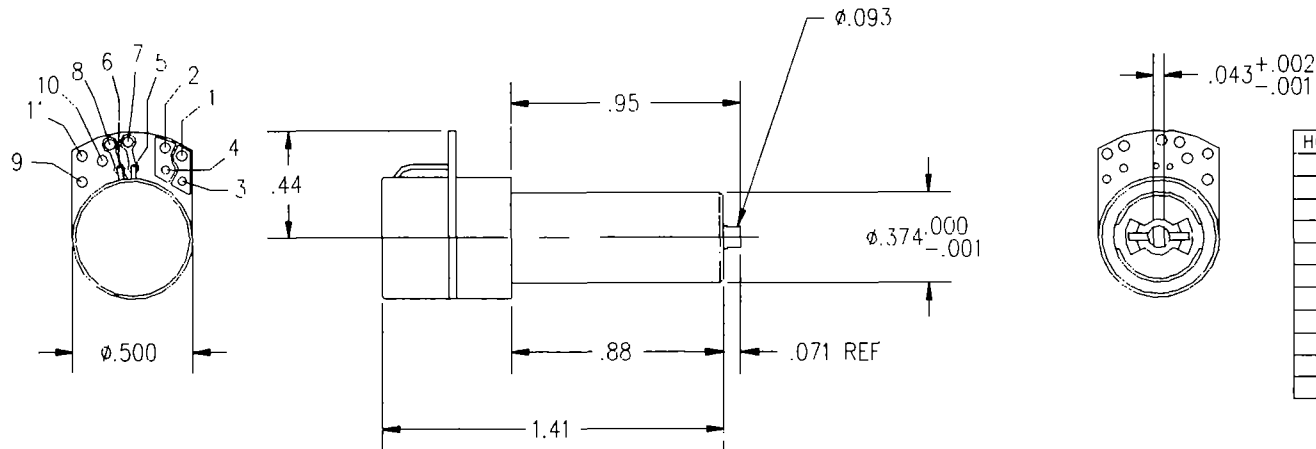

HOLE #	DESCRIPTION
1	+MOTOR
2	-MOTOR
3	+MOTOR (INTERNAL CONNECTION)
4	-MOTOR (INTERNAL CONNECTION)
5	LED1 ANODE (INTERNAL CONNECTION)
6	LED1 CATHODE (INTERNAL CONNECTION)
7	ACC OUT
8	DIODE COMMON
9	Ia
10	Ib
11	SHIELD

(ALL DIMENSIONS ARE IN INCHES)
MASS = 17 GRAMS

	UNLESS OTHERWISE SPECIFIED	DRN		CAMBRIDGE TECHNOLOGY, INC.
	TOLERANCES	DES		109 SMITH PLACE
	.XX±.010	CHK		CAMBRIDGE, MA. 02138 - USA
	.XXX±.005	ENG		6210 OUTLINE DWG.
	() INDICATES mm	APPR		
	ANGLES± 0°-30°	PROJECTION		D03628
	SURFACE ROUGHNESS 6.3			
	BREAK ALL SHARP EDGES			SCALE NONE
	MATERIAL	REVISION		SHEET 1 OF 1
USED ON	FINISH	C		

These drawings and specifications are the property of CAMBRIDGE TECHNOLOGY and shall not be reproduced, or copied, or used as the basis for the manufacture, or sale of apparatus without the written permission of CAMBRIDGE TECHNOLOGY, INC.

REVISION				
ECO	REV	DESCRIPTION	APPR	DATE

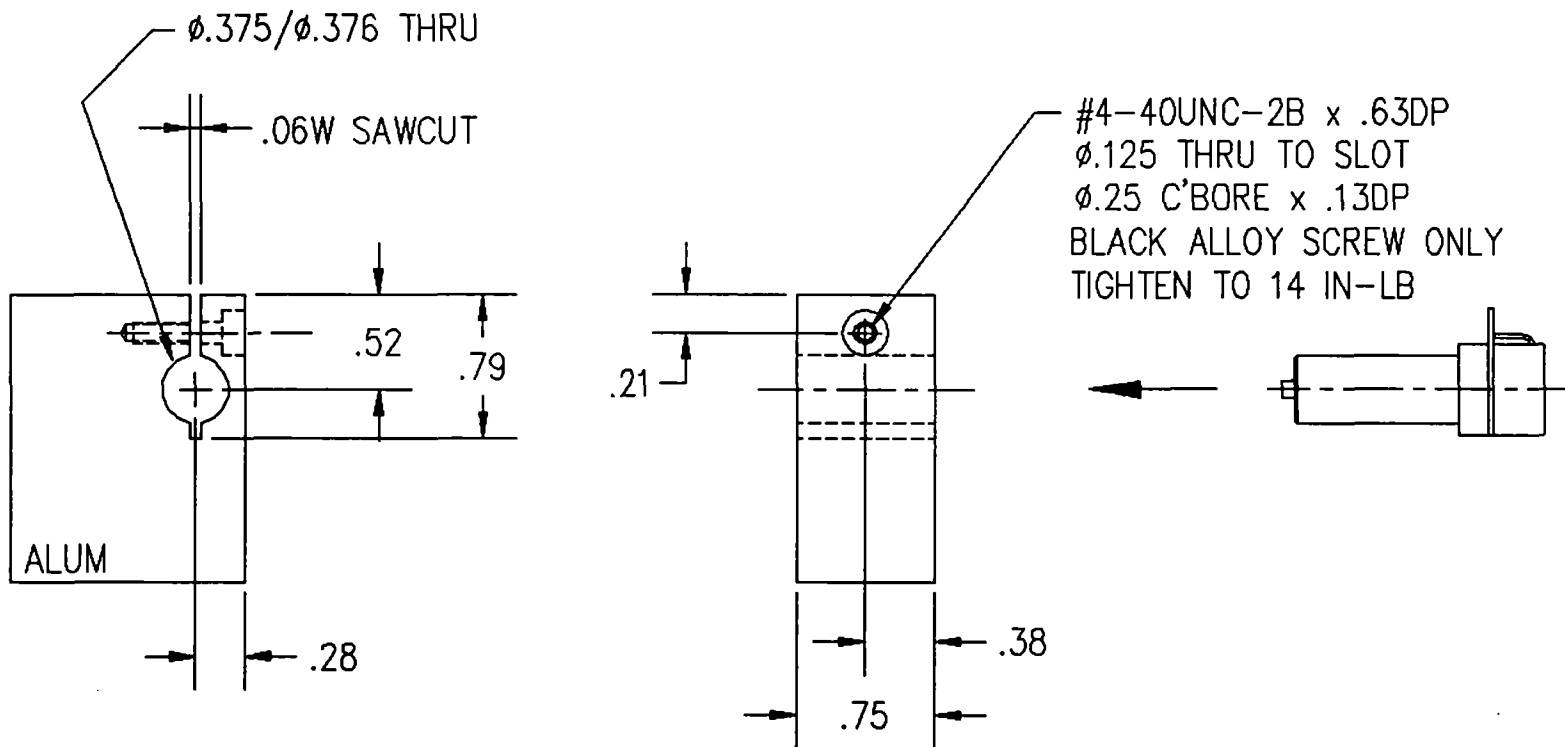

UNLESS OTHERWISE SPECIFIED TOLERANCES $.XX \pm .010$ $.XXX \pm .005$ () INDICATES mm ANGLES $\pm 0^\circ - 30'$	DRN	02/11/99	PTH	CAMBRIDGE TECHNOLOGY, INC. 109 SMITH PLACE CAMBRIDGE, MA. 02138 - USA
	DES			
	CHK			6210 PREFERRED MOUNTING SCHEME
	ENG			
	APPR			
MATERIAL	PROJECTION 			D03800
FINISH	REVISION	A		
SCALE ; NONE		SHEET 1 OF 1		

These drawings and specifications are the property of CAMBRIDGE TECHNOLOGY and shall not be reproduced, or copied, or used as the basis for the manufacture, or sale of apparatus without the written permission of CAMBRIDGE TECHNOLOGY, INC.

REVISION				
ECO	REV	DESCRIPTION	APPR	DATE
1453	B	PINS 9,10 & 11 CORRECTED	PTH	5/99

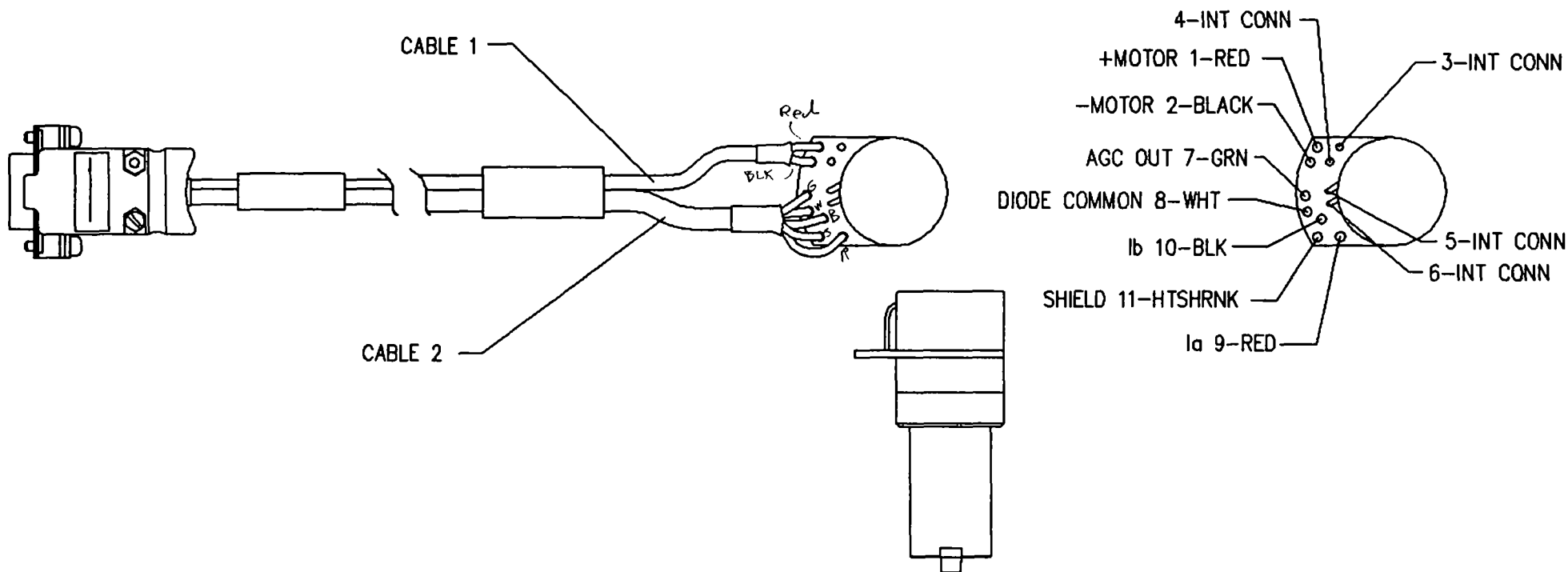

HOLE #	CBL #	WIRE COLOR	DESCRIPTION
1	1	RED	+MOTOR
2	1	BLACK	-MOTOR
3	-	-	INTERNAL CONNECTION
4	-	-	INTERNAL CONNECTION
5	-	-	INTERNAL CONNECTION
6	-	-	INTERNAL CONNECTION
7	2	GREEN	AGC OUT
8	2	WHITE	DIODE COMMON
9	2	RED	Ia
10	2	BLK	Ib
11	2	HTSHRNK	SHIELD

UNLESS OTHERWISE SPECIFIED TOLERANCES .XX±.010 .XXX±.005 () INDICATES mm ANGLES± 0°-30° SURFACE ROUGHNESS 63 BREAK ALL SHARP EDGES	DRN 12/30/98	PTH	CAMBRIDGE TECHNOLOGY, INC. 109 SMITH PLACE CAMBRIDGE, MA. 02138 - USA
MATERIAL	DES	CHK	
FINISH	ENG	APPR	62XX/6010-8L WIRING DIAGRAM
USED ON	PROJECTION	REVISION	
		B	D03762
			SCALE: NTS SHEET 1 OF 1

These drawings and specifications are the property of CAMBRIDGE TECHNOLOGY and shall not be reproduced, or copied, or used as the basis for the manufacture, or sale of apparatus without the written permission of CAMBRIDGE TECHNOLOGY, INC.

REVISION				
ECD	REV	DESCRIPTION	CHK	DATE

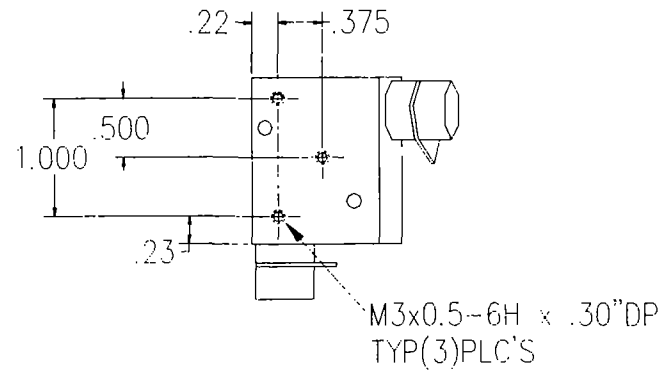
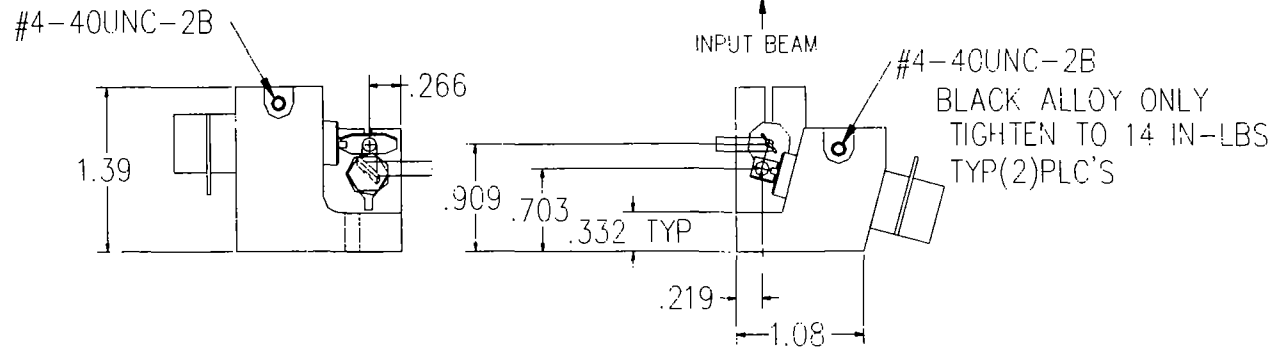
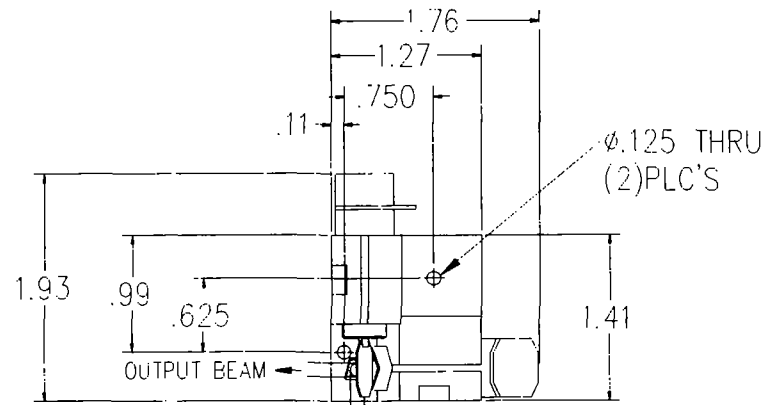

UNLESS OTHERWISE SPECIFIED	DESN 07/26/98	PIN	CAMBRIDGE TECHNOLOGY, INC.
TOLERANCES	DES		100 SMITH PLACE
.XX = ±0.010	CHK		CAMBRIDGE, MA 02138 - USA
.XXX = ±0.005	ENG		6210 XY INTERFACE RH
() INDICATES mm	APPR		3mm ±15' MECH
ANGLES: 0°-30°	PROJECTION	⊕	
SURFACE ROUGHNESS	REVISION	A	D03793
BREAK ALL SHARP EDGES			SCALE: 2:1 SHEET 1 OF 1
MATERIAL			
FINISH			

These drawings and specifications are the property of CAMBRIDGE TECHNOLOGY and shall not be reproduced, or copied, or used as the basis for the manufacture, or sale of apparatus without the written permission of CAMBRIDGE TECHNOLOGY, INC.

REVISION				
ECO	REV	DESCRIPTION	CHK	DATE

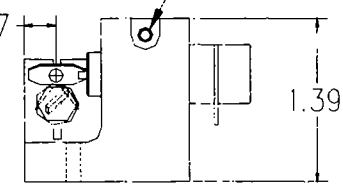
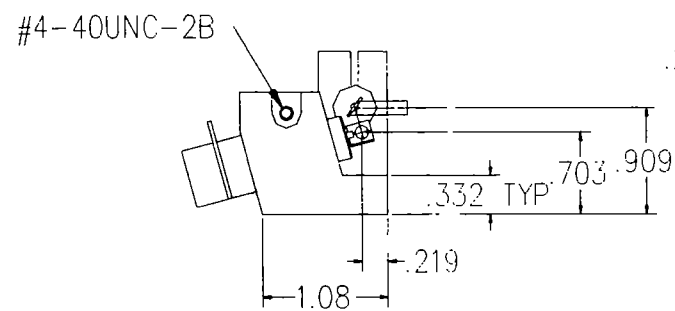
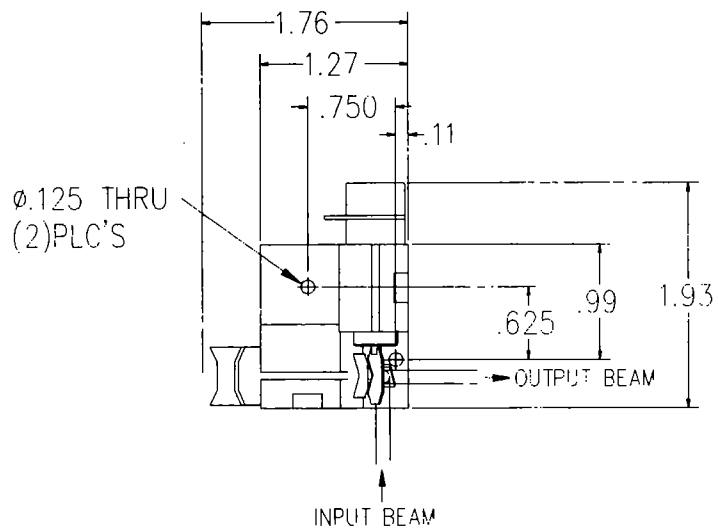

#4-40UNC-2B
BLACK ALLOY ONLY
TIGHTEN TO 14 IN-LB
TYP(2)PLC'S

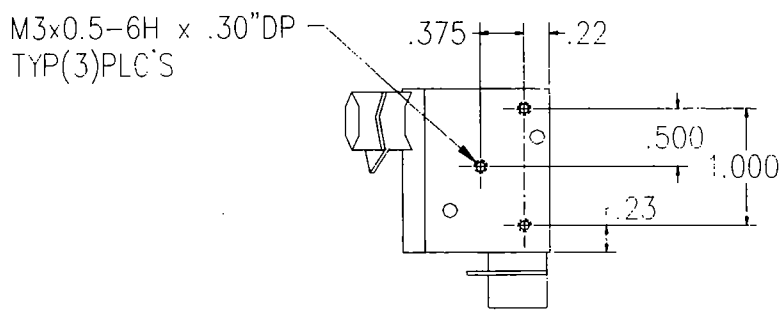

UNLESS OTHERWISE SPECIFIED	DRN	02/01/90	PH	CAMBRIDGE TECHNOLOGY, INC.
TOLERANCES	DES			109 SMITH PLACE
XX = ±0.010	CHK			CAMBRIDGE, MA 02138 - USA
.XXX = ±0.005	ENG			6210 XY INTERFACE LH
() INDICATES mm	APPR			3mm ±15' MECH
ANGLES: 0°-30°	PROJECTION			
SURFACE FINISH	REVISION			D03807
BREAK ALL SHARP EDGES	A			SCALE: 2x SHEET 1 OF 1
MATERIAL				
FRESH				

These drawings and specifications are the property of CAMBRIDGE TECHNOLOGY and shall not be reproduced, or copied, or used in the form for the manufacture, or sale of apparatus without the written permission of CAMBRIDGE TECHNOLOGY, INC.

REVISION			
REV	REV	DESCRIPTION	DATE

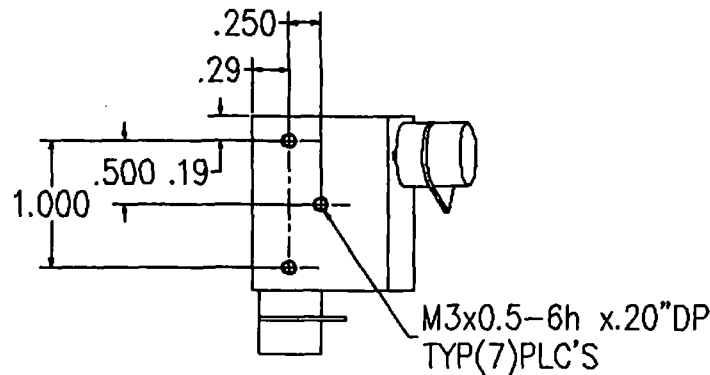
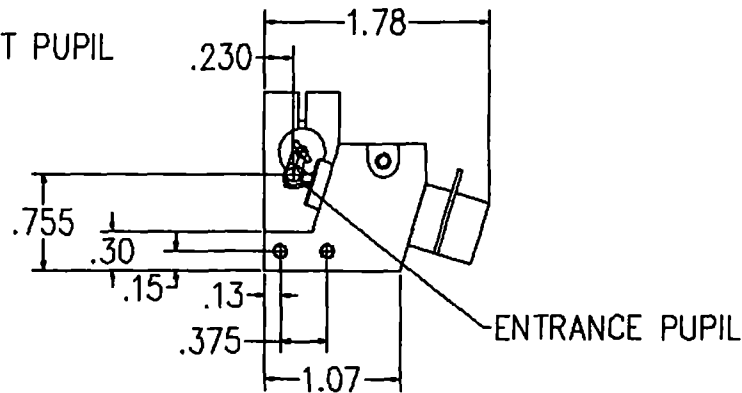
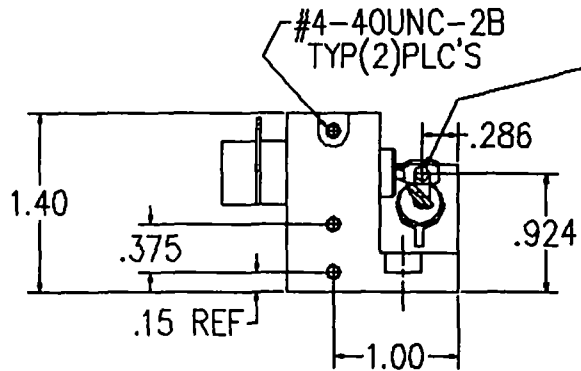
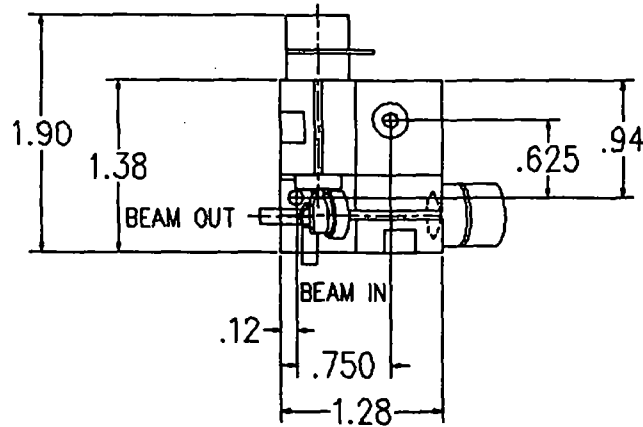

DESIGN OTHERWISE SPECIFIED	REV. 01/28/78	EN	CAMBRIDGE TECHNOLOGY, INC.
TOLERANCES			100 BATH PLACE
			CAMBRIDGE, MA 02139 - USA
			6210 XY INTERFACE R-1
			(17° TILT ANGLE)
			3mm ±10% MECH
			D03863
MATERIAL	REVISION		
FINISH	A		
USED ON			

These drawings and specifications are the property of CAMBRIDGE TECHNOLOGY and shall not be reproduced, in whole or in part, or used in the manufacture or sale of equipment without the written permission of CAMBRIDGE TECHNOLOGY, INC.

REVISION				
NO	REV	DESCRIPTION	CHK	DATE

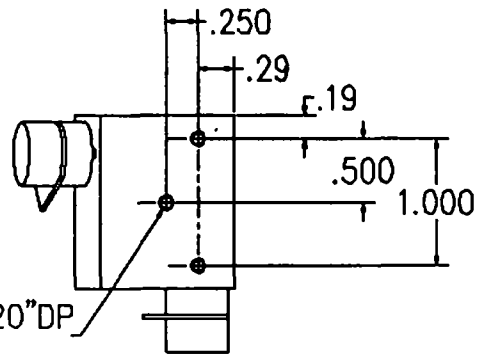
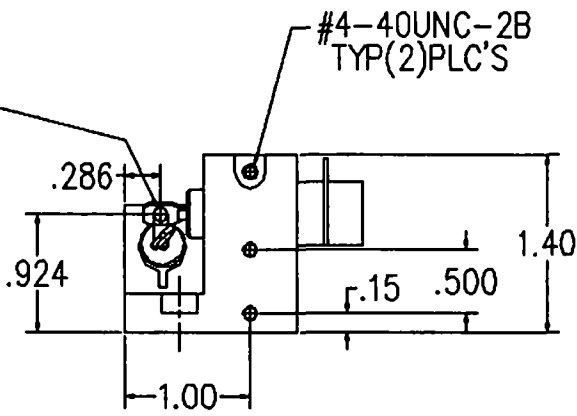
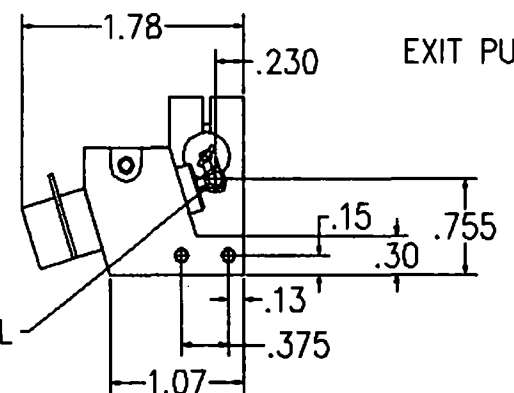
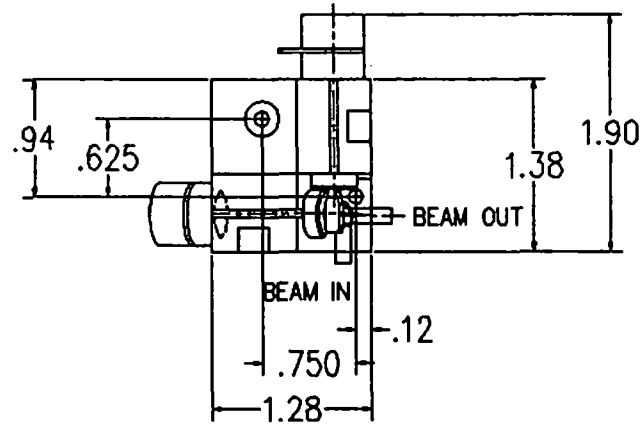

M3x0.5-6h x.20"DP
TYP(7)PLC'S

UNLESS OTHERWISE SPECIFIED	DATE 02/20/88	FIG	CAMBRIDGE TECHNOLOGY, INC.
TOLERANCES			100 THIRD PLACE
			CAMBRIDGE, MA 02142 - USA
			0210 XY INTERFACE LH
			(17° TILT ANGLE)
			3mm ±10' MECH
			D03889
MATERIAL	REVISION		SCALE: 1" = 1"
FINISH	A		SHEET 1 OF 1