

0.1 EC Declaration of Conformity

We: **FHC Europe (TERMOBIT PROD srl)**

of:

**129 Barbu Vacarescu Str, Sector 2
Bucharest 020272
Romania**

declare that:

Equipment: Temperature Regulation Systems

Model: Catalog No.s 40-90-8D, 40-90-5D-02, 40-90-3, 40-90-6, 40-90-2-XX

Serial Number: 19683

has been designed and manufactured to the following specifications:

IEC61326 Electrical Equipment for Measurement, Control, and Laboratory Uses

I hereby declare that the equipment named above has been designed to comply with the relevant sections of the above referenced specifications. The unit complies with all essential requirements of the Directives.

Signed by: _____ *FHC* 2008.03.03 Date: _____
Name: Frederick Haer 09:32:46 -
05'00'

Position: President , FHC

Done at: *FHC Inc., 1201 Main Street, Bowdoin, ME 04287 USA*

Phone: 1207-666-8190, Fax: 207-666-8292



E-mail: *fhcinc@fh-co.com*, Website: *http://www.fh-co.com*

QUALITY INSPECTION SUMMARY

We have made every effort to manufacture this instrument to the highest quality standards. All assemblies have been thoroughly tested and inspected at the factory as follows:

Initial Assembly Inspection	<u>LS</u>	<input checked="" type="checkbox"/>
Initial QC Inspection/Calibration	<u>LS</u>	<input checked="" type="checkbox"/>
24 Hour Burn-In	<u>LS</u>	<input checked="" type="checkbox"/>
Final Performance Inspection	<u>LS</u>	<input checked="" type="checkbox"/>

Packaging Inspection

Initials: JB Date: 9.2.08

Items included with any catalog number may be labeled and packaged separately in shipping carton.

Description	Quantity	Checked
Cat.#40-90-8D DC Temperature Controller Module		<input checked="" type="checkbox"/>
Containing:		
Controller Module	<u>1</u>	<input checked="" type="checkbox"/>
Junction Box	<u>1</u>	<input checked="" type="checkbox"/>
Accessory Kit	<u>1</u>	<input checked="" type="checkbox"/>
Specified Line Cord	<u>1</u>	<input checked="" type="checkbox"/>
Cat.#40-90-2X Heating Pad		<input checked="" type="checkbox"/>
Cat.#40-90-5D-02 Thermistor Probe		<input checked="" type="checkbox"/>
Cat.#40-90-3 Heating Rod		<input type="checkbox"/>
Cat.#40-90-6 Liquid Thermistor		<input type="checkbox"/>

TO SPECIFY FHC CONCENTRIC BIPOLAR ELECTRODES:

CATALOG # **CB 123456**
 Concentric Bipolar Electrode Configuration Length

n/n/n... or
 (iin)
 Modifier(s)

Modifier Note:
 Any 'X's in the catalog # indicate that modifiers are required. Specify Extension and Protrusion if needed, or initials will reference a drawing with all specifics detailed.

1 Outer Pole Diameter:

- Outer Pole is a stainless steel tube.
 A: 125 µm (35 ga)
 B: 200 µm (33 ga)
 C: 250 µm (31 ga)
 D: 300 µm (30 ga)
 E: 325 µm (29 ga)
 F: 400 µm (27 ga)
 G: 450 µm (26 ga)
 H: 500 µm (25 ga)
 J: 550 µm (24 ga)
 X: Special / Specify

2 Tip Configuration:

- R: Rounded
 Specify Height (50% Outer Dia Standard)
 F: Flat
 M: Microelectrode
 Specify Microelectrode and extension. (100 µm standard; Ø must be > 50 µm)
 P: Pencil Point
 Specify angle. (60° Standard)
 E: Extended
 Specify Extension (100 µm standard)
 B: Beveled
 Specify angle (45° Standard)
 S: Stacked, specify both inner and outer pole exposures and extension. (100 µm standard on all 3)
 X: Special / Specify

50% of Outer Pole diameter height standard (Specify other if needed.)

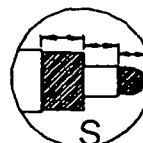
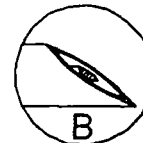
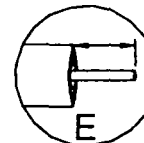
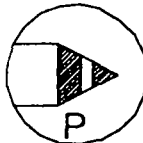
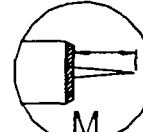
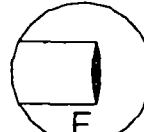
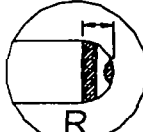

60° Angle standard (Specify other if needed.)

100 µm standard (Specify other if needed.)

45° Angle standard (Specify other if needed.)

100 µm exposures. 100 µm separation standard. (Specify others if needed.)

3 Inner Pole Wire Diameter:

Size / Material:
 (See note on right for listing of the maximum sizes allowed for a given Outer Pole diameter.)

- B: 12.5 µm dia. Platinum/Iridium
 C: 25 µm dia. Platinum/Iridium
 D: 25 µm dia. Stainless Steel
 E: 50 µm dia. Platinum/Iridium
 F: 50 µm dia. Stainless Steel
 G: 75 µm dia. Platinum/Iridium
 H: 75 µm dia. Stainless Steel
 J: 125 µm dia. Platinum/Iridium
 K: 125 µm dia. Stainless Steel
 L: 250 µm dia. Platinum/Iridium
 M: 250 µm dia. Stainless Steel
 X: Special / Specify

Note:
 Largest Inner Pole diameter allowed for Outer Pole O D

Outer Pole Ø	Max. Inner Pole Ø
A: 125 µm	25 µm (0.001")
B: 200 µm	50 µm (0.002")
C: 250 µm	75 µm (0.003")
D: 300 µm	75 µm (0.003")
E: 325 µm	125 µm (0.005")
F: 400 µm	125 µm (0.005")
G: 450 µm	200 µm (0.008")
H: 500 µm	250 µm (0.010")
J: 550 µm	250 µm (0.010")

4,5,6

Length (in millimeters)

75 mm Standard and in stock. See diagram below for dimension definition. No leading zero is necessary.

PRICING:

1 Outer Pole Diameter:

- A: \$65.00 ea.
 B: \$39.00 ea.
 C: \$37.00 ea.
 D: \$35.00 ea.
 E: \$32.00 ea.
 F: \$30.00 ea.
 G: \$28.00 ea.
 H: \$26.00 ea.
 J: \$24.00 ea.

3 Inner Pole Diameter

- Multiply price by factor if Inner Pole is Pt/Ir. (SS is no extra charge.)
 B: x 1.25
 C, E, G, J, L: x 1.1
 D, F, H, K, M: x 1.0

4,5,6

Length (in millimeters)
 Add \$0.10 for every millimeter over 100

Note: Electrodes are sold in packages of 3. Prices are in US\$

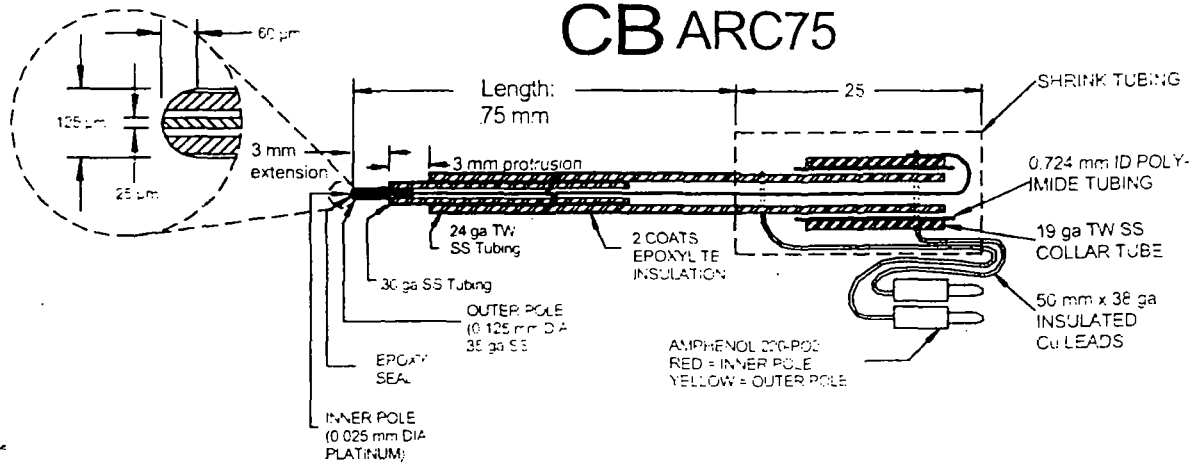

K3-78A; February 23, 2001



FHC Inc., 9 Main Street, Bowdoinham ME 04008 USA
 Telephone: 207-666-8190 • US & Canada: 800-326-2905 • FAX: 207-666-8292
 E-mail: fhcinc@fh-co.com • Website: http://www.fh-co.com/010300

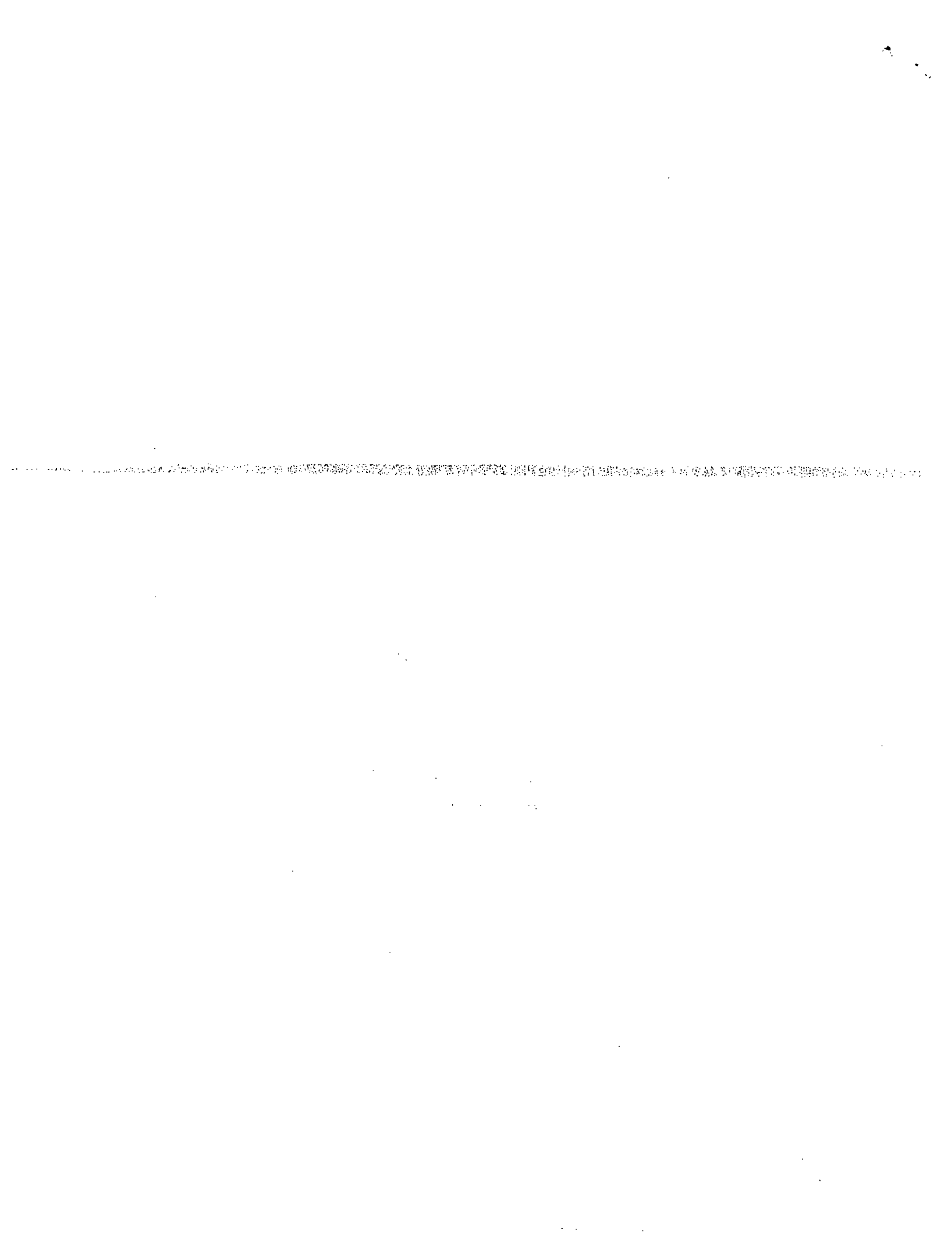

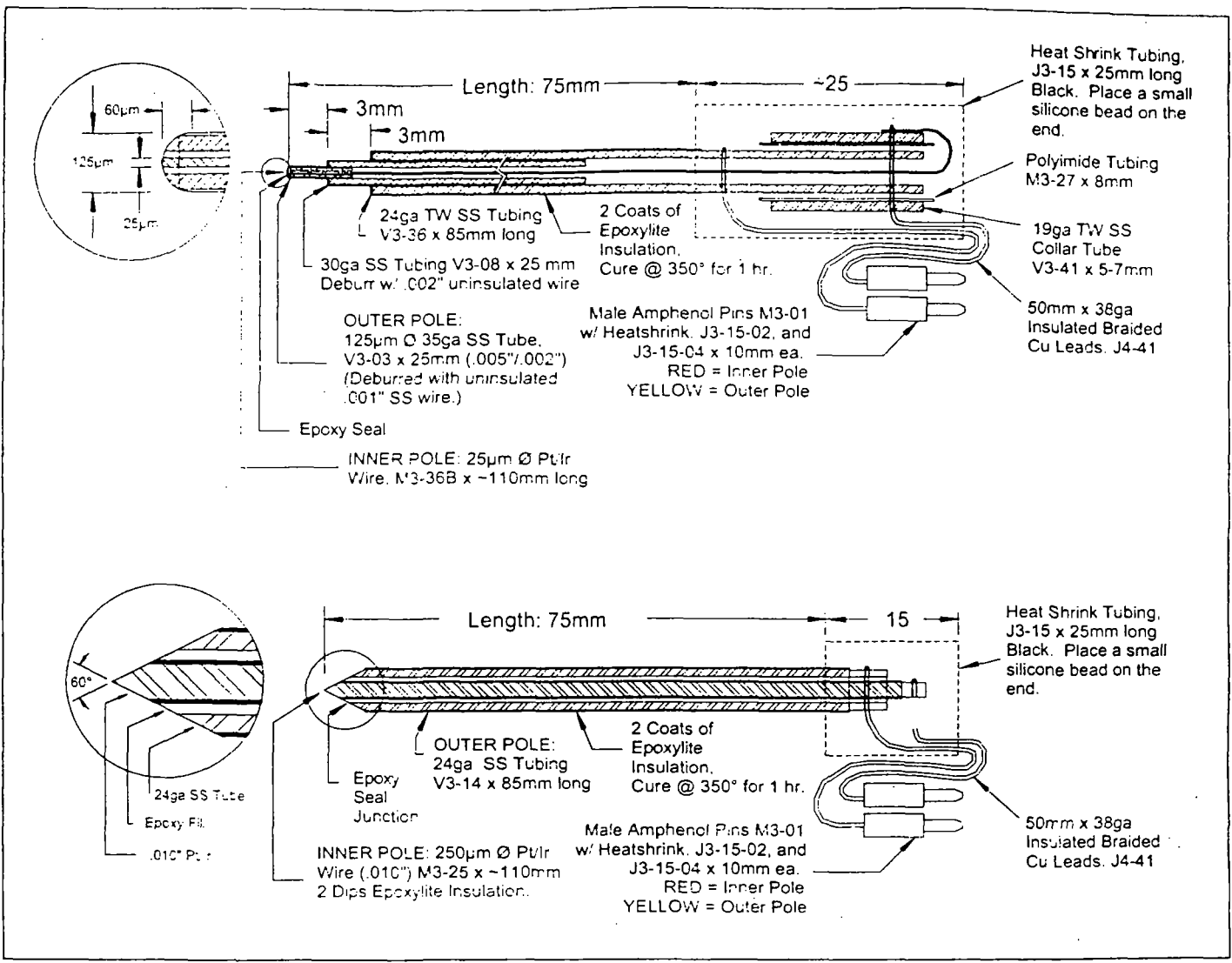

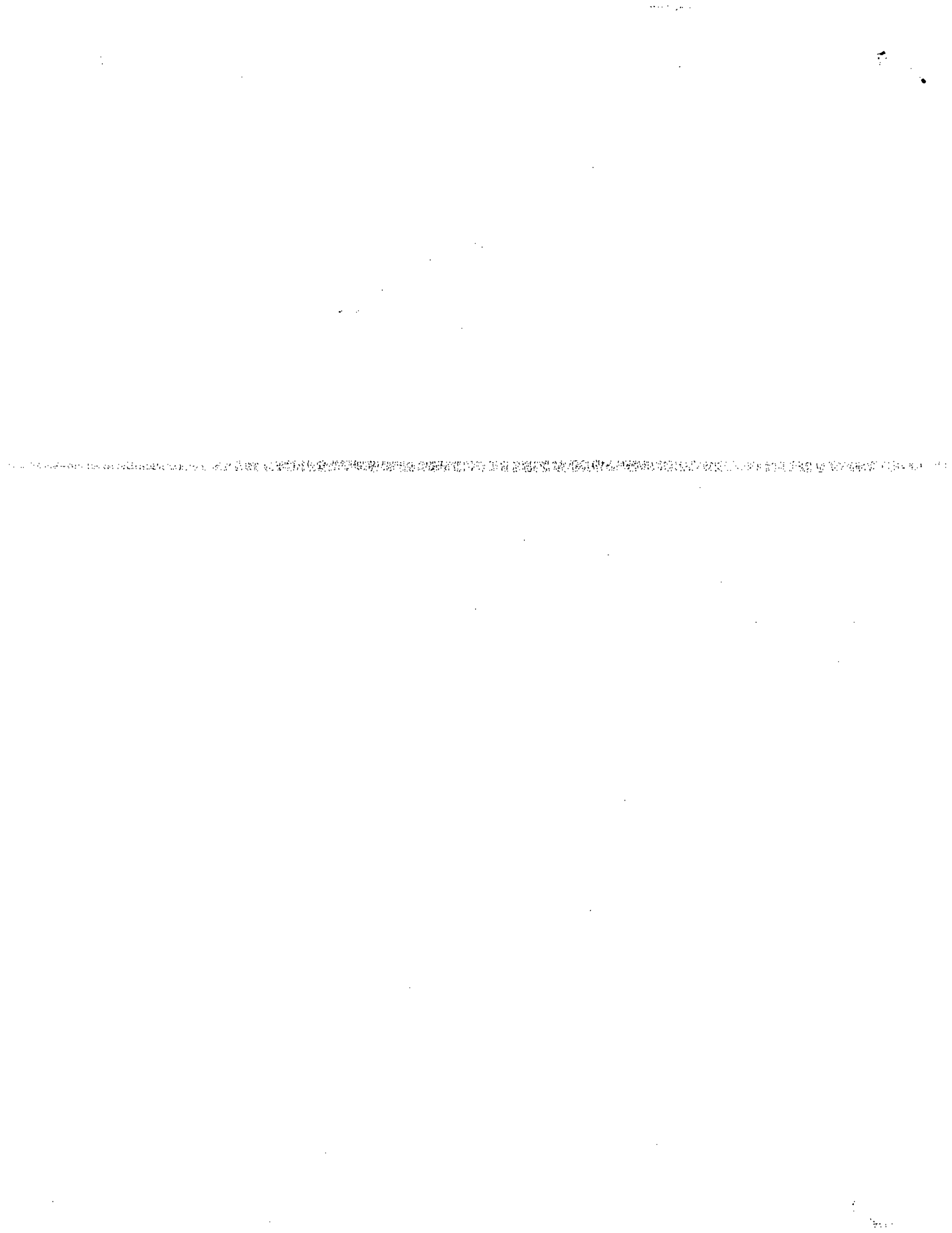

Macroelectrode Quality Inspection

(QS24-02)

Dear Customer,

These macroelectrodes have been made with pride and thoroughly checked for defects prior to shipment. All FHC Macroelectrodes are rinsed in alcohol immediately prior to packaging but should not be considered sterile. Our macroelectrodes are resilient to most common methods of sterilization (although the packaging may not be). As with any electrode, the tip is very fragile. If the packaging is in any way damaged when you receive these electrodes, please contact our customer service department for a timely resolution. FHC will gladly replace any macroelectrodes that you consider to be less than perfect.

With proper care and cleaning, FHC Macroelectrodes can usually be reused many times. FHC recommends holding the electrodes up to a water tap to rinse off any tissue or fluid deposits and/or soaking them in an ultrasonic cleaner with a mild detergent, then reesterilizing. With age and use, the exposed contacts on the electrode will oxidize. In extreme cases, gently scraping the tip of the electrode with a fine emery paper or polishing cloth can recondition the tips, although this is not possible with some configurations.

It is our sincerest hope that you will find FHC Macroelectrodes to be consistently of the highest quality. Please let us know if these macroelectrodes fall short of your expectations in any way. Your continuing satisfaction is important to us.

FHC, Inc. Frederick Haer & Co.
9 Main Street
Bowdoinham, ME 04008 USA

Phone: (207) 666-8190
Fax: (207) 666-8292
Email: fhcinc@fh-co.com
Web: www.fh-co.com

Inspected by: MD (MS) Date: 10/31/02

Work Order(s): 23698 Lot No.: 110809 Sales Order: 13931
23699 110836
23700 110837

Revision	Description	Edited by	Date
A	Originated	MAA	5-19-00
B	Added additional lines for WO'S	WBB	6-29-00

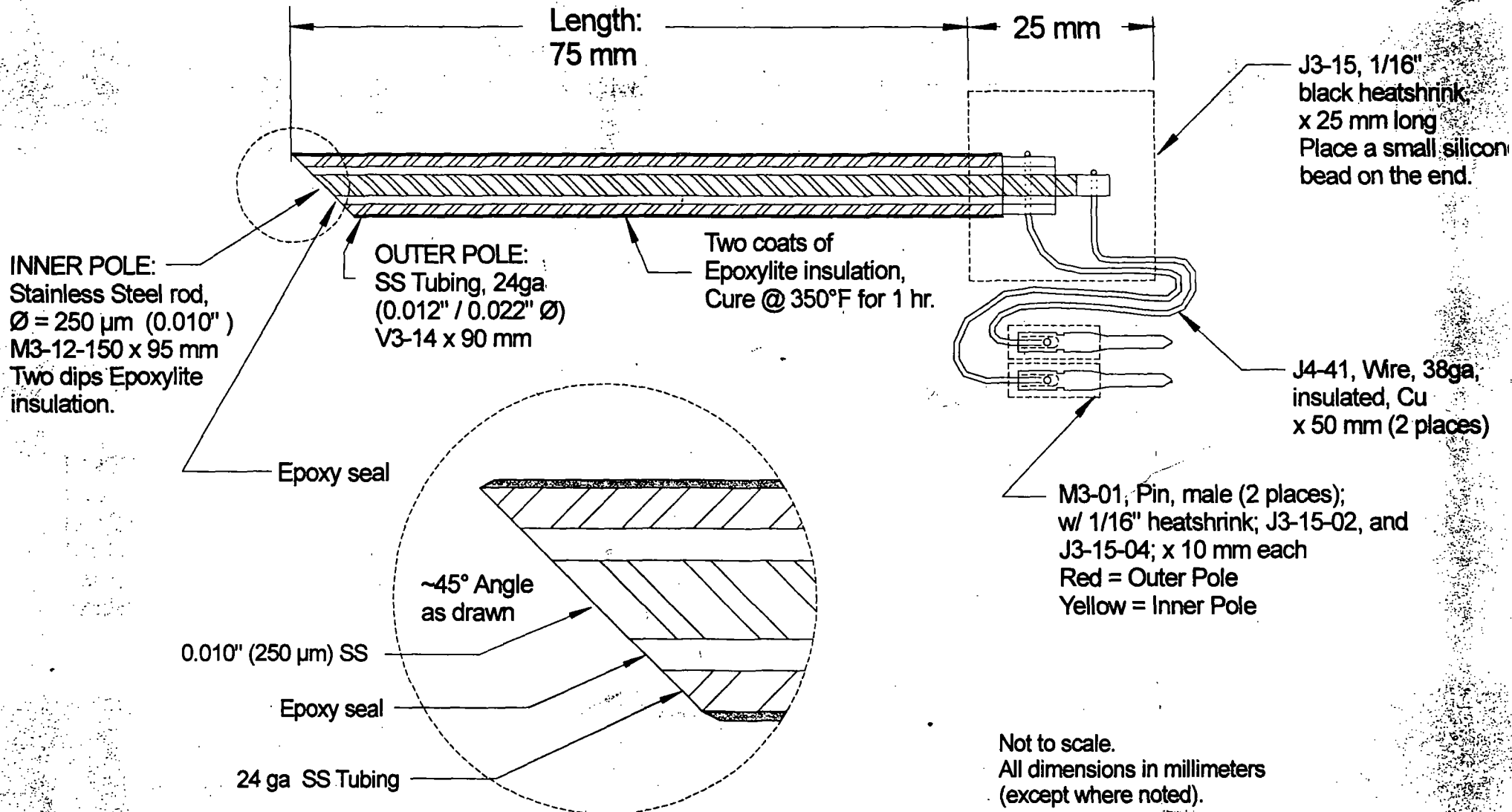

Not to scale.
All dimensions in millimeters (except where noted).

REV	Description	Date	Drwn	Appr
A	ORIGINATED, based on CBIBM75	10/01/02	WBB	<i>[Signature]</i>

FHC <small>NINE MAIN STREET BOWDOINHAM, ME 04008 USA TEL: (207) 686-8190 FAX: (207) 686-8282</small>	Inventory #: CBIBM75	WBB	10/01/02
	Concentric Bipolar Electrode	File: CBIBM75.cad	

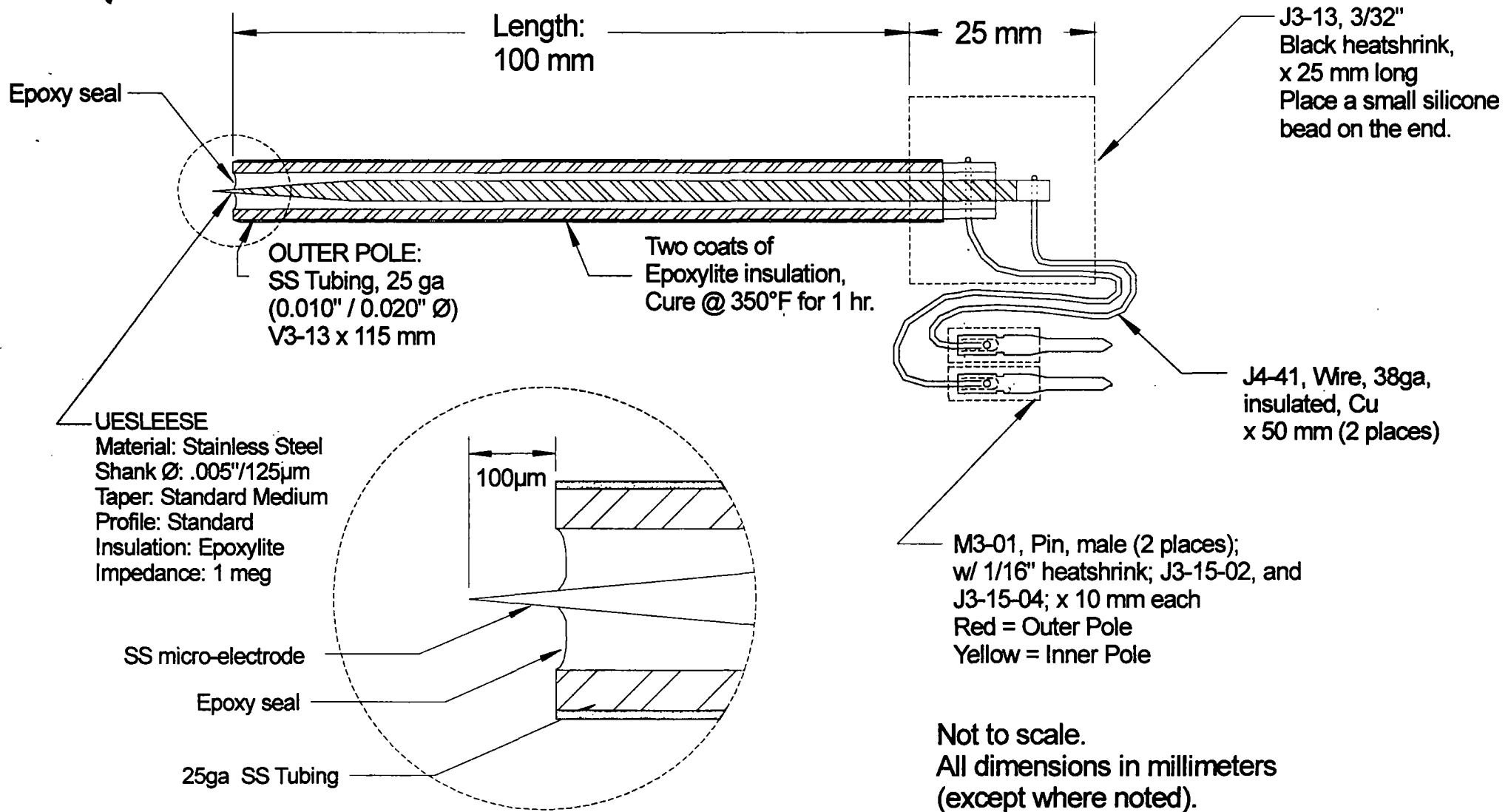

REV	Description	Date	Drwn	Appr
A	ORIGINATED, based on CBHMX75(MN1)	10/02/02	WEBB	<i>[Signature]</i>

FHC
NINE MAIN STREET
BOWDOINHAM, ME 04008 USA
TEL: (207) 698-8190
FAX: (207) 698-8292

Inventory #:
CBHMX100(DK1)
Concentric Bipolar
micro-electrode

Developed For
Dr. David Kleinfeld
File:
CBHMX100(DK1).cad

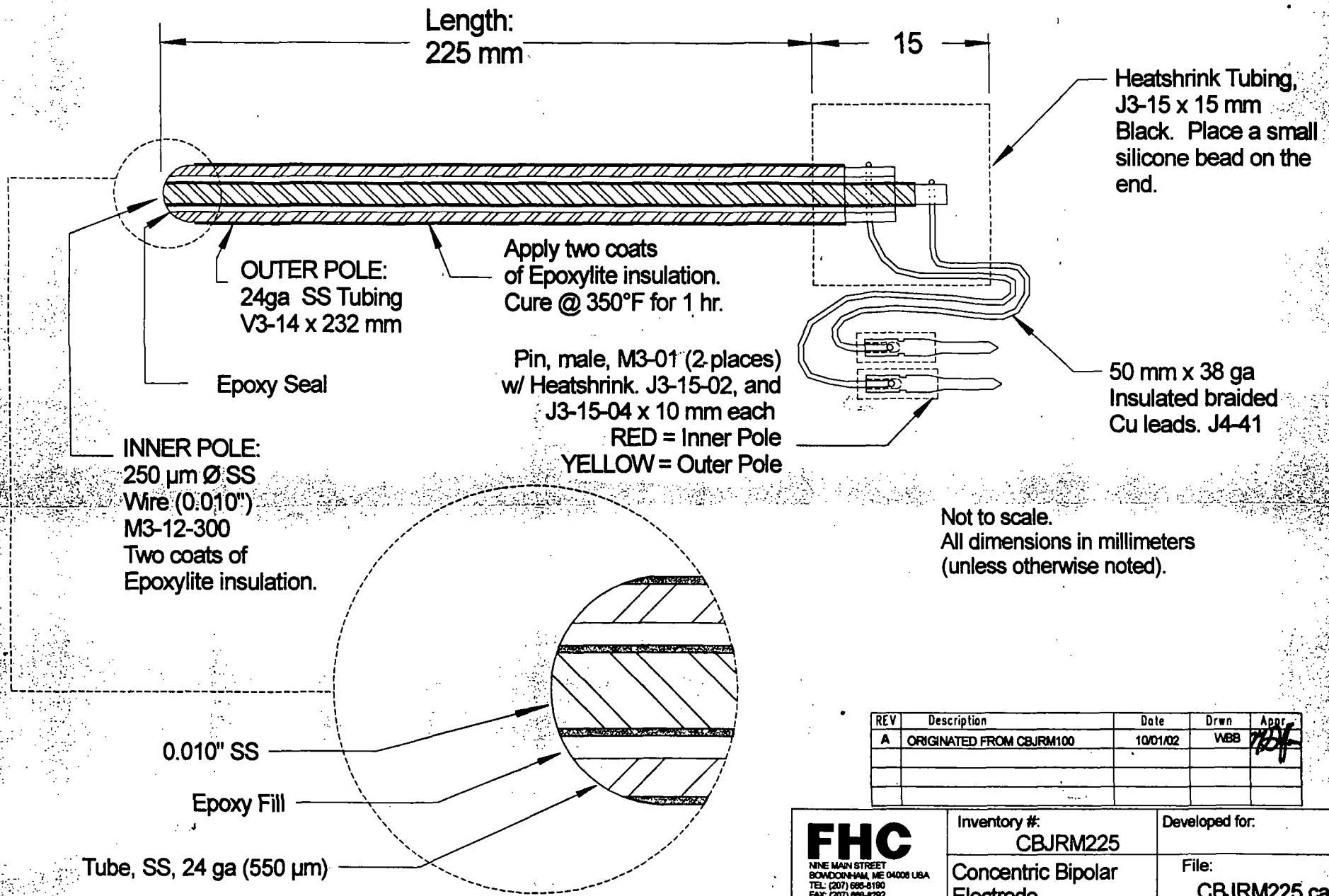

REV	Description	Date	Drwn	Appr
A	ORIGINATED FROM CBJRM100	10/01/02	WBB	<i>[Signature]</i>

FHC <small>NINE MAIN STREET BOWDOINHAM, ME 04008 USA TEL: (207) 686-8180 FAX: (207) 686-8292</small>	Inventory #: CBJRM225	Developed for:
	Concentric Bipolar Electrode	File: CBJRM225.cad