

CFT Series Recirculating Chiller

NESLAB Manual P/N 002167
Rev. 08/20/97

Instruction and Operation Manual



NESLAB online

Product Service Information, Electronic Catalog,
Applications Notes, MSDS Forms, e-mail.

(603)427-2490

Set modem to 8-N-1 protocol, 1200 - 14400 baud

Voice Info: (800) 4-NESLAB

Comments on this manual can be sent to:

NESLAB@lifesciences.com

or visit our Web page at:

<http://www.neslabinc.com>

CFT Series Recirculating Chiller

PREFACE

| | |
|--------------------------|---|
| Compliance | 3 |
| Unpacking | 3 |
| Warranty | 3 |
| After-sale Support | 3 |

SECTION I Safety

| | |
|---------------------------|---|
| Warnings | 4 |
| Additional Warnings | 5 |

SECTION II General Information

| | |
|------------------------|---|
| Description | 6 |
| Specifications | 6 |
| Cooling Capacity | 8 |
| Pump Capacity | 8 |

SECTION III Installation

| | |
|---|----|
| Site | 9 |
| Electrical Requirements | 10 |
| Plumbing Requirements | 10 |
| Fluids | 11 |
| Water Quality Standards and Recommendations | 12 |
| Filling Requirements | 14 |

SECTION IV Operation

| | |
|--|----|
| Start Up | 15 |
| Analog Temperature Controller | 15 |
| Digital Temperature Controller | 16 |
| Pressure Relief Valve | 16 |
| High Temperature Cutout (Optional) | 17 |
| CFT-300 High/Low Pressure Cutouts | 17 |
| CFT-150 High Pressure Cutout | 17 |
| Heater Package (Optional) | 18 |
| External Pressure Regulator (Optional) | 19 |

SECTION V Maintenance & Service

| | |
|--|----|
| Service Contracts | 20 |
| Draining the Reservoir | 20 |
| Cleaning | 20 |
| Algae | 21 |
| Pump Strainer | 21 |
| Pump Lubrication | 22 |
| Hoses | 22 |
| Suction Discharge Pressure/Speed Check | 22 |

SECTION VI Troubleshooting

| | |
|--------------------------|----|
| Checklist | 23 |
| Service Assistance | 23 |
| Pump Flow Diagram | 24 |

WARRANTY

CFT Series Quick Reference Operating Procedures

Installation

The unit has an air-cooled refrigeration system. Air is drawn in the front of the unit and discharged through rear and side. Position the unit so the intake and discharge are not impeded. Inadequate ventilation will cause a reduction in cooling capacity and, in extreme cases, compressor failure.

Excessively dusty areas should be avoided and a periodic cleaning schedule should be instituted. For proper operation, the unit needs to pull substantial amounts of air through a condenser. A build up of dust or debris on the fins of the condenser will lead to a loss of cooling capacity.

The unit will retain its full rated capacity in ambient temperatures up to approximately +24°C.

Make sure the voltage of the power source meets the specified voltage, $\pm 10\%$.

The plumbing connections are located on the rear of the unit and are labelled either SUPPLY and RETURN or OUTLET and INLET. These connections are $\frac{1}{2}$ inch FPT, $\frac{3}{4}$ inch FPT for CFT-300s. Remove the plastic protective plugs from both plumbing connections. Connect the OUTLET/SUPPLY fitting to the inlet of the instrument being cooled. Connect the INLET/RETURN fitting to the outlet of the instrument being cooled.

To fill the reservoir remove the reservoir access panel by unscrewing the thumbscrews. Locate the reservoir plug (square nut). Remove the plug and fill the reservoir with clean cooling fluid.

Tap water is the recommended fluid for operation from +8°C to +30°C. Below +8°C, a non-freezing fluid must be used. A mixture of tap water and laboratory grade ethylene glycol is suggested.

Operation

Before starting the unit, double check all electrical and plumbing connections. Make sure the circulating system has been filled with cooling fluid.

To start the unit, place the Power Switch to the on position. The Power Switch illuminates (except for the CFT-150) to indicate the system is operating. To turn the unit off, place the Power Switch to the off position.

The Cool LED indicates the status of the refrigeration system. It illuminates to indicate the refrigeration system is removing heat from the cooling fluid. As the operating temperature approaches the setpoint, the LED will extinguish.

When the unit is shut off, wait approximately five minutes before restarting. This allows time for the refrigeration pressures to equalize. If the pressures are not allowed to equalize, the compressor will short-cycle and no cooling will occur.

Analog Controller Temperature Adjustment

To adjust the temperature setpoint, turn the °C dial on the front of the unit to the desired temperature.

Digital Controller Temperature Adjustment

To display the temperature setpoint, press and hold the DISPLAY switch. To adjust the temperature setpoint, press and hold the DISPLAY switch and turn the ADJUST knob until the desired temperature setpoint is indicated on the digital display. Once the setpoint is adjusted, release the DISPLAY switch. The display will now indicate the temperature of the fluid in the reservoir.

Periodic Maintenance

Periodically inspect the reservoir fluid. If cleaning is necessary, flush the reservoir with a cleaning fluid compatible with the circulating system and the cooling fluid.

The cooling fluid should be replaced periodically. When operating at low temperatures, the concentration of water in the cooling fluid will increase over time, leading to a loss of cooling capacity.

Before changing the cooling fluid, raise the unit's operating temperature to de-ice the cooling coils.

Periodic vacuuming of the condenser fins is necessary. The frequency of cleaning depends on the operating environment. We recommend a visual inspection of the condenser be made monthly after initial installation. After several months, the cleaning frequency will be established.

Units with PD pumps have a strainer. If debris is in the system, the strainer will prevent the material from being drawn into the pump and damaging the pump vanes.

After initial installation, the strainer may become clogged. The strainer must be cleaned after the first week of installation. After this first cleaning, a monthly visual inspection is recommended. After several months, the frequency of cleaning will be established. Before cleaning, disconnect the power cord from the power source and drain the reservoir.

Preface

Compliance

Products tested and found to be in compliance with the requirements defined in the EMC standards defined by 89/336/EEC as well as Low Voltage Directive (LVD) 73/23/EEC can be identified by the CE label on the rear of the unit. The testing has demonstrated compliance with the following directives:

| | |
|-----------------|--------------------------------|
| LVD, 73/23/EEC | Complies with UL 3101-1:93 |
| EMC, 89/336/EEC | EN 55011, Class A Verification |
| | EN 50082-1:1992 |
| | IEC 1000-4-2:1995 |
| | IEC 1000-4-3:1994 |
| | IEC 1000-4-4:1995 |

For any additional information refer to the Letter of Compliance that shipped with the unit (Declaration of Conformity).

Unpacking

Retain all cartons and packing material until the unit is operated and found to be in good condition. If the unit shows external or internal damage, or does not operate properly, contact the transportation company and file a damage claim. Under ICC regulations, this is your responsibility.

If this product has been modified to operate at 0°C or lower, it has been tested with a non-freezing fluid. Although the system has been drained, some residual fluid may remain. This will not hinder your unit's performance.

Warranty

Units have a warranty against defective parts and workmanship for one full year from date of shipment. See back page for more details.

After-sale Support

NESLAB is committed to customer service both during and after the sale. If you have questions concerning the unit operation, contact our Sales Department. If your unit fails to operate properly, or if you have questions concerning spare parts or Service Contracts, contact our Service Department.

Before calling, please refer to the labels on the rear of the unit to obtain the following information:

- *unit BOM number* _____

- *unit serial number* _____

- *pump type* _____

Section I Safety

Warnings



Warnings are posted throughout the manual. These warnings are designated by an exclamation mark inside an equilateral triangle and text highlighted in bold. Read and follow these important instructions. Failure to observe these instructions can result in permanent damage to the unit, significant property damage, or personal injury or death.

Make sure you read and understand all instructions and safety precautions listed in this manual before installing or operating your unit. If you have any questions concerning the operation of your unit or the information in this manual, please contact our Sales Department (see After-sale Support).

Never place the unit in a location where excessive heat, moisture, or corrosive materials are present.

The unit construction provides extra protection against the risk of electrical shock by grounding appropriate metal parts. The extra protection may not function unless the power cord is connected to a properly grounded outlet. It is the user's responsibility to assure a proper ground connection is provided.

Never connect the OUTLET/SUPPLY or INLET/RETURN fitting to your building water supply or any water pressure source.

Never use flammable or corrosive fluids with this unit. Distilled and deionized water may be aggressive and cause material corrosion. Please contact NESLAB before subjecting this unit to prolonged exposure to distilled or deionized water.

Do not use automobile anti-freeze. Commercial anti-freeze contains silicates that can damage the pump seals. Use of automobile anti-freeze will void the manufacturer's warranty.

Do not replace reservoir plug with a non-vented type or damage to the tank may occur.

For personal safety and equipment reliability, the following procedure should only be performed by a competent technician. Contact our Service Department for assistance (see Preface, After-sale Support).

Additional Warnings

In addition to the specific warnings listed on the previous page the following general warnings apply to you unit:

Performance of installation, operation, or maintenance procedures other than those described in this manual may result in a hazardous situation and may void the manufacturer's warranty.

Transport the unit with care. Sudden jolts or drops can damage the refrigeration lines.

Observe all warning labels.

Never remove warning labels.

Never operate damaged or leaking equipment.

Never operate the unit without cooling fluid in the reservoir.

Always turn off the unit and disconnect the power cord from the power source before performing any service or maintenance procedures, or before moving the unit.

Always empty the reservoir before moving the unit.

Never operate equipment with damaged power cords.

Refer service and repairs to a qualified technician.

Section II General Information

Description

The CFT Recirculating Chiller is designed to provide a continuous supply of cooling fluid at a constant temperature and volume.

The unit consists of an air-cooled refrigeration system, a sealable reservoir, recirculating pump, and a temperature controller.

Throughout the manual, you will be asked to consult the unit's serial number label or the pump identification label for specific information. Both labels are located on the rear of the unit.

Specifications

| | CFT-25 | CFT-33 | CFT-75 | CFT-150 | CFT-300 | |
|--|---------------|-----------|------------|---------------|------------|-------------------------------|
| Cooling Capacity¹ | | | | | | |
| | 60Hz | 580 Watts | 950 Watts | 2100 Watts | 4500Watts | 10650 Watts |
| | 50Hz | 475 Watts | 1000 Watts | 1900 Watts | 3735 Watts | 9000 Watts |
| Temperature Range | +5°C to +30°C | | | +5°C to +35°C | | |
| Temperature Stability^{2,3} | ±1.0°C | | | | | |
| | | | | | | Analog Temperature Controller |
| Digital Temperature Controller | ±0.5° | | | | ±1.0° | |
| Reservoir Volume | | | | | | |
| | | | | | | Gallons |
| Liters | 1.9 | 4.1 | 6.8 | 21.3 | | |
| Refrigerant | R134a | | | R22 | | |

1. Circulating water at 20°C, at 20°C ambient. Cooling capacity will vary depending on fluid temperature, ambient temperature, and cooling fluid. A PD-1 pump was used in the CFT-25, a PD-2 in the other units.
2. Stability determined for CFT-150 analog unit with 75% heat load @ 20°C circulating temperature.
3. CFT-300 stability determined with 86% heat load.

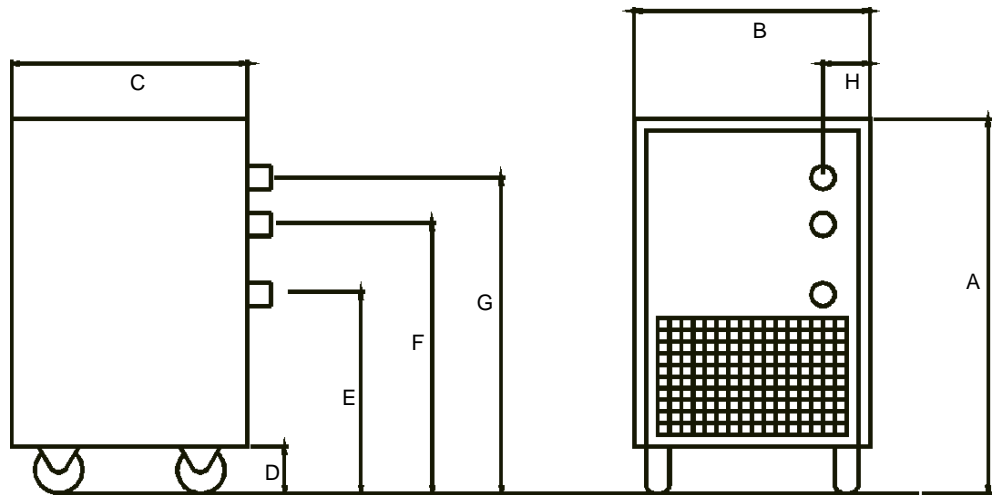

| | CFT25 | CFT33 | CFT75 | CFT150 | CFT300 |
|---------------------------------|------------------|------------------|-------------------|-------------------|-----------------|
| Unit Dimensions | | | | | |
| <i>Dimension A</i> | 22 | 24½ | 26½ | 36¾ | 43 |
| <i>Dimension B</i> | 12½ | 14¾ | 14 7/8 | 21¾ | 25½ |
| <i>Dimension C</i> | 21 | 22 | 24½ | 27¾ | 28½ |
| <i>Dimension D</i> | 2¾ | 2½ | 2½ | 3½ | 2¾ |
| <i>Dimension E</i> | NA | NA | NA | NA | 29 |
| <i>Dimension F</i> | 17 1/16 | 18½ | 22 | 32¼ | 38¼ |
| <i>Dimension G</i> | 20 1/16 | 21½ | 25 | 35¼ | 41¼ |
| <i>Dimension H</i> | 1½ | 1 | 1 1/8 | 1 1/8 | 1 |
| Crate Dimensions (H x W x D) | 31x23x28 | 31x23x32 | 32x23x40 | 33x29x42 | 35x33x56 |
| Shipping Weight | 110 | 161 | 181 | 320 | 450 |
| Air Intake | 280 | 375 | 800 | 1050 | 2500 |
| Electrical Requirements | | | | | |
| <i>Volts</i> | 115V | 115V | 208/230V | 208/2300V | 208/230V |
| <i>Hertz</i> | 60Hz | 60Hz | 60Hz | 60Hz | 60Hz |
| <i>Phase</i> | 1 | 1 | 1 | 1 | 3 |
| <i>Plug</i> | NEMA5-15P | NEMA5-20P | NEMAL6-15P | NEMAL6-20P | NA |

1. Dimension A is the height of the unit. The unit width and depth (dimensions B and C) are the case dimensions. Add approximately 2 inches to include the plumbing connections.
2. Dimension D is the distance from the floor to the bottom of the unit case (height of the castors).
3. Dimension E is the distance from the floor to the center of the DRAIN connection (CFT-300 only).
4. Dimension F is the distance from the floor of the center of the OUTLET connection.
5. Dimension G is the distance from the floor of the center of the INLET connection.
6. Dimension H is the distance from the unit's left side to the center of the INLET, OUTLET and DRAIN connections.
7. Weights are given in pounds
8. Air intake is given in cubic feet per minute.

Pump Capacity¹

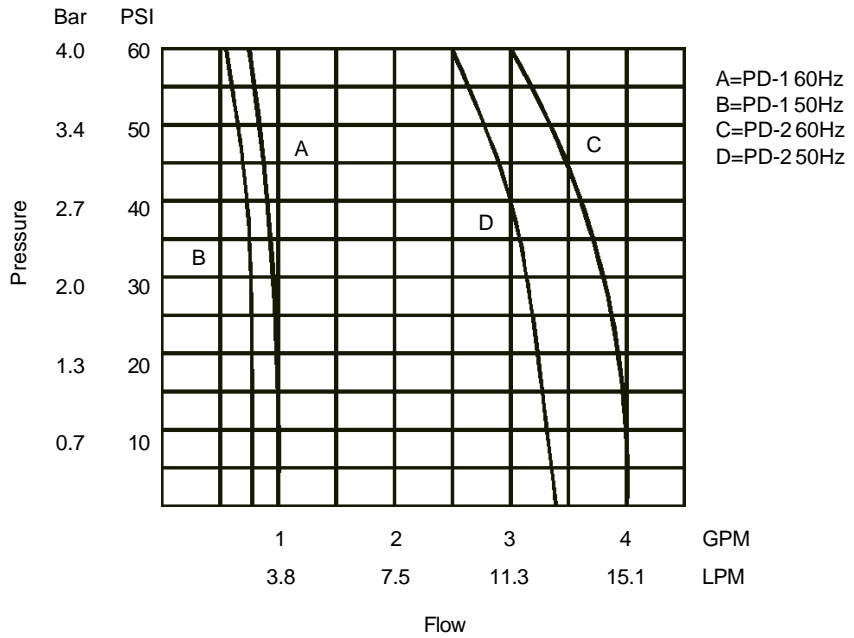
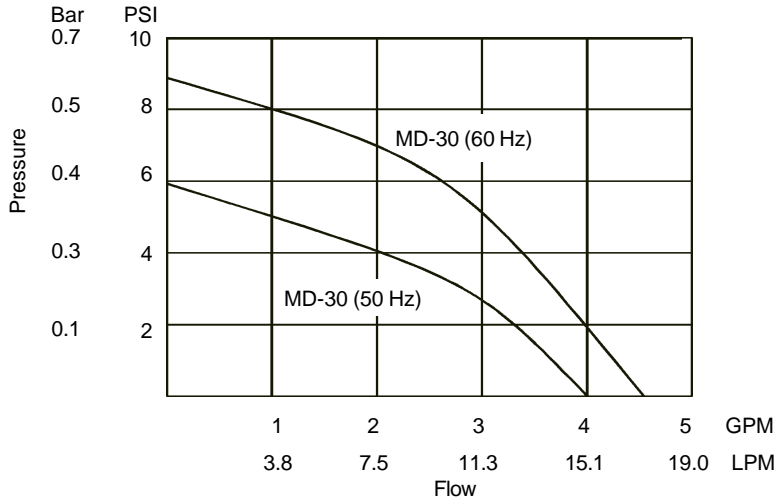

1. To determine which pump is installed, refer to the label on the rear of your unit.

Section III Installation

Site

The unit should be located in a laboratory or clean industrial environment where ambient temperatures are inside the range of +13°C to +35°C.



Never place the unit in a location where excessive heat, moisture, or corrosive materials are present.

The unit has an air-cooled refrigeration system. Air is drawn through the front of the unit and discharged through rear and side panels. The unit must be positioned so the intake and discharge are not impeded. A minimum clearance of 18 inches (45 centimeters) on all vented sides is necessary for adequate ventilation. Inadequate ventilation will cause a reduction in cooling capacity and, in extreme cases, compressor failure.

Excessively dusty areas should be avoided and a periodic cleaning schedule should be instituted (see Section V, Cleaning).

The unit will retain its full rated capacity in ambient temperatures up to approximately +24°C. Above +24°C, derate the cooling capacity 1% for every 0.5°C above +24°C, up to a maximum ambient temperature of +35°C.

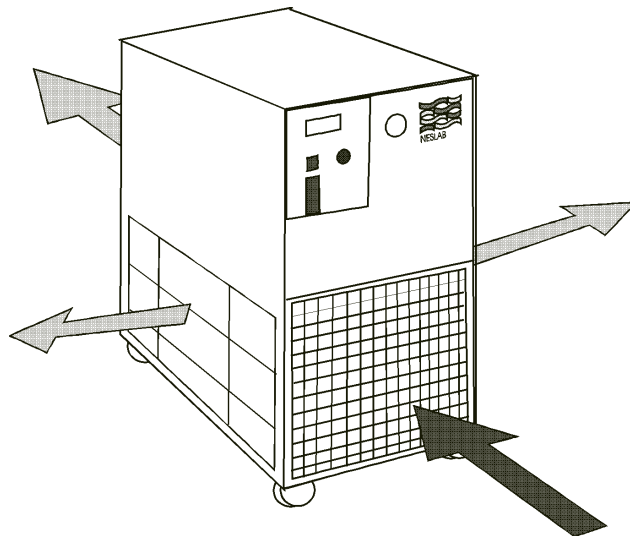

Direction of Air Flow

Electrical Requirements



The unit construction provides extra protection against the risk of electrical shock by grounding appropriate metal parts. The extra protection may not function unless the power cord is connected to a properly grounded outlet. It is the user's responsibility to assure a proper ground connection is provided.

Refer to Section II, Specifications, and to the serial number label on the rear of the unit for the specific electrical requirements of your unit.

The CFT-300 is supplied with a disconnect box. Wire the power connections in accordance to local, state and federal electrical codes. Double check all wiring to make sure it is properly connected and protected from the elements.

The CFT-300 is also equipped with a compressor crankcase heater. The crankcase heater warms the oil in the compressor and prevents refrigerant from mixing with the oil. Before start up, the unit must be connected to its power source for at least 12 hours. This allows time for the oil to be heated and separate from the refrigerant.

Plumbing Requirements

Before installing the unit to an instrument that previously used tap water as a cooling fluid, flush the instrument several times to remove any rust or scale that has built up. The manufacturer of the instrument should be able to recommend a cleaning fluid for their equipment.

The plumbing connections are located on the rear of the unit and are labelled OUTLET/SUPPLY and INLET/RETURN. CFT-25 to CFT-150 connections are ½ inch FPT, CFT-150s with CP-55 pumps are ¾ inch and CFT-300 connections are ¾ inch FPT.

Remove the plastic protective plugs from both plumbing connections.

Connect the OUTLET/SUPPLY fitting to the inlet of the instrument being cooled. Connect the INLET/RETURN fitting to the outlet of the instrument being cooled.



Never connect the fittings to your building water supply or any water pressure source.

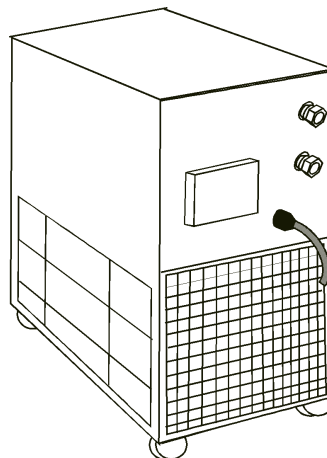

Plumbing Connections
(Typical)

Two sets of plumbing adapters are included with CFT-25 to CFT-150 units. One set of adapters will accept $\frac{3}{8}$ inch ID tubing. The other set will accept $\frac{1}{2}$ inch ID tubing. If the unit is being plumbed using flexible tubing, install one set of adapters in the plumbing ports. To prevent leaking, be sure to wrap the threads of the adapters with Teflon® sealing tape before installing them in the plumbing ports.

Flexible tubing, if used, should be of heavy wall or reinforced construction. All tubing should be rated to withstand 80 psig at +30°C. Make sure all tubing connections are securely clamped. Avoid running tubing near radiators, hot water pipes, etc. If substantial lengths of tubing are necessary, insulation may be required to prevent loss of cooling capacity.

Tubing and insulation are available from NESLAB. Contact our Sales Department for more information (see Preface, After-sale Support).

It is important to keep the distance between the unit and the instrument being cooled as short as possible, and to use the largest diameter tubing practical. Tubing should be straight and without bends. If diameter reductions must be made, they should be made at the inlet and outlet of the instrument being cooled, not at the CFT.

If substantial lengths of cooling lines are required, they should be pre-filled with cooling fluid before connecting them to the unit.

Fluids

The selected fluid must have a viscosity of 50 centistokes or less at the lowest operating temperature.



Never use flammable or corrosive fluids with this unit. Distilled and deionized water may be aggressive and cause material corrosion. Please contact NESLAB before subjecting this unit to prolonged exposure to distilled or deionized water.

Tap water is the recommended fluid for operation from +8°C to +30°C. See Water Quality Standards and Recommendations on the next page.

Below +8°C, a non-freezing fluid must be used. A mixture of tap water and laboratory grade ethylene glycol is suggested.



Do not use automobile anti-freeze. Commercial anti-freeze contains silicates that can damage the pump seals. Use of automobile anti-freeze will void the manufacturer's warranty.

Water Quality Standards and Recommendations

| | Permissible(PPM) | Desirable(PPM) |
|----------------------------------|------------------|----------------|
| Microbiologicals | | |
| (algae,bacteria,funghi) | 0 | 0 |
| Inorganic Chemicals | | |
| Calcium | <40 | 0.6 |
| Chloride | 250 | <25 |
| Copper | 1.3 | 1.0 |
| Iron | 0.3 | <0.1 |
| Lead | 0.015 | 0 |
| Magnesium | <12 | 0.1 |
| Manganese | 0.05 | <0.03 |
| Nitrates\Nitrites | 10 as N | 0 |
| Potassium | <20 | 0.3 |
| Silicate | 25 | <1.0 |
| Sodium | <20 | 0.3 |
| Sulfate | 250 | <50 |
| Hardness | 17 | <0.05 |
| Total Dissolved Solids | 50 | 10 |
| Other Parameters | | |
| pH | 6.5-8.5 | 7-8 |
| Resistivity | 0.01* | 0.05-0.1* |
| * Megohm-Cm (Compensated at 25C) | | |

Unfavorably high total ionized solids (TIS) can accelerate the rate of galvanic corrosion. These contaminants can function as electrolytes which increase the potential for galvanic cell corrosion and lead to localized corrosion such as pitting which can be observed at the studs and on the outside surface of cooling coils. Eventually, the pitting will become so extensive that the coil will leak refrigerant into the water reservoir.

As an example, raw water in the United States averages 171 ppm (as NaCl). The recommended level for use in a water system is between 0.5 to 5.0 ppm (as NaCl).

Recommendation: Initially fill the tank with distilled/deionized water. Do not use untreated tap water as the total ionized solids level may be too high.

Maintain this water quality at a resistivity of between 1 to 10 megohm-cm (compensated at 25°C) by using a purification system. Although the initial fill may be as high as 10 megohm-cm (compensated at 25°C), the desired level for long time usage is 1 to 3 megohm-cm (compensated at 25°C).

The above two recommendations will reduce the electrolytic potential of the water and prevent or reduce the galvanic corrosion observed.

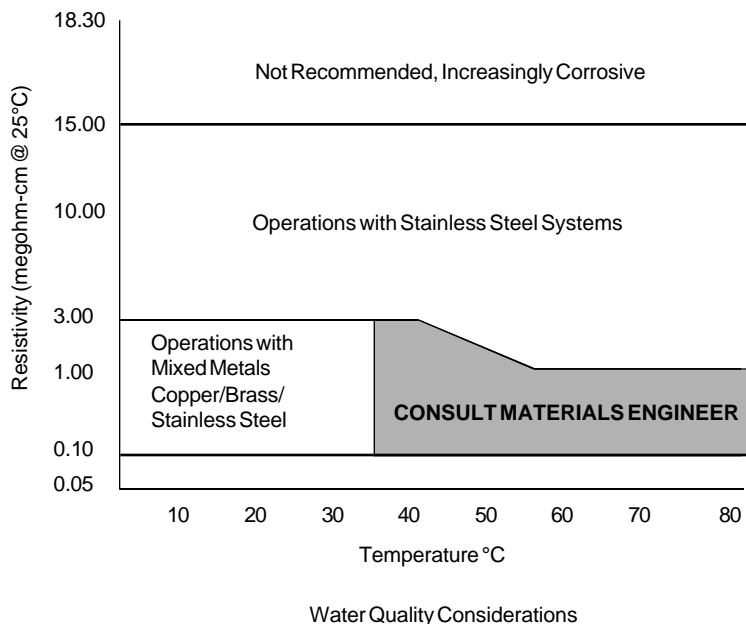

Filling Requirements

Remove the reservoir access panel by unscrewing the thumbscrews. Locate the reservoir plug (square nut). Remove the plug and fill the reservoir with clean cooling fluid, following the special considerations outlined in the following paragraphs.

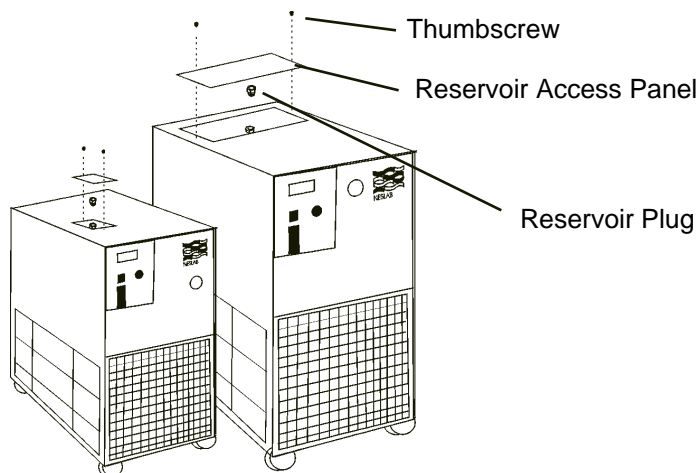

Reservoir filling locations (Typical)

NOTE: The CFT-300 has a FILL lamp which illuminates whenever the reservoir level is below normal operating level.

Circulating to a closed system (closed to the atmosphere)

Fill the reservoir to the bottom of the fill hole threads. Since the reservoir capacity is small compared to many instruments being cooled, have extra cooling fluid on hand to keep the system topped off when external circulation is started.

NOTE: The tank in your unit has a vent which relieves pressure built up from thermal expansion of water. The vent is located on the reservoir plug. It activates when tank pressure reaches 3 - 5 psi.



Do not replace reservoir plug with a non-vented type or damage to the tank may occur.

Circulating to an open system (open to the atmosphere)

Fill the reservoir so $\frac{3}{4}$ of the fill hole threads are covered. Wrap the tank plug with Teflon® sealing tape. Replace the tank plug and tighten securely to prevent air entry.

When circulating cooling fluid to an open vessel or tank, connect the OUTLET/SUPPLY and INLET/RETURN lines to the open tank. Secure the INLET/RETURN (suction) line below the fluid surface. The INLET/RETURN line should be submerged deep enough to avoid sucking air. Make sure the INLET/RETURN line is free of particles and debris that can block the flow of fluid. A baffle or screen may be required.

Section IV Operation

Start Up

Before starting the unit, double check all electrical and plumbing connections and make sure the circulating system (the CFT, the instrument being cooled, and the tubing that connects them) has been properly filled with cooling fluid. To start the unit, place the POWER Switch to the on (**I**) position. The refrigeration system and the recirculation pump will start. The POWER Switch illuminates (except for the CFT-150) to indicate the system is operating. Units with PD pumps display the pump operating pressure on the RECIRCULATING PRESSURE gauge.

To turn the unit off, place the POWER Switch to the off (**0**) position.

The Cool LED on the front panel indicate the status of the refrigeration system. It illuminates to indicate the refrigeration system is removing heat from the cooling fluid. As the operating temperature approaches the temperature setpoint, the LED will extinguish.

The Idle LED on the front panel of CFT-150 units indicates the unit is in a hot-gas-bypass mode of operation. As the operating temperature approaches the temperature setpoint, the Cool and Idle LEDs cycle to indicate the approximate duty cycle of the unit.

When the unit is shut off, wait approximately five minutes before restarting. This allows time for the refrigeration pressures to equalize. If the pressures are not allowed to equalize, the compressor will short-cycle (clicking sound) and no cooling will occur.

Analog Temperature Controller

Temperature Adjustment

To adjust the temperature setpoint, turn the calibrated °C dial on the front of the unit to the desired temperature.

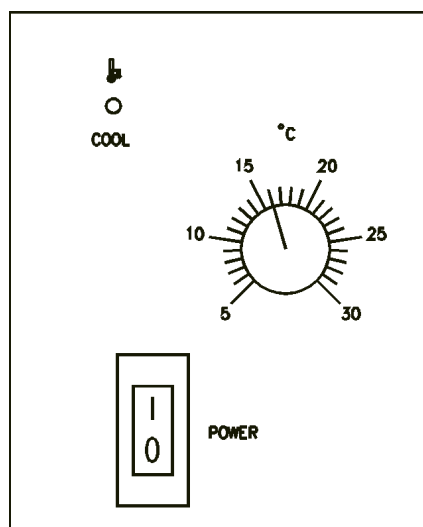

Analog Temperature Controller (Typical)

Digital Temperature Controller

Temperature Adjustment

To display the temperature setpoint, press and hold the DISPLAY switch. To adjust the temperature setpoint, press and hold the DISPLAY switch and turn the ADJUST knob until the desired temperature setpoint is indicated on the digital display. Once the setpoint is adjusted, release the DISPLAY switch. The display will now indicate the temperature of the fluid in the reservoir.

NOTE: Inadvertent movement of the ADJUST knob, regardless of the position of the DISPLAY switch, will result in a change in the setpoint. This change will not be immediately reflected on the digital display, unless the DISPLAY switch is pressed. The digital display will eventually change as the unit reacts to the new setpoint.

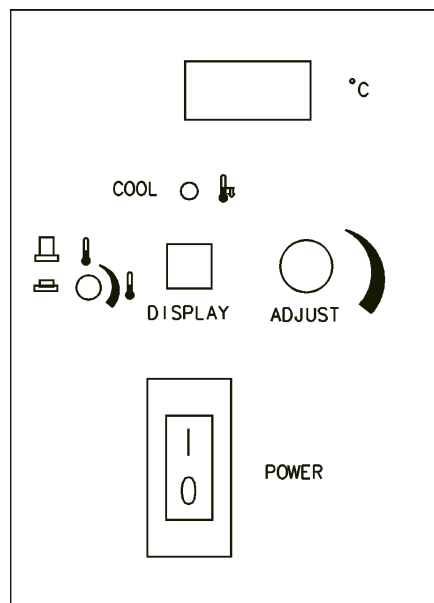

Digital Temperature Controller (Typical)

Pressure Relief Valve

Units with PD pumps have a pressure relief valve which establishes the maximum operating pressure of the unit. If the pressure of the fluid leaving the pump exceeds the valve setting, the relief valve will bypass the fluid within the unit to relieve the pressure. The relief valve does not determine the actual operating pressure; the operating pressure is determined by the back pressure of the system.

If an adjustment is necessary, contact our Customer Service Department.

High Temperature Cutout (Optional)

The High Temperature Cutout (HTC) is designed to shut down the unit in the event the temperature of the fluid in the reservoir exceeds the HTC setting. The HTC is normally located on the rear of the unit.

NOTE: The HTC temperature scale is in °F.

CFT-300 High/Low Pressure Cutout

CFT-300 units are equipped with high and low refrigeration pressure cutouts. Should either cutout activate the unit will shut down.

The High Pressure Cutout (HPC) activates if there is a blockage in the refrigeration lines or if the refrigerant temperature becomes too hot. The HPC is factory preset at 400psi.

The Low Pressure Cutout (LPC) activates if there is a leak in the refrigeration lines. THE LPC is factory preset at 4psi.

Both cutouts are located inside the case behind the rear panel. Once the cause of the shut down has been determined and corrected, manually depress the white button on the applicable cutout. If a "click" is not heard when depressing the button, the cutout was not activated and the unit shut down for another reason.

CFT-150 High Pressure Cutout

Some CFT-150 units are equipped with High Pressure Cutouts (HPC). Should the HPC activate the unit will shut down.

The HPC activates if there is a blockage in the refrigeration lines or if the refrigerant temperature becomes too hot. The HPC is factory preset at 400psi.

The cutout is located inside the case behind the rear panel. Once the cause of the shut down has been determined and corrected, manually depress the white button on the applicable cutout. If a "click" is not heard when depressing the button, the cutout was not activated and the unit shut down for another reason.

Heater Package (Optional)

Heaters are controlled by a switch on the temperature controller. The heater itself is accessible through the small service panel on the rear of the unit.

These units also have a Low Level indicator. The indicator illuminates if the fluid level in the reservoir drops below proper operating level.

Illustration A shows the desired fluid level for normal operation.

Should the reservoir be filled as shown in illustration B, units designed to operate at high-end temperatures (near boiling) may cause air in the reservoir to become trapped. The air can be vented by slightly tilting the unit forward on its front castors.

Any fluid venting from the reservoir will drain through a hose which feeds to a small hole in the bottom of the unit.



Do not use silicon-based fluids with units designed to operate at high temperatures. These type fluids will damage the hoses and pump seal.

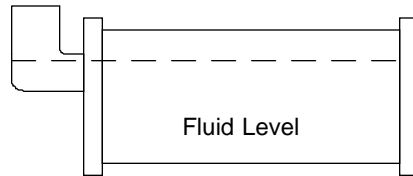

Illustration A

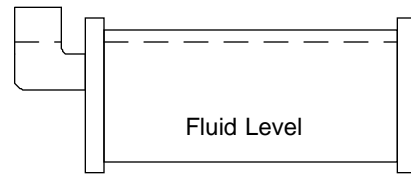

Illustration B

External Pressure Regulator (Optional)

For applications requiring a maximum pressure less than 55 PSI (380 kPa), an External Pressure Reducer (EPR) is available. An EPR allows an adjustable operating pressure of 10 to 50 PSI (70 to 345 kPa). If the pressure of the fluid leaving the chiller exceeds the relief valve setting, the relief valve will bypass excess fluid back into the chiller to relieve the overpressure.

The pressure of the system is determined by the back pressure of the connected equipment and the flow rate of the recirculating fluid to your application. Connect the EPR as described.

NOTE: Install the fittings in the exact sequence shown.

NOTE: Use Teflon® tape on all threaded fittings.

Connect the Inlet Tee Assembly (1) to the chiller. Connect the Outlet Tee Assembly (2) to the chiller. Attach the relief valve (3) to the Outlet Tee Assembly (2). Attach the Hose Nipple (4) to the Relief Valve (3). Attach the Hose (5) between the Inlet Tee Assembly (1) and the Hose Nipple (4).

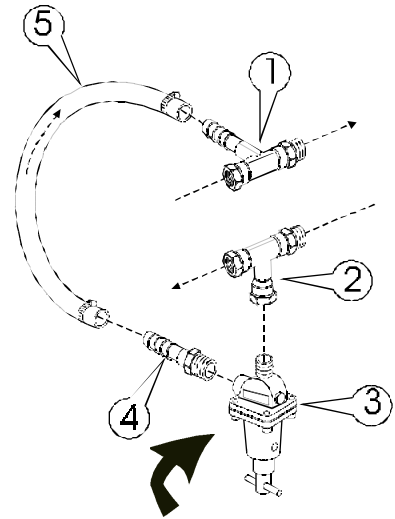

The EPR is now installed. Connect the inlet (to your application) to the remaining fitting of the Outlet Tee Assembly (2). Connect the outlet (from your application) to the remaining fitting of the Inlet Tee Assembly (1).

Tighten the hose clamps tight enough to prevent leakage. Do not overtighten or the clamps will bite into the flexible tubing and cause excessive wear. If a torque wrench is available, torque hose clamps to 50 in/lbs (280 cm/kg). Nylon-reinforced hose tends to cold-flow, so the clamps will need to retorqued later. (The hose clamps do not actually loosen, but rather the hose outside diameter decreases!).

The "T" adjustment handle is equipped with a locknut. To adjust the relief pressure setting loosen the locknut and turn the "T" handle to the minimum pressure setting (direction of arrow).

To simulate blockage, close (or pinch off) the hose between the EPR outlet tee assembly and the instrument being cooled. Monitor the operating pressure of the unit. Turn the "T" handle until the desired relief pressure is set. (The EPR valve cannot be set lower than the total back pressure of the instrument being cooled or the instrument will not receive any flow.)

Tighten the locknut to secure the position of the "T" handle. Open the hose between the EPR outlet tee assembly and the instrument being cooled.

Section V Maintenance and Service



For personal safety and equipment reliability, the following procedure should only be performed by a competent technician. Contact our Service Department for assistance (see Preface, After-sale Support).

Service Contracts

NESLAB offers on-site Service Contracts that are designed to provide extended life and minimal down-time for your unit. For more information, contact our Service Department (see Preface, After-sale Support).

Draining the Reservoir

The CFT-300 is equipped with a ½ inch FPT DRAIN fitting located on the rear of the unit.

To drain the CFT-25 to CFT-150 reservoirs we recommend the use of a wet/dry vacuum. Remove the reservoir plug and carefully insert the wet/dry vacuum so as not to damage the cooling coils. **NOTE:** Tilting the unit more than 45° may allow compressor oil to seep into the suction line.

Cleaning

Reservoir

Periodically inspect the fluid inside the reservoir. If cleaning is necessary, flush the reservoir with a cleaning fluid compatible with the circulating system and the cooling fluid.

The cooling fluid should be replaced periodically. When operating at low temperatures, the concentration of water in the cooling fluid will increase over time, leading to a loss of cooling capacity.

Before changing the cooling fluid, raise the operating temperature of the unit to de-ice the cooling coils. Refer to Section III, Filling Requirements for instructions on replacing the cooling fluid.

Condenser

For proper operation, the unit needs to pull substantial amounts of air through a condenser. A build up of dust or debris on the fins of the condenser will lead to a loss of cooling capacity.

The lower front of the unit has a one-piece grille assembly. Gently pry the assembly off with a flathead screwdriver. Use care not to scratch the paint.

Periodic vacuuming of the condenser fins is necessary. The frequency of cleaning depends on the operating environment. We recommend a visual inspection of the condenser be made monthly after initial installation. After several months, the frequency of cleaning will be established.

Algae

To restrict the growth of algae in the reservoir, it is recommended that the reservoir cover be kept in place and that all circulation lines be opaque. This will eliminate the entrance of light which is required for the growth of most common algae.

NESLAB recommends the use of Chloramine-T, one gram per gallon.

Pump Strainer

Units with PD pumps have a strainer. Refer to the pump label on the rear of the unit to identify the type of pump in your unit.

If debris is in the system, the strainer will prevent the material from being drawn into the pump and damaging the pump vanes.

After initial installation, the strainer may become clogged with debris and scale. Therefore, the strainer must be cleaned after the first week of installation. After this first cleaning, a monthly visual inspection is recommended. After several months, the frequency of cleaning will be established.

Before cleaning the strainer, disconnect the power cord from the power source and drain the reservoir.

PD-1 pumps have a wire mesh strainer located in the pump head. PD-2 pumps have the strainer located in the pump suction line.

Remove the wrapper from the unit. Unscrew the larger of the two acorn nuts on the pump head and remove the screen.

Clean the screen by rinsing it with water.

When the screen is clean, replace it in the strainer, tighten the acorn nut and replace the wrapper. Refer to Section III, Filling Requirements for instructions on replacing the cooling fluid.

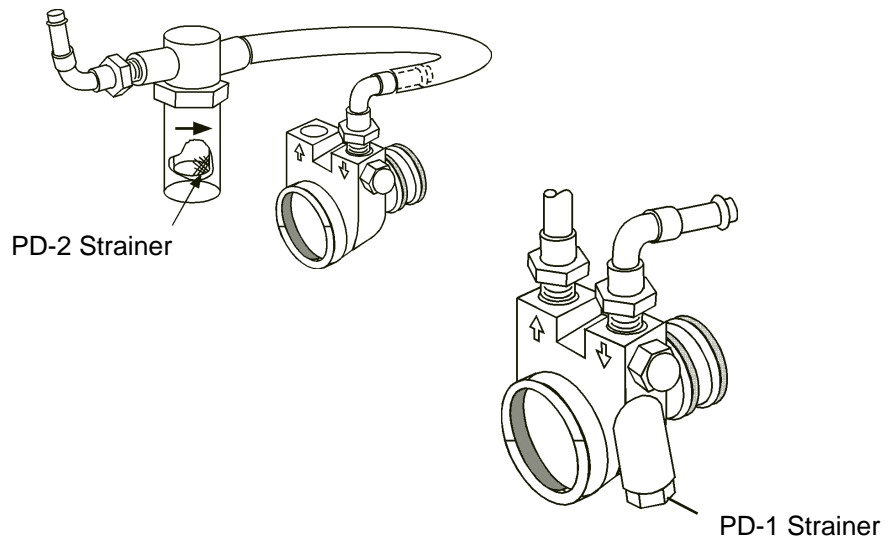

Pump Motor Lubrication

PD pump motors require periodic lubrication. Refer to the pump label on the rear of the unit to identify the type of pump in your unit.

PD pumps use sleeve type bearings with large reservoirs. Oiling instructions are generally posted on each motor. In the absence of instructions, add approximately 30 to 35 drops of SAE 20 non-detergent oil to each bearing on the following schedule (SAE 20 = 142 CS viscosity):

| Duty Cycle | Oiling Frequency |
|--------------|--------------------|
| Continuous | Once every year |
| Intermittent | Once every 2 years |
| Occasional | Once every 5 years |

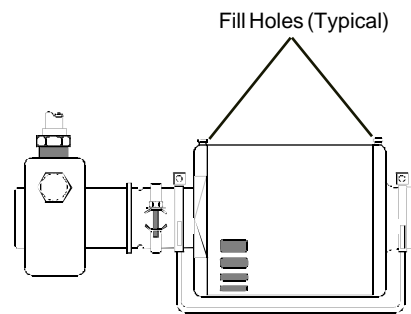

Hoses

The unit's internal and external hoses and clamps should be inspected and tightened on at least a semiannual basis.

Suction Discharge Pressure Speed Check

| Unit | Pump | Refrigerant | Suction PSIG | Discharge PSIG | Speed °C/Min |
|---------|-------|-------------|--------------|----------------|--------------|
| CFT-25 | PD-1 | R134a | 36 - 38 | 160 - 170 | 4.8 |
| CFT-25 | MD-30 | R134a | 25 - 28 | 145 - 160 | 4.0 |
| CFT-33 | PD1/2 | R134a | 42 - 45 | 180 - 200 | 3.0 |
| CFT-75 | PD1/2 | R134a | 37 - 41 | 170 - 185 | 4.6 |
| CFT-150 | PD2 | R22 | 70 | 270 | 2.8 |
| CFT-300 | PD2 | R22 | 88 - 94 | 265 - 280 | 6.8 |
| CFT-300 | CP-55 | R22 | 85 - 90 | 268 - 280 | 6.8 |

Standard temperature 60 Hertz units, derate 17% for 50 Hertz Units. +20°C fluid temperature, unit in the COOL mode, +20°C ambient. 100% water in the reservoir. Wrapper removed.

Section VI Troubleshooting

Checklist

Unit will not start

Check the line cord, make sure it is plugged in.

Check the voltage of the power source. Make sure it is within the rated voltage of the unit, $\pm 10\%$.

Check that the Power Switch/Circuit Breaker has not tripped.

Check the setting on the optional High Temperature Cutout.

CFT-300 units are equipped with high and low pressure switches. If either switch activates the unit will shut down. Once the cause has been determined you have to manually reset the switch. The switches are located behind the rear panel. (See Section IV, Operation on page 17.)

Unit will not circulate fluid

Check the reservoir level. Fill, if necessary.

Make sure the pump has been purged.

Check the pressure gauge (units with PD pumps). If the reading is 60 psig, check the instrument being cooled for restrictions in the cooling line.

Check the pump strainer (units with PD pumps). A clogged strainer can starve the pump.

Inadequate temperature control

If the temperature continues to rise, make sure the heat load of the instrument being cooled does not exceed the rated specification. (See Section II, Specifications on page 6.)

Make sure the air intake and discharge are not impeded and the ambient temperature does not exceed $+35^{\circ}\text{C}$.

Make sure the condenser is free of dust and debris. (See Section VI, Cleaning on page 20.)

If the compressor short-cycles (a clicking sound), check the line voltage. It should be within the 10% of the specified voltage. Wait 5 minutes before restarting the unit.

Service Assistance

If, after following these troubleshooting steps, your unit fails to operate properly, contact our Service Department for assistance (see Preface, After-sale Support). Before calling, please refer to the serial number label on the rear of the unit to obtain the following information:

- *unit BOM number*
- *unit serial number*
- *voltage of unit*
- *voltage of power source*

Pump Flow Diagram

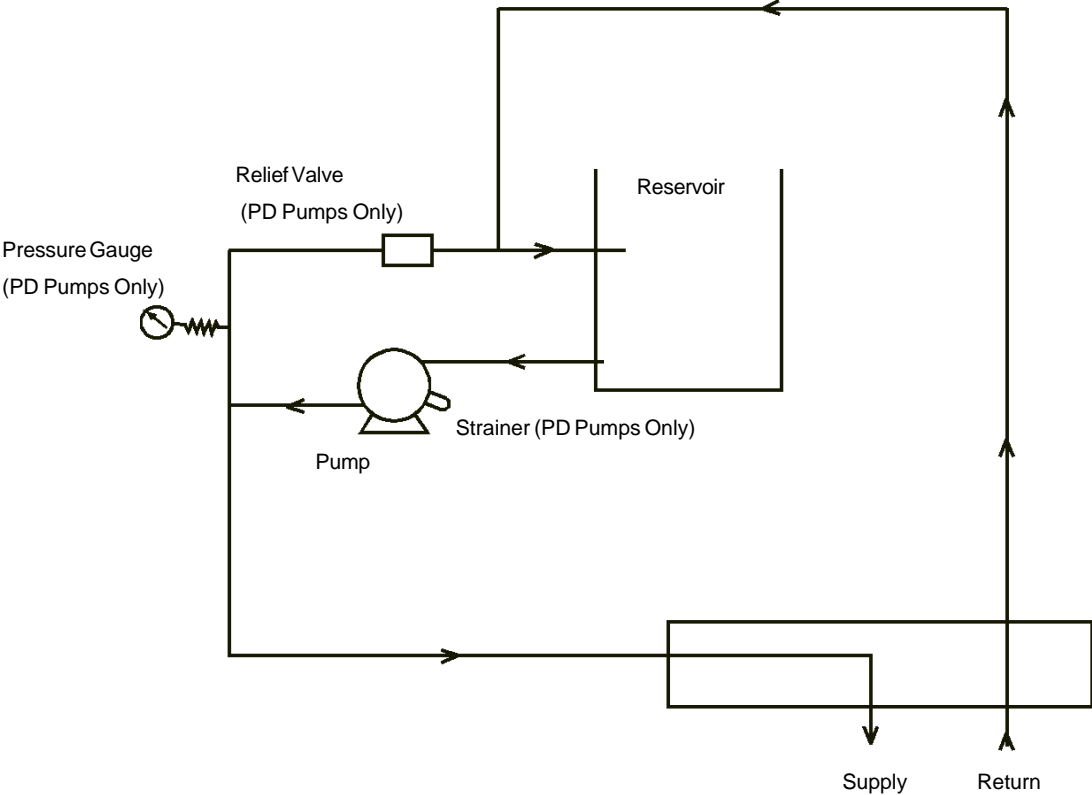

WARRANTY

NESLAB Instruments, Inc. warrants for 12 months from date of shipment any NESLAB unit according to the following terms.

Any part of the unit manufactured or supplied by NESLAB and found in the reasonable judgment of NESLAB to be defective in material or workmanship will be repaired at an authorized NESLAB Repair Depot without charge for parts or labor. The unit, including any defective part must be returned to an authorized NESLAB Repair Depot within the warranty period. The expense of returning the unit to the authorized NESLAB Repair Depot for warranty service will be paid for by the buyer. NESLAB's responsibility in respect to warranty claims is limited to performing the required repairs or replacements, and no claim of breach of warranty shall be cause for cancellation or rescission of the contract of sales of any unit.

With respect to units that qualify for field service repairs, NESLAB's responsibility is limited to the component parts necessary for the repair and the labor that is required on site to perform the repair. Any travel labor or mileage charges are the financial responsibility of the buyer.

The buyer shall be responsible for any evaluation or warranty service call (including labor charges) if no defects are found with the NESLAB product.

This warranty does not cover any unit that has been subject to misuse, neglect, or accident. This warranty does not apply to any damage to the unit that is the result of improper installation or maintenance, or to any unit that has been operated or maintained in any way contrary to the operating or maintenance instructions specified in NESLAB's Instruction and Operation Manual. This warranty does not cover any unit that has been altered or modified so as to change its intended use.

In addition, this warranty does not extend to repairs made by the use of parts, accessories, or fluids which are either incompatible with the unit or adversely affect its operation, performance, or durability.

NESLAB reserves the right to change or improve the design of any unit without assuming any obligation to modify any unit previously manufactured.

THE FOREGOING EXPRESS WARRANTY IS IN LIEU OF ALL OTHER WARRANTIES, EXPRESSED OR IMPLIED, INCLUDING BUT NOT LIMITED TO WARRANTIES OR MERCHANTABILITY AND FITNESS FOR A PARTICULAR PURPOSE.

NESLAB'S OBLIGATION UNDER THIS WARRANTY IS STRICTLY AND EXCLUSIVELY LIMITED TO THE REPAIR OR REPLACEMENT OF DEFECTIVE COMPONENT PARTS AND NESLAB DOES NOT ASSUME OR AUTHORIZE ANYONE TO ASSUME FOR IT ANY OTHER OBLIGATION.

NESLAB ASSUMES NO RESPONSIBILITY FOR INCIDENTAL, CONSEQUENTIAL, OR OTHER DAMAGES INCLUDING, BUT NOT LIMITED TO LOSS OR DAMAGE TO PROPERTY, LOSS OF PROFITS OR REVENUE, LOSS OF THE UNIT, LOSS OF TIME, OR INCONVENIENCE.

This warranty applies to units sold in the United States. Any units sold elsewhere are warranted by the affiliated marketing company of NESLAB Instruments, Inc. This warranty and all matters arising pursuant to it shall be governed by the law of the State of New Hampshire, United States. All legal actions brought in relation hereto shall be filed in the appropriate state or federal courts in New Hampshire, unless waived by NESLAB.