

**SONY**<sup>®</sup>

4-634-979-01

**CSP-960H/CSP-960S**

**Spressa 960<sup>TM</sup>**

**Drive Unit**

**Read First !**

Sony support line:

1-800-326-9551

**Installation Guide**

**SONY**<sup>®</sup>

**CSP-960H/CSP-960S**

**Spressa 960**<sup>™</sup>

***Drive Unit***

***Read First !***

***Installation Guide***

## **Trademarks and Copyrights**

- ❑ Sony and Spresa 960 are trademarks of Sony.
- ❑ Microsoft, MS-DOS and Windows are trademarks of Microsoft Corporation.
- ❑ IBM is a trademark of International Business Machines Corporation.

© 1997 Sony Electronics Inc. Reproduction in whole or in part without written permission is prohibited. All rights reserved.

# Table of Contents

---

|          |   |           |
|----------|---|-----------|
| <b>1</b> | <b>Introduction .....</b>                       | <b>1</b>  |
|          | 1-1. What's in the Box? .....                   | 1         |
|          | 1-2. System Requirements .....                  | 2         |
| <b>2</b> | <b>Installation .....</b>                       | <b>3</b>  |
|          | 2-1. System Analysis .....                      | 3         |
|          | 2-2. Spressa 960™ Drive Unit Installation ..... | 4         |
| <b>3</b> | <b>Troubleshooting .....</b>                    | <b>12</b> |
|          | 3-1. Technical Support .....                    | 12        |

# 1 Introduction

---

The Spresca 960™ Drive Unit contains a Sony Recordable CD-ROM (CD-R) which will enable you to record your own digital compact discs. You can create compact discs to store data, graphics, music, and multimedia presentations to name just a few of the many uses.

Installing the Spresca 960 Drive Unit requires you to reference several different manuals.

- ❑ Computer manuals
- ❑ SCSI Host Adapter Card manuals (for CSP-960H only)
- ❑ Sony CDU926S CD-R Drive Unit User's Guide

Use this manual as a guide to help you identify both the procedures and reference materials you need to use as you work your way through the installation procedure.

---

## 1-1 What's in the Box?

Your Spresca 960 Drive Unit should contain the following items. If all the items are not found, please contact your Sony dealer before proceeding.

- ❑ CSP-960H/960S CD-R Drive unit
- ❑ Software
  - Easy-CD Pro (CSP-960S only)
  - Direct CD (CSP-960H only)
- ❑ SCSI interface card (CSP-960H only)
- ❑ SCSI interface cable
- ❑ Audio cable
- ❑ Blank Spresca media
- ❑ Disc caddy
- ❑ Mounting screws
- ❑ User's guide
- ❑ Installation guide

---

## 1-2 System Requirements

Your computer system must contain at least the following components to successfully operate the Sprezza 960 Drive Unit.

### **Windows® 95**

- 8 MB RAM (16 MB Recommended)
- IBM<sup>®</sup>-Compatible, 486/33 or higher
- SCSI Adapter (for CSP-960H only)
- 1 available 5.25" internal drive bay
- 3.5" floppy disk drive
- Mouse (Microsoft<sup>®</sup>-compatible)
- Supports CD-ROM discs with digital audio extraction feature (CD-DA)
- Supports sound cards with 44 kHz, 16 bit stereo
- 20 Megs of available hard drive space

### **Windows 3.1**

- 8 MB RAM
- IBM-Compatible, 486/33 or higher
- MS-DOS<sup>™</sup>, version 5.0 or higher
- SCSI Adapter (for CSP-960H only)
- 1 available 5.25" internal drive bay
- 3.5" floppy disk drive
- Mouse (Microsoft-compatible)
- Supports CD-ROM discs with digital audio extraction feature (CD-DA)
- Supports sound cards with 44 kHz, 16 bit stereo
- 6 Megs of available hard drive space
- 530K of free conventional memory

## 2 Installation

---

Use this section as a guide while you work your way through the installation procedure. At times it will be necessary to refer to other manuals for more detailed technical information.

---

### 2-1 System Analysis

Before you can install the Spressa 960 Drive Unit you need to determine whether your computer can support the Sony CDU926S CD-R Drive Unit. Use the following instructions to help you configure your computer's operating system.

- 1 Determine whether your computer has a Bus Mastering SCSI Host Adapter Card installed. Please refer to your computer user's guide for additional information.
- 2 Determine whether your SCSI Host Adapter Card supports ASPI Manager.
  - ❑ If your computer *does not have ASPI Manager installed*, contact your SCSI Host Adapter Card vendor to obtain a copy. Please refer to your SCSI Host Adapter Card manual for additional information.
  - ❑ If your computer *does not support ASPI Manager*, purchase a SCSI Host Adapter Card which will support ASPI Manager. Please refer to your SCSI Host Adapter Card manual for additional information.

Your computer should be properly configured prior to the installation of the Spressa 960 Drive Unit. Proceed to the next section to begin the installation process.

---

## 2-2 Spressa 960 Drive Unit Installation

Your computer system should now be prepared for the installation of the Spressa 960 Drive Unit. Follow the instructions below to install the Sony CDU926S CD-R Drive Unit (CD-R drive).

- 1 Turn off the power to the computer and unplug the AC power cord.**
- 2 Remove the cover from the computer. Please refer to your computer user's guide.**

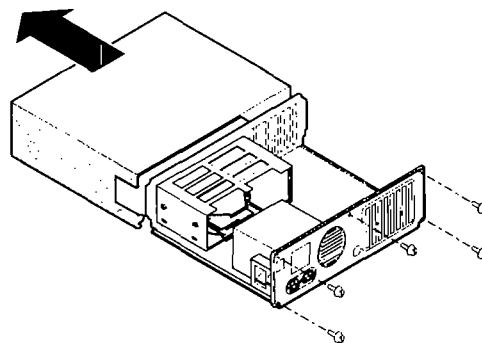

- 3 Remove the blank front panel covering the drive bay in which you will install the CD-R drive.**

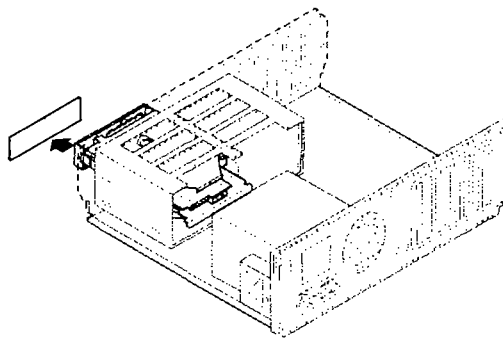



- 4 Attach one end of the supplied flat cable to the connector on the rear of the CD-R drive.

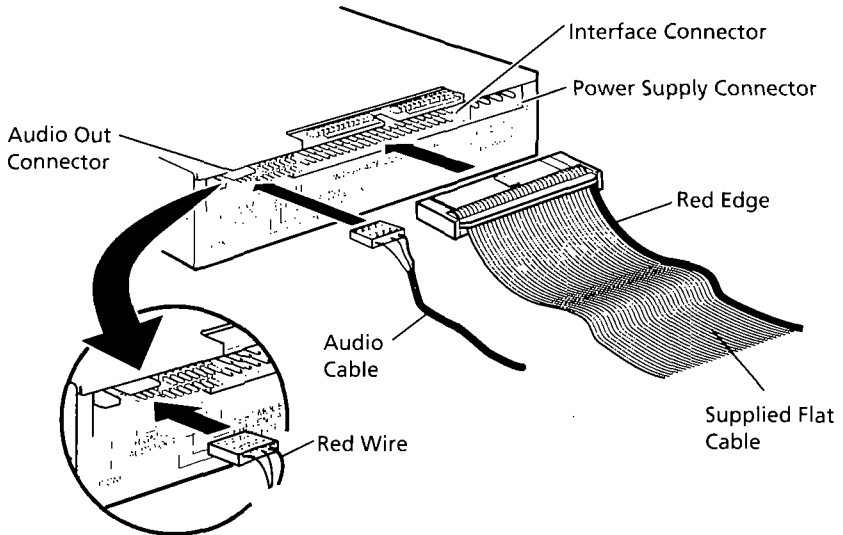

**Note**

*The red edge of the flat cable should be positioned next to the power supply connector. It is important that this cable be connected firmly and correctly.*



Flat Cable

Continue to next page →

**→ Continued**

- 5 Set the jumpers on the rear panel of the drive unit in accordance with the configuration of your computer system.

The jumpers are preset at the factory as illustrated below.

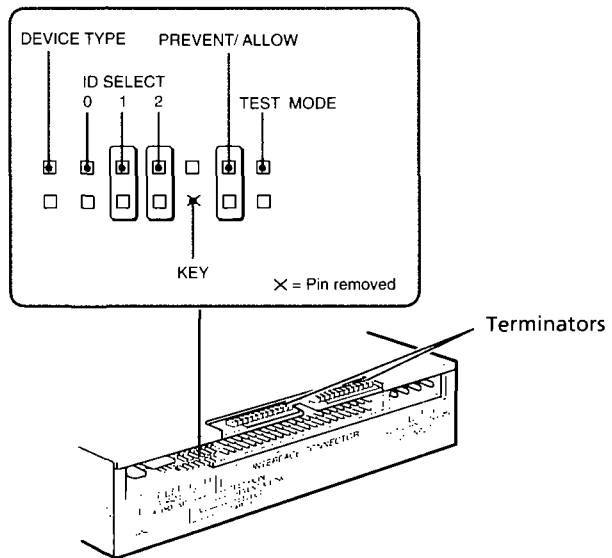

The following table describes the function of each jumper.

| Jumper        | Function  |           |                 |  |  |  |   |   |   |   |     |     |     |   |    |     |     |   |     |    |     |   |    |    |     |   |     |     |    |   |    |     |    |   |     |    |    |   |    |    |    |
|---------------|---|-----------|-----------------|--|--|--|---|---|---|---|-----|-----|-----|---|----|-----|-----|---|-----|----|-----|---|----|----|-----|---|-----|-----|----|---|----|-----|----|---|-----|----|----|---|----|----|----|
| DEVICE TYPE   | The setting of this jumper determines whether the SCSI device type code in the inquiry data is write once (WO) or CD-ROM.<br>ON: WORM (CD write once device)<br><input type="checkbox"/> OFF: CD-ROM  |           |                 |  |  |  |   |   |   |   |     |     |     |   |    |     |     |   |     |    |     |   |    |    |     |   |     |     |    |   |    |     |    |   |     |    |    |   |    |    |    |
| ID SELECT     | Assign the drive unit's ID number by setting these jumpers to ON or OFF. Do not assign the same number as one used for other SCSI devices. <table border="1" data-bbox="511 487 1036 863" style="margin-left: auto; margin-right: auto;"> <thead> <tr> <th>ID Number</th> <th colspan="3">Jumper settings</th> </tr> <tr> <td></td> <td>0</td> <td>1</td> <td>2</td> </tr> </thead> <tbody> <tr> <td>0</td> <td>OFF</td> <td>OFF</td> <td>OFF</td> </tr> <tr> <td>1</td> <td>ON</td> <td>OFF</td> <td>OFF</td> </tr> <tr> <td>2</td> <td>OFF</td> <td>ON</td> <td>OFF</td> </tr> <tr> <td>3</td> <td>ON</td> <td>ON</td> <td>OFF</td> </tr> <tr> <td>4</td> <td>OFF</td> <td>OFF</td> <td>ON</td> </tr> <tr> <td>5</td> <td>ON</td> <td>OFF</td> <td>ON</td> </tr> <tr> <td>6</td> <td>OFF</td> <td>ON</td> <td>ON</td> </tr> <tr> <td>7</td> <td>ON</td> <td>ON</td> <td>ON</td> </tr> </tbody> </table> | ID Number | Jumper settings |  |  |  | 0 | 1 | 2 | 0 | OFF | OFF | OFF | 1 | ON | OFF | OFF | 2 | OFF | ON | OFF | 3 | ON | ON | OFF | 4 | OFF | OFF | ON | 5 | ON | OFF | ON | 6 | OFF | ON | ON | 7 | ON | ON | ON |
| ID Number     | Jumper settings   |           |                 |  |  |  |   |   |   |   |     |     |     |   |    |     |     |   |     |    |     |   |    |    |     |   |     |     |    |   |    |     |    |   |     |    |    |   |    |    |    |
|               | 0   | 1         | 2               |  |  |  |   |   |   |   |     |     |     |   |    |     |     |   |     |    |     |   |    |    |     |   |     |     |    |   |    |     |    |   |     |    |    |   |    |    |    |
| 0             | OFF   | OFF       | OFF             |  |  |  |   |   |   |   |     |     |     |   |    |     |     |   |     |    |     |   |    |    |     |   |     |     |    |   |    |     |    |   |     |    |    |   |    |    |    |
| 1             | ON  | OFF       | OFF             |  |  |  |   |   |   |   |     |     |     |   |    |     |     |   |     |    |     |   |    |    |     |   |     |     |    |   |    |     |    |   |     |    |    |   |    |    |    |
| 2             | OFF   | ON        | OFF             |  |  |  |   |   |   |   |     |     |     |   |    |     |     |   |     |    |     |   |    |    |     |   |     |     |    |   |    |     |    |   |     |    |    |   |    |    |    |
| 3             | ON  | ON        | OFF             |  |  |  |   |   |   |   |     |     |     |   |    |     |     |   |     |    |     |   |    |    |     |   |     |     |    |   |    |     |    |   |     |    |    |   |    |    |    |
| 4             | OFF   | OFF       | ON              |  |  |  |   |   |   |   |     |     |     |   |    |     |     |   |     |    |     |   |    |    |     |   |     |     |    |   |    |     |    |   |     |    |    |   |    |    |    |
| 5             | ON  | OFF       | ON              |  |  |  |   |   |   |   |     |     |     |   |    |     |     |   |     |    |     |   |    |    |     |   |     |     |    |   |    |     |    |   |     |    |    |   |    |    |    |
| 6             | OFF   | ON        | ON              |  |  |  |   |   |   |   |     |     |     |   |    |     |     |   |     |    |     |   |    |    |     |   |     |     |    |   |    |     |    |   |     |    |    |   |    |    |    |
| 7             | ON  | ON        | ON              |  |  |  |   |   |   |   |     |     |     |   |    |     |     |   |     |    |     |   |    |    |     |   |     |     |    |   |    |     |    |   |     |    |    |   |    |    |    |
| KEY           | Used to prevent the SCSI bus interface connector from being plugged in upside down.   |           |                 |  |  |  |   |   |   |   |     |     |     |   |    |     |     |   |     |    |     |   |    |    |     |   |     |     |    |   |    |     |    |   |     |    |    |   |    |    |    |
| PREVENT/ALLOW | <input checked="" type="checkbox"/> ON: Allows insert and removal of a CD caddy with the eject button and the eject command.<br>OFF: Prevents insert and removal of a CD caddy with the eject button or an eject command.   |           |                 |  |  |  |   |   |   |   |     |     |     |   |    |     |     |   |     |    |     |   |    |    |     |   |     |     |    |   |    |     |    |   |     |    |    |   |    |    |    |
| TEST MODE     | ON: Enables test mode.<br><input checked="" type="checkbox"/> OFF: Enables normal operation.  |           |                 |  |  |  |   |   |   |   |     |     |     |   |    |     |     |   |     |    |     |   |    |    |     |   |     |     |    |   |    |     |    |   |     |    |    |   |    |    |    |

Factory settings

### Notes

- The upper row of pins is ground.
- ID SELECT, PREVENT/ALLOW, and TEST MODE are recognized when the power supply is turned on or SCSI is reset.
- TEST MODE is used exclusively for factory testing. Do not set TEST MODE to ON. Doing so may cause unexpected results.

**Continue to next page →**

→ Continued

- 6 Route the flat cable and audio cable through the drive bay from the front of the computer and insert the CD-R drive into the bay as shown. Secure the CD-R drive to the frame using the screws supplied.

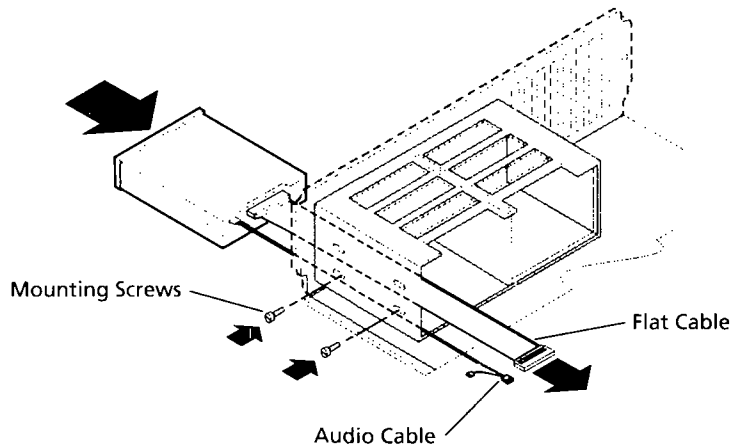

**Note**

*If you cannot secure the CD-R drive to the drive bay, you may need to install slide rails (not included) to the CD-R drive. Refer to your computer user's guide for additional information.*

- 7 Locate an available power supply cable inside your computer and connect it to the power supply connector on the rear of the CD-R drive as shown.

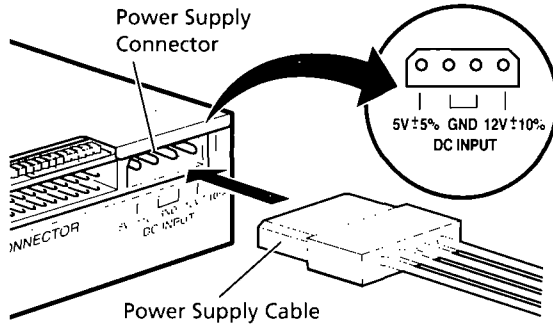

- ⚠ The power supply connector is designed to fit only one way. Do not attempt to force the cable in upside down, otherwise the CD-R drive will be damaged and the product warranty voided.

Continue to next page →

→ Continued

- 8 Connect the free end of the flat cable to the existing SCSI Host Adapter Card.

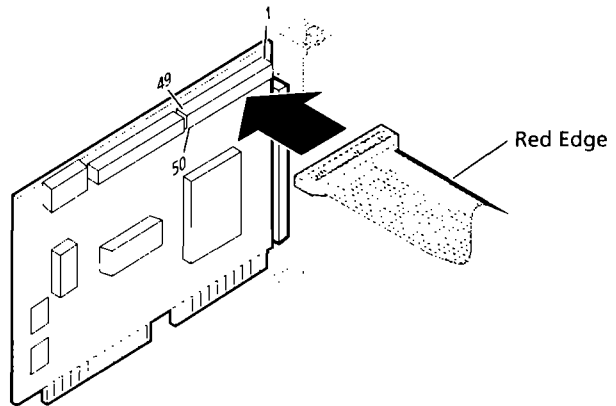

### Notes

- The red edge of the flat cable must be closest to pin number 1 of the interface card connector.
- The following illustration is a sample system configuration of the Sony CDU926S CD-R drive installation with a SCSI card.

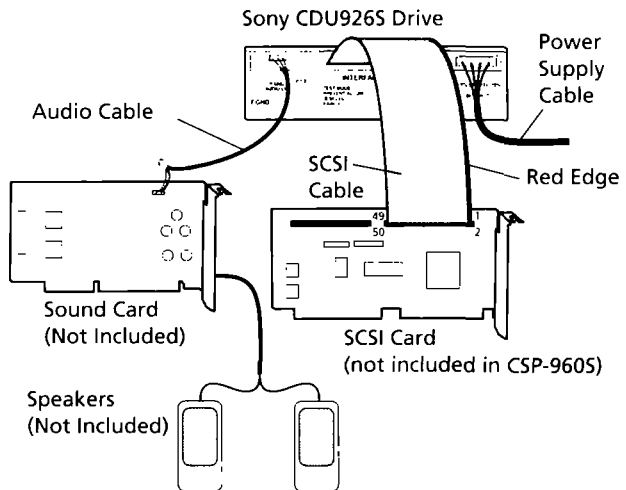

- 9 Replace the cover on the computer, being careful to reinstall all screws that were removed.

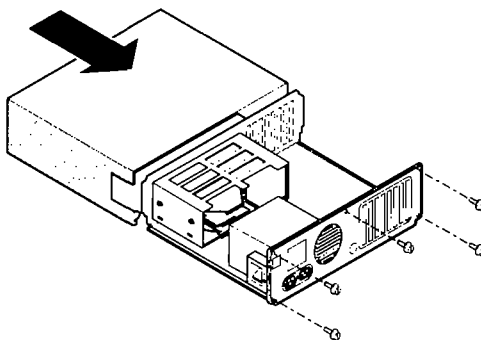

- 10 Replace the AC power cord and turn on your computer.

# 3 Troubleshooting

---

## 3-1 Technical Support

Should you require further assistance, please call the Sony technical support number for your country. One of Sony's Technical Support professionals will be happy to assist you.

### United States

|                     |   |
|---------------------|---|
| Technical Support:  | 1-800-326-9551  |
| FastFacts:          | 1-408-955-5505  |
| (Fax on Demand)     | 1-800-883-SONY (7669)   |
| Hours of Operation: | Monday – Friday<br>4:00 AM – 7:00 PM<br>(Pacific Standard Time)<br>Saturday<br>7:00 AM - 3:00 PM<br>(Pacific Standard Time) |

### Canada

|                     |   |
|---------------------|---|
| Technical Support:  | 1-416-499-1414 (CPI Division)                                   |
| FastFacts:          | 1-800-961-SONY (7669)   |
| (Fax on Demand)     |   |
| Hours of Operation: | Monday – Friday<br>9:00 AM – 5:00 PM<br>(Eastern Standard Time) |



*CSP-960H/CSP-960S*

# **Spressa 960™ Drive Unit**

Installation Guide