

OPERATION MANUAL

REV. 1.11 (20071128)

MPC-385

MICROMANIPULATOR SYSTEM

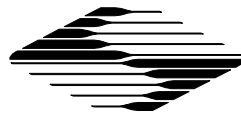

SUTTER INSTRUMENT

MP-385
MICROMANIPULATOR SYSTEM
OPERATION MANUAL
(REV. 1.11 (20071128))

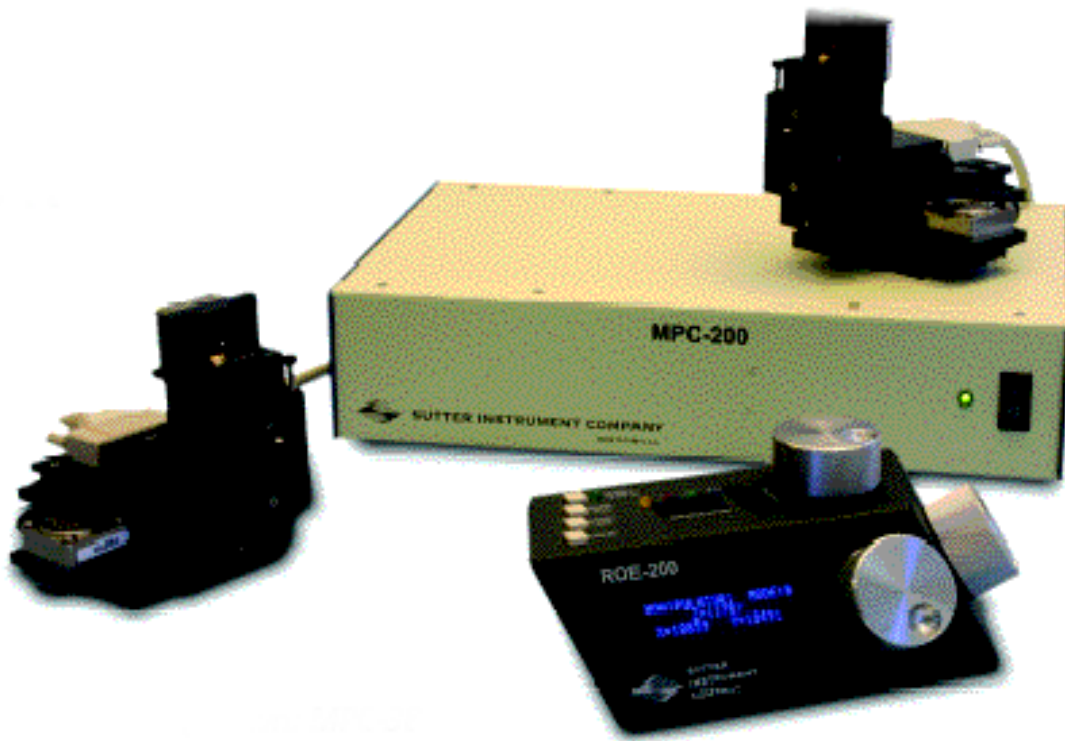

SUTTER INSTRUMENT COMPANY
ONE DIGITAL DRIVE
NOVATO, CA 94949

VOICE: 415-883-0128 WEB: WWW.SUTTER.COM
FAX: 415-883-0572 EMAIL: INFO@SUTTER.COM



Copyright © 2007 Sutter Instrument Company. All Rights Reserved.

TABLE OF CONTENTS

| | |
|--|-----------|
| 1. INTRODUCTION | 1 |
| 1.1 STRUCTURE OF THE MPC-385 DOCUMENTATION PACKAGE | 1 |
| 1.2 COMPONENTS OF THE MPC-385 | 1 |
| 2. MPC-200 MULTI-MANIPULATOR CONTROLLER AND ROE-200 INPUT DEVICE OPERATIONS | 3 |
| 2.1 ELECTRICAL CONNECTIONS AND INITIAL OPERATING INSTRUCTIONS | 3 |
| 2.2 INITIAL OPERATING INSTRUCTIONS | 3 |
| 2.3 MAIN CONTROLS ON THE ROE-200 | 4 |
| 2.3.1 <i>White Buttons:</i> | 4 |
| 2.3.2 <i>Black Selector Switches:</i> | 6 |
| 2.3.3 <i>Other Controls on the ROE-200</i> | 7 |
| 2.4 CONTROLS ON THE MPC-200 | 9 |
| 3. MP-285/M MANIPULATOR MECHANICAL MOUNTING INSTRUCTIONS | 13 |
| 3.1 MOUNTING MP-285/M TO A STAND OR PLATFORM..... | 13 |
| 3.2 SETTING HEADSTAGE/PIPETTE ANGLE AND PIPETTE EXCHANGE..... | 14 |
| 3.3 HEADSTAGE MOUNTING | 14 |
| 3.4 OTHER ACCESSORIES | 15 |
| 3.5 MINIMIZING ELECTRICAL NOISE | 16 |
| 3.6 INSTRUCTIONS USED IN SPECIAL INSTALLATIONS ONLY | 16 |
| 3.6.1 <i>Installing and Using the Right-Angle Adapter (285300)</i> | 16 |
| 3.6.2 <i>Instructions for Changing Handedness</i> | 16 |
| INDEX | 17 |

1. INTRODUCTION

1.1 Structure of the MPC-385 Documentation Package

The MPC-385 is a manipulator system comprised of the MPC-200 controller, the ROE-200 input device and the MP-285/M stepper motor manipulator. The manual consists of two parts, "Operations" that describes the functions of the MPC-200 controller and ROE input device and "Setup" that describes how to install the MP-285/M mechanical.

1.2 Components of the MPC-385

Carefully remove all components from the shipping container. In addition to this manual, the following should be included:

- MPC-200 controller
- ROE-200 Rotary Optical Encoder input device
- MP-285/M manipulator mechanical
- MP-225 Adapter box (adapts 3 wire MP-285/M mechanical to DB-25 cable)
- DB-25 cable (connects adapter box to the controller).
- RJ-45 cable (8 conductor) connects the ROE to the controller
- RJ-12 cable (6 conductor) daisy-chains two MPC-200 controllers
- USB cable for computer control of the MPC-385 system
- Power cable appropriate for your location
- X285210 mounting adapter plate and hardware to attach mechanical to a mounting surface
- X285204 four inch dovetail extension for mounting headstages
- Dovetail rod clamp
- 2.5mm hex wrench for removing the shipping screws
- 1.5mm hex wrench for adjusting pipette angle

IMPORTANT

Once you have unpacked your MPC-385, remove all 6 shipping screws, indicated by the red warning tags, from the MP-285/M. You must remove these screws before operating the manipulator. Save the screws, warning tags, and hex wrench in the event you need to transport your manipulator in the future. Once these screws have been removed, handle the micromanipulator with care. The mechanism can be damaged if the axes are moved with the screws in place.

2. MPC-200 MULTI-MANIPULATOR CONTROLLER AND ROE-200 INPUT DEVICE OPERATIONS

2.1 Electrical Connections and Initial Operating Instructions

Initially, you may want to simply connect your two manipulators, the controller, and the ROE together and try some gross movements in order to get a feel for the controls and how to make simple movements. It is perfectly acceptable to set the manipulators in the middle of a bench top, make all electrical connections and then observe each unit's movement by eye. Even if you wish to directly install the manipulators in your rig, it is useful to follow the initial setup procedure to learn how to move the units to allow easy access to the mounting screws.

1. Connect the power cord to the power entry module on the back of the MPC-200 controller.

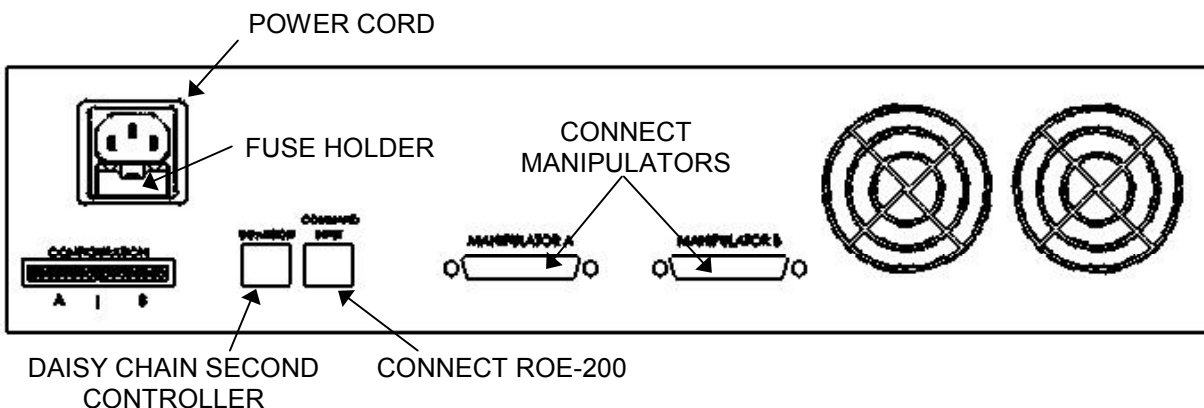

Figure 2-1. Rear of MPC-200 controller cabinet..

2. With the power OFF (front panel switch in the "0" position), connect the ROE-200 input box to the MPC-200 controller using the RJ-45 8-conductor cable. * Use the CONTROLLER output on the back of the ROE and the COMMAND INPUT on the back of the controller.
 3. With the power OFF, run a DB-25 cable from each of the two MP-285/M mechanicals to the DB-25 connectors marked "MANIPULATOR A" and "MANIPULATOR B" on the back of the controller.*
- **NOTE: Never connect or disconnect the ROE or the MP-285/M while the power is on!**

2.2 Initial Operating Instructions

After all electrical connections have been made, you can power up the MPC-385 using the 0/I switch on the front of the controller. As it initializes, you will see a start up screen on the ROE-200 that briefly displays the name of the device and the version of the installed firmware. As the power switch is the only control you will need to access on the MPC-200, the controller can ultimately be placed in an out of the way location (e.g. under your bench).

Once the start-up sequence has finished, you will see a display that gives the coordinates of the connected manipulator. The LED marked 1 will light if you connected the MP-285/M to the connector marked MANIPULATOR A. Confirm that you get a coordinate display and

that you have removed the shipping screws. If you do not get a coordinate display, go to the trouble shooting section at the back of the manual. If you have not yet removed the 6 shipping screws, turn the power back off and remove the six screws.

All functions necessary during normal operation are provided by 4 push buttons and two rocker switches on the top of the ROE-200. Other setup functions are done via buttons and DIP switches located on the back of the ROE-200 and DIP switches on the back of the MPC-200 controller.

The three ROE knobs control the three axes of the manipulator (right knob X, left knob Y, and top knob Z, see Page 5). Turn any one of the three knobs and notice that the corresponding axis moves and the coordinate for that axis changes.

The MPC-200 controller and ROE-200 have a built in Centering function. This is activated by pressing the white "CENTER" button on the back of the ROE. If the MP-285/M manipulator is sitting in a wide-open area, and the shipping screws are removed, press the CENTER button. The ROE-200 display will display the message "PLEASE WAIT MOVE IN PROGRESS". After the CENTER operation is complete, the manipulator axes will each be at the center of travel and the display will read 12500 for X, Y and Z.

From this location, you can move 12500 microns in each direction on each axis. The unit will stop automatically at each end of travel (00000 or 25000 microns). These ends are determined by firmware. Each axis also has magnetic end of travel switches that are not activated in normal operation. If the magnetic switches are activated, you will see the message EOT (for End Of Travel) on one of the displayed axes.

When the MPC-200 controller is first turned on, the speed of movement is at its fastest, coarsest Mode. Movement mode can be finer and slower by changing the black "Mode" toggle switch. As MODE increases from 0, smaller movements are commanded by the same turn of the ROE knob. MODE 5 or 6 is probably what you will use for the final approach to a cell. MODE 0, or "Accelerated Mode" is used for fast movements to move the pipette large distances. In MODE 0, when you turn the ROE knobs slowly, you get relatively slow movement that is useful for final moves to place a pipette near a cell. Conversely, when you make prolonged, rapid turns of the ROE knob, the controller/ROE automatically accelerates to maximum speed to allow for prolonged, long distance movements. This would be most useful for manual pipette exchange.

The remaining functions of the ROE are explained in the next section.

2.3 Main Controls on the ROE-200

2.3.1 White Buttons:

DIAG/NORM: Pressing the DIAG/NORM button will cause the green LED near the button to light, indicating the MPC-200/ROE-200 is in Diagonal mode. In this mode, rotation of the Z-axis knob produces diagonal movement. A second press will put the manipulator back into Normal mode. When in diagonal mode, the X and Y knobs remain active, allowing you to readjust the X and Y positioning of the pipette as you approach a cell in diagonal mode. Angle of diagonal mode movement is set via DIP switches on the back of the MPC-200 controller. (See Controller DIP switch setting instructions on Pages 9-10). When using MODE 9 (MODE toggle set to 9), Diagonal mode produces short, quick, impulse-like movement that may be useful in sharp pipette impalements.

When you switch to Diagonal mode, the ROE-200 display is changed from absolute to relative coordinates and the current location is set to 0,0,0. This allows users to invoke relative measurements using the display as a measuring device. A fourth coordinate that gives movement along the diagonal is also added for users who wish to measure the movement of along the axis coaxial with a pipette. When you return to Normal mode, the absolute coordinate system is recovered. The relative coordinate feature can be disabled via DIP switch 2 on back of the ROE-200.

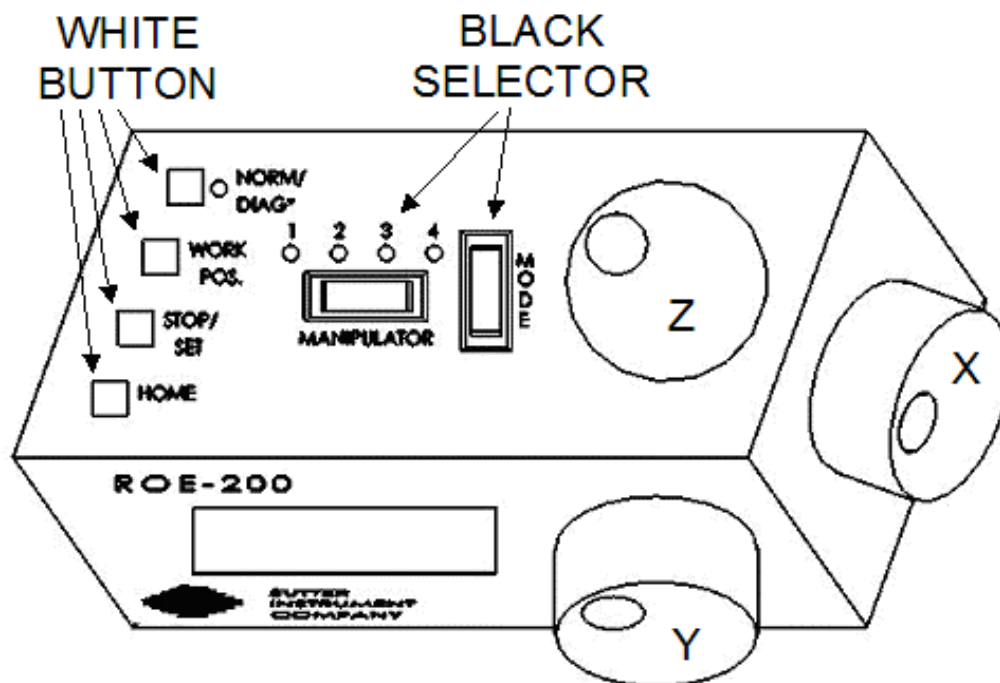

Figure 2-2. Top view of ROE-200..

HOME: When pressed, the manipulator will make a move along a stereotypic path to the location 0,0,0 or "home". Home is the location where you would most likely exchange your pipette and is maximal up on the Z-axis, maximal right on the X-axis (maximal left on a left-handed manipulator) and maximal front on the Y-axis. The stereotypic path of the movement is first along the currently set diagonal until either the X-axis or Z-axis reaches its origin (0). Which one of these occurs first is a function of the diagonal angle and the location at the time HOME is pressed. Once the first limit is reached, the unit will move the two remaining axes simultaneously to their origins (0). The only allowed change in this stereotyped move is that the Y-axis move can be eliminated. This is done via DIP switch 8 on the back of the MPC-200 controller. (See Controller DIP switch setting instructions on Page 11).

WORK POS.: This button has three functions:

1. With the STOP/SET button is held down, a momentary press of WORK POS. makes the current location the "Work Position". A beeper will sound to indicate that the operation is complete and the location has been saved. Typically, this is a location where the pipette tip is under the microscope objective and near the cells or tissue of interest.
2. Once you have defined a Work Position, a momentary press of WORK POS. will cause the manipulator to move to the defined Work Position, providing the manipulator last move was to Home. The move will occur along the predefined path that the manipulator moved

to get to Home (described above) but in the opposite direction. This is the reason why Work Position moves **must** follow Home moves; the move to Home defines the return trip. In either case, the movement along the diagonal as you come in and out of the preparation/dish/bath should assure that the pipette tip would not hit anything on the way in or out.

3. When WORK POS. is held down for longer than 2 seconds, the current manipulator is locked so that none of the buttons or the ROE knobs will cause it to move. The lock is released by holding WORK POS. down again. A beep will indicate that the lock is enabled or disabled and the display will indicate the locked state.

STOP/SET: This button has two functions:

1. When held down, STOP/SET" performs a "Set" function in combination with the "WORK POS." key. Think of it as a shift key when held down.
2. A momentary press of STOP/SET during a robotic move (see HOME, WORK POS. and CENTER) will immediately "Stop" the movement. **Think of this as your panic button when you see your pipette headed somewhere that you don't want it to go!**

2.3.2 Black Selector Switches:

MODE: The MODE Selector controls the speed and the relative fineness of movement of the manipulator produced by rotating the ROE knobs. As MODE increases from 0 to 9, the movement becomes finer and slower. As explained in "INITIAL OPERATING INSTRUCTIONS", MODE 0 is Accelerated Mode. In MODE 0, slow turns of the ROE knob produce medium course moves for moving a pipette under a microscope near a cell. Prolonged, fast turns of the ROE knobs cause the controller to accelerate to top speed for long, imprecise movements for rapid manual positioning of the pipette. The remaining MODES (1-9) produce moves of increasing sensitivity and decreasing speed. In practice, most users will find that MODE 5 or 6 will provide the necessary dexterity of movement for the final approach to a cell. The current MODE setting is displayed in the upper right of the ROE-200 display.

MANIPULATOR: The MANIPULATOR Selector toggles the active manipulator. In the MPC-325, there is only one active manipulator; therefore, the MANIPULATOR Selector has no function. You can toggle the switch, but no change will occur. With only one manipulator attached, the words "ROE-200" are displayed. If the manipulator is connected to the "MANIPULATOR A" output on the back of the MPC-200 controller LED 1 will be lit. If the manipulator is connected to the "MANIPULATOR B" output on the back of the MPC-200 controller LED 2 will be lit. If you connect an additional MP-225/M or MP-285/M manipulator in the future, the controller will automatically detect the second manipulator, the MANIPULATOR toggle will become active and the display will indicate which manipulator is active with the words "Drive A" or "Drive B"

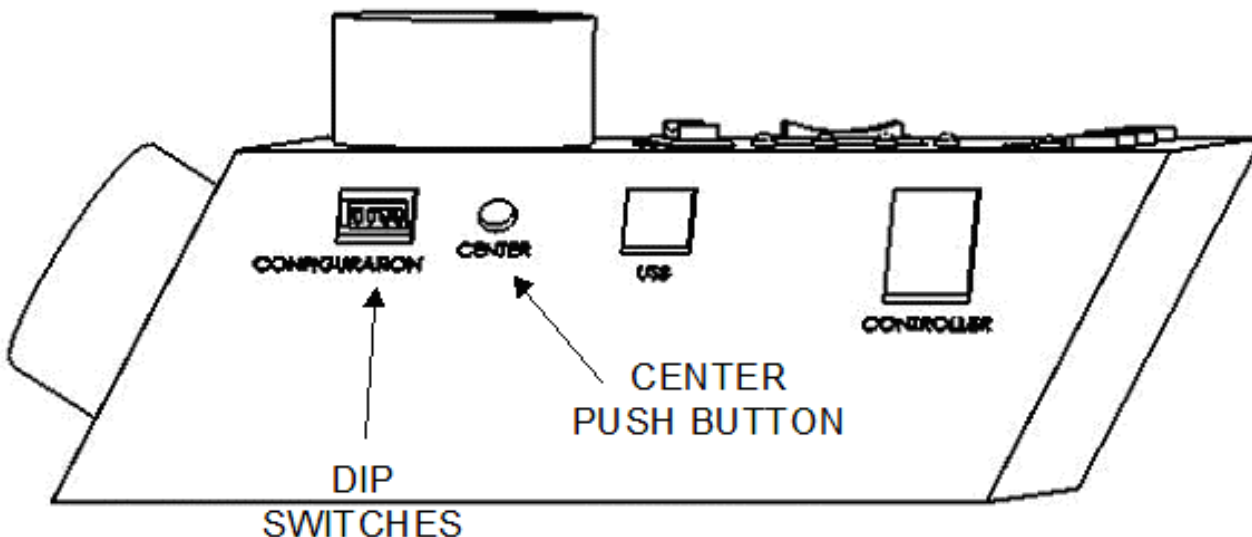

Figure 2-3. Side view of ROE-200..

2.3.3 Other Controls on the ROE-200

CENTER (round push button on the back of ROE-200): CENTER is an initialization function that is used when the unit is first set up and occasionally during normal operation. **CENTER should only be done in the absence of a pipette as the manipulator makes large robotic movements to its extreme ranges of motion.** To CENTER, press and release the white button on the back of the ROE-200. This will cause a prolonged movement in each axis to the end of travel (EOT) sensors beyond the origin (0,0,0). Once the sensors are found, a short move in the opposite direction is made and this location is defined as (0,0,0). Finally, the unit moves to the location (12500, 12500, 12500), the center of travel of each axis. If the unit is turned off, or STOP/SET is pressed during the running of CENTER, the unit will not be correctly initialized. In this case, it is necessary to cycle the power off and on and run CENTER again to its completion.

DIP Switches (on back of ROE-200): There are four DIP switches on the back of the ROE-200 which govern global and/or ROE settings.

Switch 1: When ON disables all MODES on the MODE Selector except for MODE 0 and 5. Some users may find that they only need Accelerated MODE and a single fine MODE. This will allow them to more easily switch between the two. Factory default is OFF, enabling all MODES.

Switch 2: When OFF, disables relative coordinates during Diagonal Mode. Factory default is ON, relative display enabled during Diagonal Mode.

Switch 3: When OFF, the MANIPULATOR Selector functions in a cyclical fashion. After reaching the highest number manipulator, a further push of MANIPULATOR cycles the user back to the lowest number manipulator. When DIP switch 3 is set to ON, the selector does not cycle back to the first manipulator. Factory default is OFF, allowing cycling back.

Switch 4: Reserved for future use. **Must be kept ON for proper functioning!**

NOTES

2.4 Controls on the MPC-200

Power Switch: The power switch for the MPC-200 is located on the front panel of the controller. At power up, the microprocessor in the ROE-200 scans the attached equipment and configures the system accordingly. Among the checks/configurations that are made:

1. Determines the number and type of manipulators that are attached. The MPC-200/ROE-200 system is able determine how many and what type of manipulators (MP-285/M or MP-225/M) are connected and to what outputs they are connected. It then sets the current for each output to the correct value for the mechanicals found. If no manipulators are found, the controller will return the message "NO MANIPULATOR DETECTED, PLEASE TURN OFF CONTROLLER AND ATTACH MANIPULATOR"
2. The ROE-200 is capable of connecting to more than one MPC-200 controller. On power up the ROE makes a determination of how many controllers are attached and configures properly. If the power is off on the second controller, the ROE-200 displays a message "PLEASE TURN ON ALL CONTROLLERS, THEN PRESS SET TO START".

DIP Switches: Two banks of eight DIP switches are located on the back of the MPC-200 controller. Each bank is assigned to (and configures) one of the two manipulator outputs on the back of the controller (MANIPULATOR A or B). Users familiar with the Sutter Instrument MP-225 controller will find that they have the same function as the configuration DIP switches on the MP-225 ROE. The switches are numbered 1 through 8. In all cases, the 0 or OFF position is opposite the direction of the switch number and the 1 or ON position is in the direction of the switch number and is also indicated by an arrow and the word "ON" next to Switch 1. In order for any new switch settings to take effect, the controller must be powered off and on.

The figure below shows the two banks of switches on the back of the MPC-200 controller.



Table 2-1. Configuration switch settings for different angles of steepness.

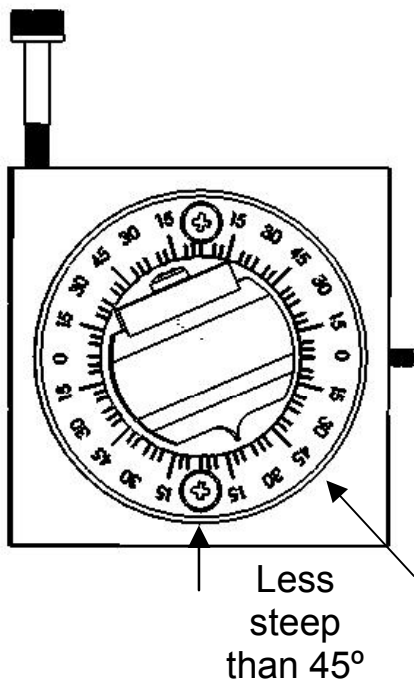

| Angle | DIP switch number | | | |
|-------|-------------------|---|---|---|
| | 1 | 2 | 3 | 4 |
| 7 | 1 | 1 | 1 | 1 |
| 11 | 0 | 1 | 1 | 1 |
| 14 | 1 | 0 | 1 | 1 |
| 21 | 0 | 0 | 1 | 1 |
| 27 | 1 | 1 | 0 | 1 |
| 29 * | 0 | 1 | 0 | 1 |
| 35 | 1 | 0 | 0 | 1 |
| 39 | 0 | 0 | 0 | 1 |
| 45 | 1 | 1 | 1 | 0 |

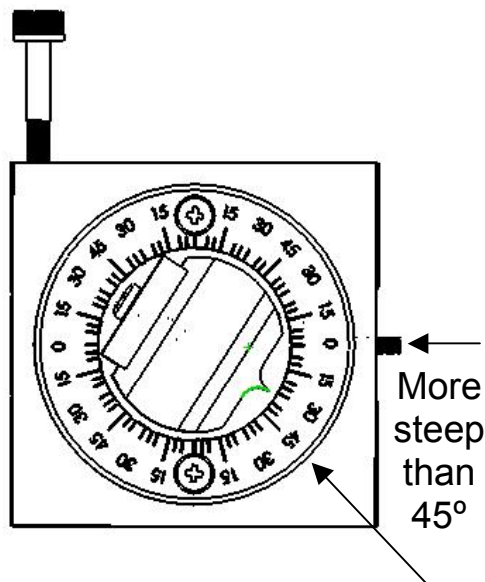

| Angle | DIP switch number | | | |
|-------|-------------------|---|---|---|
| | 1 | 2 | 3 | 4 |
| 39 | 0 | 1 | 1 | 0 |
| 35 | 1 | 0 | 1 | 0 |
| 29 | 0 | 0 | 1 | 0 |
| 27 | 1 | 1 | 0 | 0 |
| 21 | 0 | 1 | 0 | 0 |
| 14 | 1 | 0 | 0 | 0 |
| 11 | 0 | 0 | 0 | 0 |

*Factory default near 30 degrees

Switches 5, 6 and 7 set the direction of the movement produced by a clockwise turn (advancing right hand screw) of the ROE knob for each axis.

With the switch set to 0, a clockwise turn of the knob produces a decrement in the display; when the switch is set to 1, a clockwise turn of the knob produces an increment in the display. An increment in the display coincides with movement downward in the Z axis,

movement toward the rear of your setup in the Y axis and movement producing pipette advancement in the X axis.

The factory default is 1,1,1 for switches 5,6 and 7.

| | | | |
|--------------------|---|---|---|
| Switch number | 5 | 6 | 7 |
| Corresponding axis | X | Y | Z |

Switch 8 determines whether or not the Y axis is included in HOME and WORK POS. robotic moves. If switch 8 is set to 0, the Y axis is moved to a location where the pipette is towards the user in HOME move and is moved back to whatever Y coordinate was recorded during SET-WORK POS. in the WORK POS. move. If switch 8 is set to 1, the Y axis is not moved (Y position ignored) during the HOME or WORK POS. moves. The factory default for switch 8 is 0; the Y axis will move during HOME and WORK POS. moves.



Figure 2-5. Configuration switches (rear of MPC-200 controller).

3. MP-285/M MANIPULATOR MECHANICAL MOUNTING INSTRUCTIONS

The following sections describe how to mount your MP-285/M to a stand using the mounting adapter plate, how to adjust pipette angle and change pipettes, how to mount different headstages and finally, the modular nature of the mechanical.

3.1 Mounting MP-285/M to a Stand or Platform

The MP-285/M mounts to the mounting adapter plate (X285210) using four M3X0.5 hex head screws. The figure below shows how the adapter plate attaches to the manipulator:

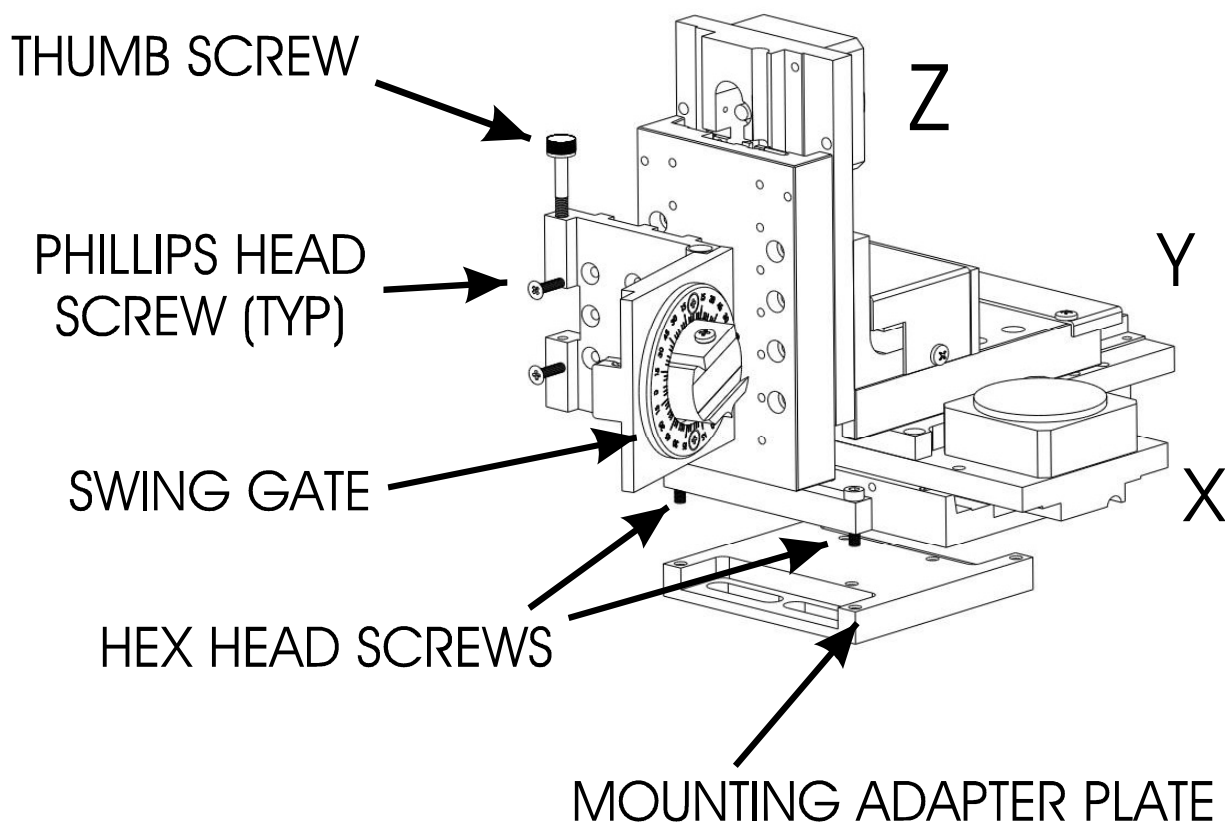

Figure 3-1. Angled side view of MP-285/M showing swing gate and mounting adapter plate.

Only the front pair of screws is visible in this figure. **The adapter plate is normally shipped in a small plastic bag also containing the necessary hardware.**

The figure above shows the plate removed from the X axis. Before attaching the adapter plate to the MP-285/M, you need to decide where to position the manipulator on your stand. The stand can be any flat surface carrying $\frac{1}{4}$ -20 or 10-32 holes on one-inch centers (such as a Sutter MT-stands or MD series platforms). A good technique is to set the manipulator on top of the adapter plate and slide it around on your stand until it is in a good location. Then take the manipulator off and fix the adapter plate securely to the stand with the $\frac{1}{4}$ -20 or 10-32 hardware. Finally, align the holes on the bottom corners of the manipulator with the four threaded holes on the corners of the adapter plate and attach the manipulator using the 4 supplied M3X0.5 metric cap screws.

3.2 Setting Headstage/Pipette Angle and Pipette Exchange

Mounted on the front of the Z axis of the manipulator is the “swing-out gate”. The swing-out gate is the mounting surface for the rotary dovetail that holds various electrophysiological headstages and/or micro tools at defined angles. The swing-out gate is also provides for easy exchange of pipettes during an experiment.

The angle of the rotary dovetail is adjusted by loosening the hex set screw located on the hinge side of the swing-out gate (see figure below). You can set a particular angle using the knife-edge on the dovetail and the scale on the faceplate. After choosing an angle, press the rotary dovetail firmly into the pocket in the swing gate and retighten the screw to fix the angle.

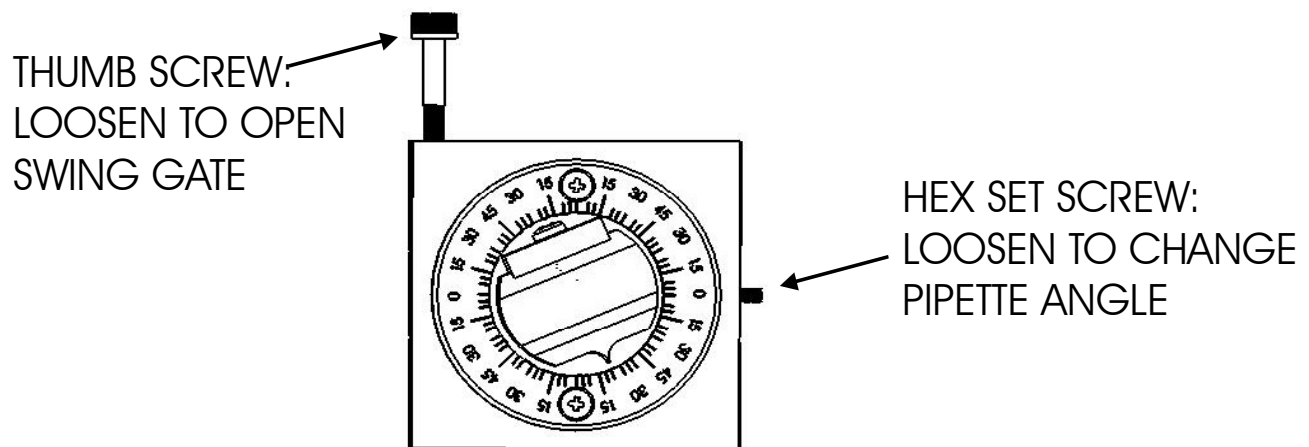

Figure 3-2. Locations of screws used to open swing gate and changing pipette angle.

To change pipettes, loosen the thumbscrew on the swing-out gate (above left). The gate will open allowing the headstage and holder to rotate almost 90 degrees. After replacing your pipette, make sure to close the gate tightly and tighten the thumbscrew securely while holding the gate closed. The thumbscrew is designed to pull the gate closed with tightening. Tightening with thumb and finger is sufficient.

The height of the swing-out gate on the front of the Z-axis is adjustable. To change the position, open the gate and loosen the four Phillips-head screws that mount the swing gate (see figure, Page **Error! Bookmark not defined.**). As shipped from the factory, the gate is positioned at the middle position on the Z-axis of the MP-285/M.

3.3 Headstage Mounting

Axon headstages 203B or CV-7 and the Heka EPC-10 headstage have an integral dovetail that slides directly into the rotary dovetail on the MP-285/M. The figure below shows an example of this type of headstage mounted in a left-handed manipulator and in profile (on

the right), the location of the Phillips-head screw that secures the headstage dovetail in its mate on the manipulator.

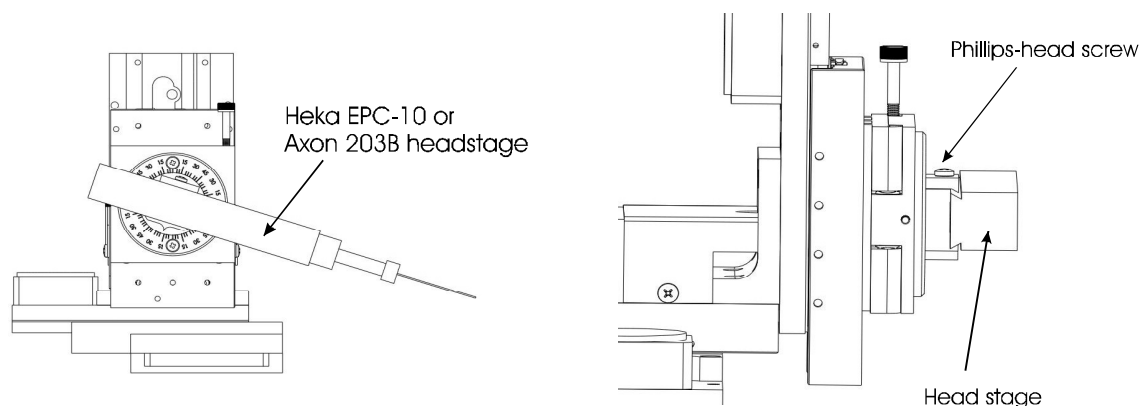

Figure 3-3. Headstage mounting.

Older Axon and Heka headstages mount using the 4-inch dovetail (X285204) and a plastic plate. A typical headstage of this type is shown mounted in a right-handed MP-285/M (right panel). The plastic plate used with the 4-inch dovetail is shown in the left panel of the figure and the holes are indicated to mount common headstages. Additional holes could be easily added to accommodate less common headstage footprints.

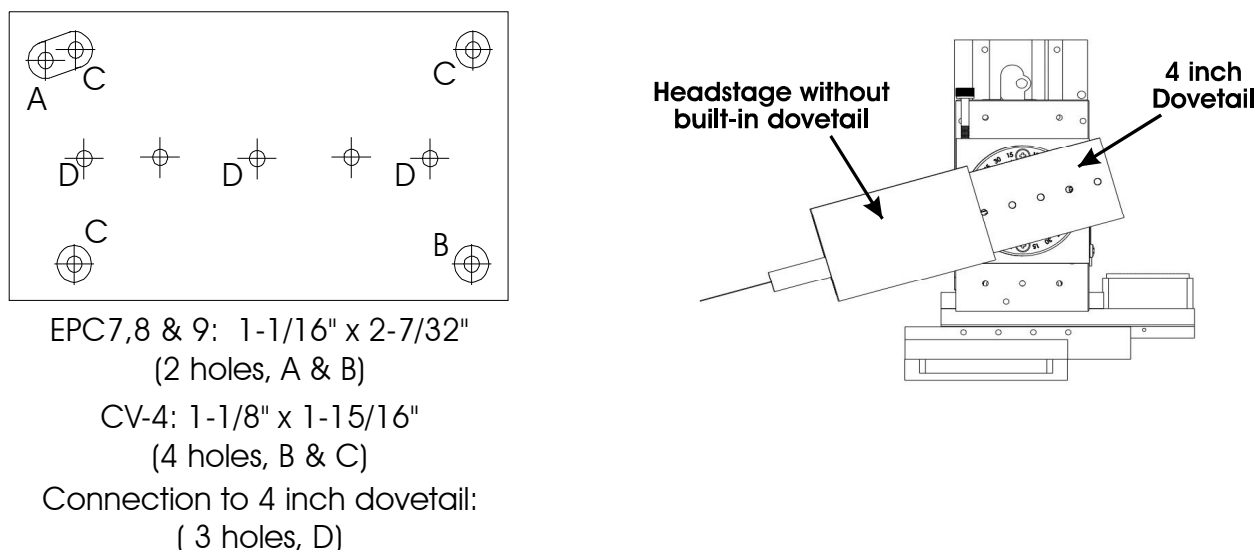

Figure 3-4. Using a dovetail for headstage mounting.

Rod mounted headstages and micro tools are accommodated by use of a rod clamp that fits into the dovetail (not shown). All the headstage adapters and mounting hardware are included with the manipulator and are shipped in a zip lock plastic bag.

3.4 Other Accessories

You may have received one or more accessories for mounting your MP-285/M and/or modifying the headstage mount to the manipulator (i.e. rotating base, microscope stage mount, gantry stand, dovetail extension). Setup of these accessories is normally covered in documentation accompanying the accessory.

If you intend to use the right angle adapter (285300) with your MP-285/M in order to rotate the manipulator 90 degrees, please see “Instructions used in Special Installations Only” below.

3.5 Minimizing Electrical Noise

We are aware of one potential noise source that users coupling their MP-325 with high-gain, high-input impedance, electrophysiological recording amplifiers may experience. Under certain circumstances, the manipulator and/or the drive cable coming from the controller may act as an antenna picking up electric field noise from nearby electrical equipment and bringing it into your setup. Grounding the manipulator will largely eliminate this noise source. Try to attach to one of the silver Phillips-head screws on the side of one or more of the axes. It should be noted that the manipulator produces negligible electrical noise when it is not moving because it is powered by a linear power supply with no AC current present.

3.6 Instructions Used in Special Installations Only

3.6.1 Installing and Using the Right-Angle Adapter (285300)

Open the swing-out gate and remove it from the front of the MP-285/M by removing the four Phillips-head screws. Next, install the right angle adapter on the front of the MP-285/M using the supplied M3-0.5 hex head screws. Finally, install the swing out gate on the right angle adapter using the four Phillips-head screws. With the right angle in place, the manipulator (right handed) can be turned 90 degrees clockwise so that its bulk faces to the right instead of the back of your microscope.

Having made the 90-degree rotation all the manual aspects of the manipulator will work normally. If you wish to use the automated features and diagonal movement mode of the MP-285/M you will need to change the configuration of the controller. To learn how to do this, please call Sutter at 415-883-0128 or email info@sutter.com.

3.6.2 Instructions for Changing Handedness

It is possible to change handedness of the MP-285 mechanical. If you wish to do this, please contact Sutter Instrument for details. If you wish, Sutter can change the handedness for you. We will charge for shipping only.

INDEX

C

| | |
|-------------------------------|------|
| Components..... | 1 |
| Controls..... | 4, 9 |
| MPC-200..... | 9 |
| DIP Switches | 9 |
| Power switch..... | 9 |
| ROE-200..... | 4 |
| black selector switches | 6 |
| other | |
| DIP switches..... | 7 |
| other..... | 7 |
| CENTER | 7 |
| white buttons..... | 4 |
| DIAG/NORM | 4 |
| HOME | 5 |
| STOP/SET | 6 |
| WORK POS | 5 |

E

| | |
|-----------------------------|---|
| Electrical Connections..... | 3 |
|-----------------------------|---|

I

| | |
|-------------------------------------|---|
| Initial Operating Instructions..... | 3 |
|-------------------------------------|---|

M

| | |
|---------------------------------------|----|
| Minimizing Electrical Noise | 16 |
| Mounting | |
| headstage..... | 15 |
| MP-285/M Manipulator Mechanical..... | 13 |
| MP-285/M to a Stand or Platform | 13 |

P

| | |
|-----------------------|----|
| Pipette Exchange..... | 14 |
|-----------------------|----|

S

| | |
|---|----|
| Setting Headstage/Pipette Angle..... | 14 |
| Special installations | |
| Installing and using right angle adapter..... | 16 |
| Instructions for changing handedness..... | 16 |

ADDENDUM

To

ALL OPERATION MANUALS OF MPC-200/ROE-200-EQUIPPED MPC-SERIES SYSTEMS

REV. 1.00 – NOVEMBER 28, 2007

As of Version 3.11 (November 12, 2007) of the firmware for the MPC-200 micromanipulator controller and ROE-200 input device, the CENTER routine associated with the white button on the rear of the ROE-200 has been replaced with a CALIBRATE routine that is less likely to break a pipette. Thus, it can be used in the middle of an experiment when you see the message EOT (end of travel) displayed on the ROE-200. Please note that all references to CENTER in the current manual should be replaced with CALIBRATE. Furthermore, the detailed instructions regarding the centering routine in section 2.3.3 should be replaced with the CALIBRATE instructions below.

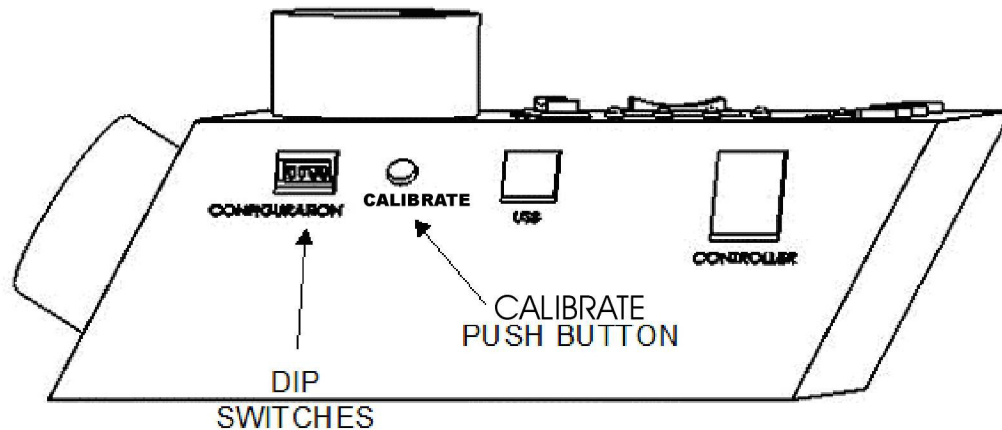

Figure 1. Location of the CALIBRATE button on the ROE-200.

CALIBRATE is used in two ways. When the unit is first set up, CALIBRATE is used to establish the zero location. Then, occasionally, during normal operation, CALIBRATE is used to reestablish the zero location. CALIBRATE follows a more conservative path than CENTER, and can generally be used in the presence of a pipette.

To CALIBRATE, press and release the white button on the back of the ROE-200. The manipulator will back away from the current location along the established diagonal (like a HOME move), and ultimately move to the end of travel (EOT) sensors, beyond the origin (0,0,0). Once the sensors are found, a short move in the opposite direction is made and this location is defined as (0,0,0). The purpose of CALIBRATE is to allow 0,0,0 or HOME to be safely reestablished during the course of an experiment without risking damage to the pipette.

If the unit is turned off, or STOP/SET is pressed during the running of CALIBRATE, the unit will not be correctly initialized. In this case, it is necessary to cycle the power off and on, and then run CALIBRATE again to its completion.