

Installation and Operation Manual

Thermo Scientific Revco® PLUS Series Ultra-Low Temperature Freezers



© 2007 Thermo Fisher Scientific. All rights reserved.

“Suva®” is a registered trademark of DuPont.

All other trademarks are the property of Thermo Fisher Scientific Inc. and its subsidiaries.

Table of Contents

1	About Ultra-Low Temperature Freezers	1
2	Safety Precautions	1
3	Unpacking	1
4	General Recommendations	2
4.1	Initial Loading	2
5	Operating Standards	2
6	Installation	2
6.1	Location	2
6.2	Wiring	2
6.3	Leveling	2
6.4	Door Operation	3
6.4.1	Opening the Door	3
6.4.2	Closing the Door	3
6.5	Pressure Equalization Port	3
6.6	Remote Alarm Contacts (optional)	3
7	Control Panel (Revco Ultima PLUS and Elite PLUS models)	4
8	Start Up and Operation (Revco Ultima PLUS and Elite PLUS)	5
8.1	Turning the Power On	5
8.2	Error Messages	5
8.3	Setting the Cabinet Temperature	5
8.4	Setting the Alarms (Revco Ultima PLUS and Elite PLUS)	5
8.5	Recording Excursions and Resetting Alarms	6
8.5.1	Automatic Incident Monitor	6
8.5.2	Alarm Reset	6
8.6	Alarm Test	6
8.7	Program Mode	7
9	Revco Value PLUS Models – Operation	8
9.1	Revco Value PLUS Control Panel	8
9.2	Turning the Power On	8

9.3 Error Messages	8
9.4 Setting the Cabinet Temperature	9
9.5 Alarm Operation	9
9.5.1 Setting the Alarms	9
9.5.2 Silencing the Alarms	9
10 Backup System (Optional)	9
10.1 CO ₂ and LN ₂ Precautions	9
10.2 Installation	9
10.3 Startup	9
10.4 Operation	10
10.5 System Status Lights	10
11 Maintenance and Troubleshooting	10
11.1 Cleaning the Condenser	10
11.2 Cleaning the Condenser Filter	10
11.3 Gasket Maintenance	10
11.4 Defrosting the Freezer	10
11.5 Alarm Battery Maintenance	10
11.6 Troubleshooting Procedures	10
12 Chart Recorders	11
12.1 Set Up and Operation	11
12.2 Changing Chart Paper	11
12.3 Calibration Adjustment	11

1 About Ultra-Low Temperature Freezers

All of the ultra-low temperature freezers described in this manual feature a combination of advanced technologies designed specifically to provide optimal reliability in low-temperature applications.

Ultra-low systems include:

- DuPont Suva® refrigerants selected to provide maximum cooling capacity under low-temperature conditions
- A field-proven cascade refrigeration system design.

All upright models include a pressure equalization port to combat the vacuum created after door openings.

2 Safety Precautions

In this manual and on labels attached to this product, the words WARNING and CAUTION mean the following:







- **WARNING:** a potentially hazardous situation which, if not avoided, could result in serious injury or death.
- **CAUTION:** a potentially hazardous situation which, if not avoided, may result in minor or moderate injury or damage to the equipment.

Before installing, using or maintaining this product, please be sure to read this manual and product warning labels carefully. Failure to follow these instructions may cause this product to malfunction, which could result in injury or damage.

Below are important safety precautions that apply to this product:

- Use this product only in the way described in the product literature and in this manual. Before using it, verify that this product is suitable for its intended use.
- Do not modify system components, especially the controller. Use OEM exact replacement equipment or parts. Before use, confirm that the product has not been altered in any way.
- Your unit must be properly grounded in conformity with national and local electrical codes. Never connect the unit to overloaded power sources.
- Disconnect the unit from all power sources before cleaning, troubleshooting, or performing other maintenance on the product or its controls.

The following symbols are used in caution, warning and informational labels attached to the freezer:

	caution, info		on
	electrical hazard	○	off
	hot surface	⦿	on (control panel)
	cold surface	○	off (control panel)
	watch hands	⏻	standby (battery enable)
	protective conductor terminal		
	alternating current	⏚	earth ground

3 Unpacking

At delivery, examine the exterior for physical damage while the carrier's representative is present. If exterior damage is present, carefully unpack and inspect the unit and all accessories for damage.

If there is no exterior damage, unpack and inspect the equipment within five days of delivery. If you find any damage, keep the packing materials and immediately report the damage to the carrier. Do not return goods to the manufacturer without written authorization. When submitting a claim for shipping damage, request that the carrier inspect the shipping container and equipment.

4 General Recommendations

This refrigeration system is designed to maintain ultra-low temperatures with safety in a +32°C (90°F) ambient environment, **only** when the freezer is used for storage.



WARNING! This unit is not a “rapid-freeze” device. Freezing large quantities of liquid, or high-water content items, will temporarily increase the chamber temperature and will cause the compressors to operate for a prolonged time period.

Avoid opening the door for extended time periods since chamber temperature air will escape rapidly. Also, keep the inner doors closed as much as possible. When room air, which is higher in humidity, replaces chamber air, frost may develop in the chamber more rapidly.

4.1 Initial Loading

After reading and completing the Safety Considerations, Pre-Installation, Installation, and Operation sections of this manual, start up the freezer following the instructions in Section 8.1 on page 5.

Allow the freezer to operate at the desired temperature for a minimum of 12 hours before loading.

Load the freezer one shelf at a time, beginning with the top shelf. After loading each shelf, allow the freezer to recover to the desired setpoint before loading the next shelf. Repeat this process until the freezer is fully loaded.



CAUTION! Failure to follow these procedures or overloading the unit may cause undue stress on the compressors or jeopardize user product safety.

5 Operating Standards

The freezers described in this manual are classified for use as stationary equipment in a Pollution Degree 2 and Overvoltage Category II environment.

These units are designed to operate under the following environmental conditions:

- Indoor use
- Altitude up to 2000m
- Maximum relative humidity 60% for temperatures up to 32°C (90°F)
- Main supply voltage fluctuations not to exceed 10% of the nominal voltage.

6 Installation

Do not exceed the electrical and temperature ratings printed on the dataplate located on the lower left side of the unit.



CAUTION! Improper operation of the equipment could result in dangerous conditions. To preclude hazard and minimize risk, follow all instructions and operate within the design limits noted on the dataplate.

6.1 Location

Install the unit in a level area free from vibration with a minimum of five inches of space on the top and back, eight inches on each side. Refer to Section 6.3 for further instructions on leveling cabinets. Allow enough clearance so that door can swing open at least 90 degrees.

Do not position the equipment in direct sunlight or near heating diffusers, radiators, or other sources of heat. The ambient temperature range at the location must be 59 to 90°F (15 to 32°C).



CAUTION! To allow for proper air flow, a minimum of six inches of clearance space is required on the sides, top and rear of the freezer.

6.2 Wiring



CAUTION! Connect the equipment to the correct power source. Incorrect voltage can result in severe damage to the equipment.



CAUTION! For personal safety and trouble-free operation, this unit must be properly grounded before it is used. Failure to ground the equipment may cause personal injury or damage to the equipment. Always conform to the National Electrical Code and local codes. Do not connect the unit to overloaded power lines.



CAUTION! Do not position the unit in a way that impedes access to the disconnecting device or circuit breaker in the back of the unit.

Always connect the freezer to a dedicated (separate) circuit. Each freezer is equipped with a service cord and plug designed to connect it to a power outlet which delivers the correct voltage. Supply voltage must be within +10% or -10% of the freezer rated voltage.



CAUTION! Never cut the grounding prong from the service cord plug. If the prong is removed, the warranty is invalidated.

6.3 Leveling

Make sure that the floor is level. The unit must be level both front to back and side to side.

6.4 Door Operation

Upright freezer models are equipped with an advanced Cryolatch™ assembly specifically designed for ultra-low temperature freezers.

Features include:

- One-hand operation
- A front-accessible lock, keyed to match the freezer control lock
- Hasps for a standard padlock to provide additional security
- Durable construction for reliable operation and safe product storage.



CAUTION! When moving the freezer, always grasp cabinet surfaces; never pull the freezer by the latch handle.

6.4.1 Opening the Door

1. Remove the padlock if you have one.
2. Move the key into the open position by rotating it counter-clockwise.
3. Grasp the latch handle (preferably with your left hand) and pull it toward yourself until the latch disengages from the cabinet strike.
4. Keep pulling by the latch handle or the integrated door handle to open the main door.

6.4.2 Closing the Door

Note that the latch does not self-engage automatically when you close the door. You must rotate the latch into the open position first.

1. Grasp the latch handle (preferably with your left hand) and pull it toward yourself, rotating the latch into the open position.
2. Move the freezer door into the closed position and gently push the handle away from you, making sure that the latch engages fully with the cabinet strike.



CAUTION! Closing the door without making sure the latch engages fully with the strike can result in substantial prying forces on the door.

3. Keep applying gentle pressure to the latch handle until the latch is securely in closed position.
4. Insert the key and rotate clockwise to lock.
5. Replace the padlock if you are using one.

6.5 Pressure Equalization Port

When an upright ultra-low temperature freezer door is opened, room temperature air rushes into the storage compartment. When the door is closed, the fixed volume of air is cooled rapidly. Pressure drops below atmospheric pressure, resulting in a substantial vacuum. Re-entry into the cabinet is impossible until internal pressures are returned to atmospheric pressure. Without a pressure equalization mechanism, it can take, in extreme cases, several hours before the door can easily be reopened.

All upright models feature a port that provides vacuum relief after door openings.

The pressure equalization port is located in the door behind the eye-level panel on the front of the freezer. Although the port is designed to self-defrost, excessive frost accumulation on the inner door could eventually restrict air flow. Therefore you should periodically inspect the inner door and brush away any loose frost using a stiff nylon brush.

6.6 Remote Alarm Contacts (optional)

If you are using a remote alarm system, you need to install the remote alarm connector provided with your freezer.

The remote alarm contacts are located on the back of the freezer above and to the left of the power switch. After installing the wiring from the remote alarm to the connector, install the connector to the freezer microboard.

When the unit is in the alarm condition:

- The leftmost pin (#7) is NO (normally open) output.
- The second pin from the left (#6) is COM (common).
- The third pin from the left (#5) is NC (normally closed).

The contacts will trip in the event of a power outage, high temperature alarm or low temperature alarm.

7 Control Panel (Revco Ultima PLUS and Elite PLUS models)

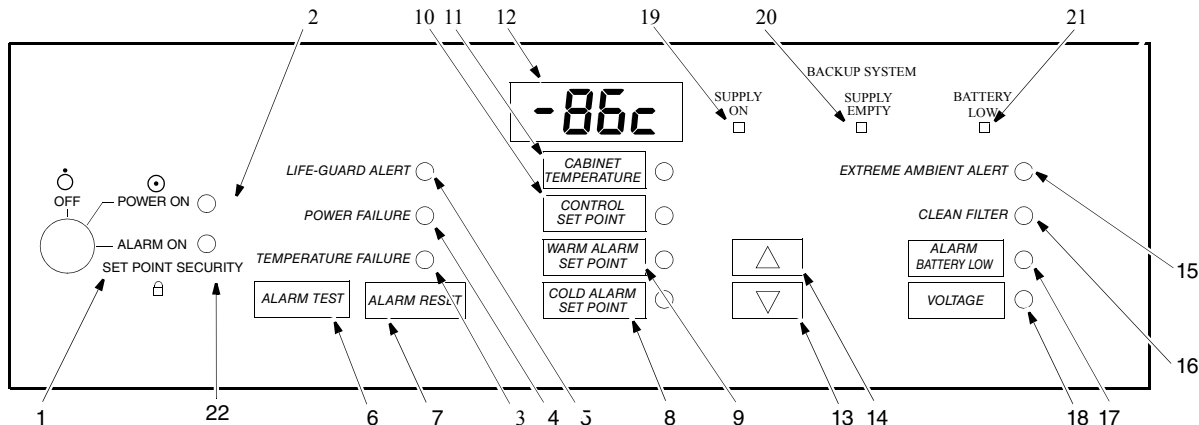

Figure 1. Revco Ultima PLUS Series Control Panel with Optional Backup System

Before the initial start up, take some time to become familiar with the controls on your freezer. Figure 1 illustrates the Revco Ultima PLUS upright freezer control panel.

Note: *Figure 1 shows all possible functions. These functions vary depending on the model and options. You may not have all of the functions on your equipment. Refer to the descriptions below for functions that are only available for Revco Ultima PLUS models or models that have the backup system option.*

1. Three position keyed Power On Switch.
2. Power On Indicator. This green LED lights when power is connected to the freezer and the key switch is in the ON position.
3. Temperature Failure Indicator. This indicator lights when the freezer temperature deviates either above or below the alarm temperature settings.
4. Power Failure Indicator. This indicator lights when there is a power failure to the freezer.
5. Life-Guard Alert Indicator (Revco Ultima PLUS Models only.) This indicator lights when the first stage compressor has gone into a cautionary state of operation to help prevent failure.
6. Alarm Test Pad. Press this pad to start an alarm test (refer to Section 8.5 on page 6).
7. Alarm Reset Pad. Press this pad to reset *slowly* blinking indicators. Slowly blinking indicators denote that the condition *has* occurred but is now within the given operating parameters. This pad is also depressed to temporarily silence the audible alarm.
8. Cold Alarm Setpoint. Press this pad to display the cold alarm setpoint (refer to Section 8.4 on page 5).
9. Warm Alarm Setpoint. Press this pad to display the warm alarm setpoint (refer to Section 8.4 on page 5).
10. Control Setpoint. Press this pad to set the cabinet temperature (refer to Section 8.3 on page 5).
11. Cabinet Temperature Indicator. Displays cabinet temperature in operating mode, parameters and values when in program mode (refer to Section 8.7 on page 7).

12. Digital Temperature Display Window. This window displays chamber temperature, alarm values, etc. depending on the operating status of the freezer and the procedure being performed.
13. Decrement Pad (▽). Use this pad to decrease temperature values.
14. Increment Pad (△). Use this pad to increase temperature values.
15. Extreme Ambient Alert (Revco Ultima PLUS Models only). This indicator lights when the ambient temperature has exceeded the upper limit of the recommended operating range. If the Extreme Ambient Alert is activated, the ambient environment needs to be improved for proper function of the freezer.
16. Clean Filter Indicator. This indicator lights when the air cooled condenser filter is dirty.
17. Alarm Battery Low Indicator. This indicator lights when the charge on the alarm battery is low. Press this button to display the battery charge (in volts) in the digital display window.
18. Voltage Indicator. Press this pad to display the current line voltage in the digital display window. A built-in power management system boosts voltage when it is low and lowers voltage when it is high.
22. Alarm On/Set Point Security Indicator. This indicator lights when the alarm is activated. Also indicates that Setpoint Security is activated (Revco Ultima PLUS Models only).

The following indicators are available only when the freezer is equipped with the optional backup system (refer to Section 10.5 on page 10).

19. Backup System Supply On Indicator.
20. Backup System Supply Empty Indicator
21. Backup System Battery Low Indicator.

8 Start Up and Operation (Revco Ultima PLUS and Elite PLUS)

Refer to Figure 1 on page 4 as you complete the following procedures.

8.1 Turning the Power On

To start up your freezer, complete the following steps:

1. Plug the freezer into the power outlet.
2. Turn the power switch in back of the freezer, on the bottom right, to the ON position.
3. **If you do not have the CO₂/LN₂ backup option installed**, remove the panel near the lower left corner of the front of the freezer and turn on the Battery Enable switch. Replace the panel.

If you do have the CO₂/LN₂ backup option installed, wait until the freezer has pulled down to operating setpoint before turning on the Battery Enable switch. Refer to Section 10 on page 9 for backup system installation and operation instructions.

4. Turn the key switch to the POWER ON position. The Power On LED and the Cabinet Temperature LED illuminate.

The Low Battery indicator may flash during startup, indicating that the battery is recharging.

Note: *The alarm function is not active at this time. Refer to Section 8.4 for information about setting the alarms. In addition, for Revco Ultima PLUS units only, the Setpoint Security will be deactivated in this key position.*

8.2 Error Messages

If at any time during startup and operation, an error message appears in the main display, be sure to call Technical Service immediately.

Error messages are of the form “ErXX”. ErX1 indicates incorrect voltage or frequency, and ErX2 through ErX4 indicate sensor failure.

8.3 Setting the Cabinet Temperature

To set the cabinet temperature, complete the following steps:

1. Press and hold the Control Setpoint pad.
2. The Control setpoint LED lights and the Cabinet Temperature LED goes out.
3. Press and hold \triangle to increase the temperature or ∇ to decrease the temperature. The digital display scrolls through temperature settings.
4. Release both pads when the digital temperature display window shows the correct setpoint value.

Note: *If no keys are pressed within ten seconds, the temperature display reverts to the cabinet temperature.*

8.4 Setting the Alarms (Revco Ultima PLUS and Elite PLUS)

On Revco Ultima PLUS and Elite PLUS models, the warm and cold alarms may be set following the instructions below.

To set the cold alarm, complete the following steps:

1. Confirm that the key switch is at the Power On (not the Alarm On) position.
2. Press and hold the Cold Alarm Setpoint pad. The LED next to this pad lights. The temperature display shows the Cold Alarm value.
3. Press and hold \triangle or ∇ to adjust the Cold Alarm Setpoint, which must be 5°C colder than the operating setpoint. When the cabinet temperature setpoint is changed, the alarm setpoints are adjusted automatically to maintain a 5°C difference.
4. Release both pads when the digital temperature display window shows the correct setpoint value.

To set the warm alarm, complete the following steps:

1. Confirm that the key switch is at the Power On (not the Alarm On) position.
2. Press and hold the Warm Alarm Setpoint pad. The LED next to this pad lights. The temperature display shows the Warm Alarm value.
3. Press and hold \triangle or ∇ to adjust the Warm Alarm Setpoint, which must be 5°C warmer than the cabinet temperature setpoint. When the cabinet temperature setpoint is changed, the alarm setpoints are adjusted automatically to maintain a 5°C difference.
4. Release both pads when the digital temperature display window shows the correct setpoint value.

When the cabinet temperature drops below the Warm Alarm setting, turn the key switch to ALARM ON. The freezer is ready to operate.

Note: *If a power failure occurs, the POWER ON light goes out, the POWER FAILURE light and digital temperature display flash simultaneously, and a buzzer sounds if it has not been muted.*



CAUTION! You must turn the three-position key switch to the ALARM ON/SETPOINT SECURITY position to activate the audible alarm and place it in security operation. Remote alarm contacts will work regardless of key position.

8.5 Recording Excursions and Resetting Alarms

8.5.1 Automatic Incident Monitor

The Automatic Incident Monitor records *excursions*, that is extreme warm and cold temperature values.

You can view excursions by simultaneously pressing the Cabinet Temperature and Warm Alarm Setpoint pads for high excursion, and the Cabinet Temperature and Cold Alarm Setpoint pads for low excursion.

IMPORTANT NOTE: *When alarms are activated because of temperature failure, it is advisable to view and record excursions (extreme high and low temperatures) before resetting the alarms. Alarm reset has the effect of resetting excursion values to the current cabinet temperature.*

8.5.2 Alarm Reset

The alarm reset feature, activated by pressing the Alarm Reset pad, ensures user acknowledgment of the occurrence of certain alarm conditions. This provides greater monitoring power by alerting the user if an alarm condition has occurred during periods when the freezer must be left unattended.

The alarm conditions that can be reset are:

- Temperature Failure-Warm Alarm
- Temperature Failure-Cold Alarm
- Power Failure
- Extreme Ambient Alert (Revco Ultima PLUS only)
- Life Guard Alert (Revco Ultima PLUS only)
- Clean Filter

During any of these alarm conditions, the corresponding indicator will flash quickly. If the alarm condition then disappears, the flash rate will decrease. The indicator will then remain flashing at this rate, unless the condition reoccurs, until the Alarm Reset button is pressed. Once the Alarm Reset button has been pressed, the indicator will no longer be lit.

The alarm reset function does not affect the status of remote alarms.

In the case of Temperature Failure-Warm Alarm And Temperature Failure-Cold Alarm, if these conditions have occurred but are now within the given limits, the two indicators will alternately flash (180° out of phase).

Once the Alarm Reset button is pressed, the extreme temperature value is reset to the current cabinet temperature.

8.6 Alarm Test

To test the warm alarm, complete the following steps:

1. Press and hold the Alarm Test pad. The digital temperature display indicates rising temperature. When the temperature reaches the warm alarm value, the audible and visual alarms will be activated, as well as remote alarms, but excursions (extreme temperatures) will not be logged.

Note: *The temperature of the refrigerated space does not change during this procedure.*

2. Release the Alarm Test pad. The display returns to cabinet temperature.

8.7 Program Mode

You can use Program Mode to display and adjust various parameters, including the bracket used for Revco Value PLUS alarm settings.



CAUTION! Do not change the values of Program Mode parameters without consulting Technical Service. Shutdown and/or damage to the freezer could result from improper setting of parameters.

To enter Program Mode, press the Cabinet Temperature pad and hold for 5 seconds. “Prg” will be displayed until you release the pad.

In Program Mode, parameter labels and values are displayed instead of cabinet temperature. The display advances to the next item after a 1.5 second timeout, or when you press the Cabinet Temperature pad.

After 10 seconds of inactivity at any point in the session, Program Mode is deactivated and the cabinet temperature is displayed again.

Table 1. Program Mode Parameters

Parameter	Revco PLUS Models (U=Ultima, E=Elite, V=Value)	Display	Notes
Revision	U, E, V	Displays micro firmware revision in MMmm format.	Display only: “Er06” error if firmware integrity test fails.
Offset	U, E, V	“OFF” then “SET”; followed by offset value.	Offset for calibration: do not adjust without consulting Technical Service. Adjustable using ▲ and ▼. Default value is 0; range is -10°C to 7°C.
Time Delay	U, E, V	“tl” then “dLy;” followed by value.	Value displayed in minutes, in steps of one tenth of a minute. Default is 0.0; range is 0.0 to 20.0. Adjustable using ▲ and ▼. This feature may be used to stagger restart times in case you have multiple freezers.
BUS Type	U, E, V	Displays backup system type only when a backup system is detected.	Display only. Use ▲ and ▼ to toggle between the values “Ln2” and “co2.” Changing this value automatically changes the default setpoint.
BUS Setpoint	U, E, V	Setpoint value in display (only when a backup system is detected).	Adjustable using ▲ and ▼. LN ₂ range is -0°C to -76°C; CO ₂ range is -0°C to -65°C;
Alarm setpoint bracket	V only	Value of alarm bracket (deviation from setpoint) shown in main display.	Use ▲ and ▼ to select value 5, 10, 15, or 20°C. Default value is 10.
Lifeguard	U only	Displays Lifeguard value.	Adjustable using ▲ and ▼. Default value is 94°C; range is 70°C to 98°C.

9 Revco Value PLUS Models – Operation

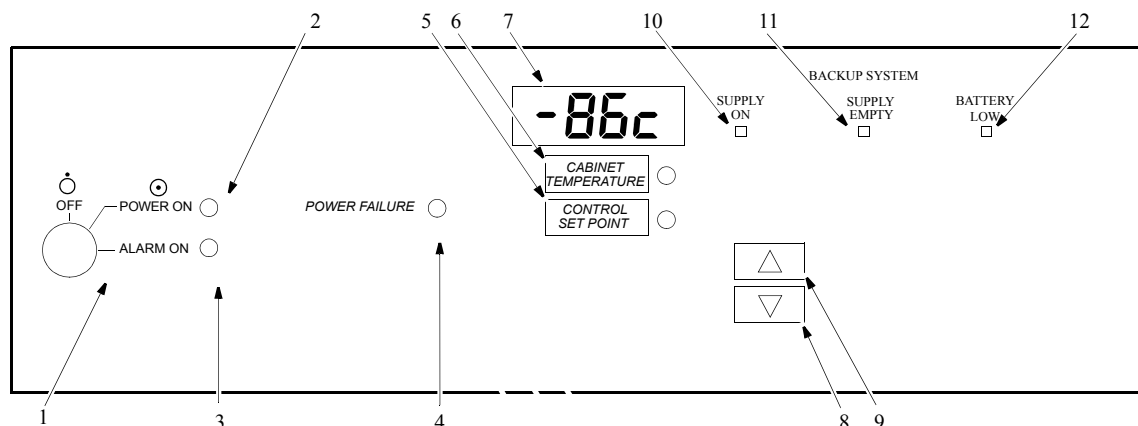

Figure 2. Revco Value PLUS Control Panel with Optional Backup System

9.1 Revco Value PLUS Control Panel

Before the initial start up, take some time to become familiar with the controls on your Revco Value PLUS freezer.

1. Three position keyed Power On Switch.
2. Power On Indicator. This green LED lights when power is connected to the freezer and the key switch is in the ON position.
3. Alarm On Indicator. This indicator lights when the alarm is activated.
4. Power Failure Indicator. This indicator lights when there is a power failure to the freezer.
5. Control Setpoint. Press this pad to set the cabinet temperature.
6. Cabinet Temperature Indicator. Displays cabinet temperature in operating mode, parameters and values when in program mode (refer to Section 8.7 on page 7).
7. Digital Temperature Display Window. This window displays chamber temperature, alarm values, etc. depending on the operating status of the freezer and the procedure being performed.
8. Decrement Pad (∇). Use this pad to decrease temperature values.
9. Increment Pad (\triangle). Use this pad to increase temperature values.

The following indicators are available only when the freezer is equipped with the optional backup system (refer to Section 10.5 on page 10).

10. Backup System Supply On Indicator.
11. Backup System Empty Indicator
12. Backup System Battery Low Indicator.

9.2 Turning the Power On

To start up your freezer, complete the following steps:

1. Plug the freezer into the power outlet.
2. Turn the power switch in back of the freezer, on the bottom right, to the ON position.
3. **If you do not have the CO₂/LN₂ backup option installed**, remove the panel near the lower left corner of the front of the freezer and turn on the Battery Enable switch. Replace the panel.

If you do have the CO₂/LN₂ backup option installed, wait until the freezer has pulled down to operating setpoint before turning on the Battery Enable switch. Refer to Section 10 on page 9 for backup system installation and operation instructions.

4. Turn the key switch to the POWER ON position. The Power On LED and the Cabinet Temperature LED illuminate.

Note: *The alarm function is not active at this time. Refer to Section 9.5 for information about setting the alarms.*

The Low Battery indicator may flash during startup, indicating that the battery is recharging.

9.3 Error Messages

If at any time during startup and operation, an error message appears in the main display, be sure to call Technical Service immediately. Error messages are of the form “ErXX”.

ErX1 indicates incorrect voltage or frequency, and ErX2 and ErX3 indicate sensor failure.

9.4 Setting the Cabinet Temperature

To set the cabinet temperature, complete the following steps:

1. Press and hold the Control Setpoint pad.
2. The Control setpoint LED lights and the Cabinet Temperature LED goes out.
3. Press and hold \triangle to increase the temperature or ∇ to decrease the temperature. The digital display scrolls through temperature settings.
4. Release both pads when the digital temperature display window shows the correct setpoint value.

Note: *If no keys are pressed within ten seconds, the temperature display reverts to the cabinet temperature.*

9.5 Alarm Operation

9.5.1 Setting the Alarms

In RevcoValue PLUS models, the warm and cold alarm setpoints are set automatically with a 10°C bracket. For example, if the operating setpoint is -75°C, the warm and cold alarms will be -65°C and 85°C respectively.

You can change the bracket value in Program Mode, as explained in Section 8.7 on page 7.

9.5.2 Silencing the Alarms

In Revco Value PLUS models, you can silence alarms by turning the key switch to the ON (middle) position.

10 Backup System (Optional)

When you purchase a built-in CO₂ or LN₂ optional backup system for the freezer, backup control is integrated into Program Mode (described in Section 8.7 on page 7).

Note: *Always purchase the cylinders which are equipped with siphon tubes for withdrawing liquid from the bottom of the cylinder. CO₂ cylinders must be kept at room temperature to function properly. LN₂ bottles are functional at any reasonable temperature.*

10.1 CO₂ and LN₂ Precautions

The following are precautions for using liquid CO₂ and LN₂ backup systems.



WARNING! If a CO₂ or LN₂ cylinder falls and a valve is knocked off, the cylinder becomes a deadly and completely unguided missile. Transport the cylinders in a handtruck or cart with secure chain ties for the cylinder. After cylinders are connected to the equipment, securely attach them with chains to a solid, stationary object such as a building column.



WARNING! CO₂ and LN₂ liquids are non-poisonous but are very cold and will burn unprotected skin. Always wear protective eyewear and clothing when changing cylinders or working on the piping systems attached to an active source of liquid refrigerant.



WARNING! The gases produced by evaporation of CO₂ or LN₂ are non-poisonous but displace the oxygen in a confined space and can cause asphyxiation. **Do not store the cylinders in subsurface or enclosed areas.**



CAUTION! When closing the cylinder valve, make sure that the injection solenoid is energized to allow all the liquid to bleed off instead of being trapped in the supply tubing. Failure to do this results in activation of the pressure relief device, which could damage the freezer and requires replacing if it is activated.



CAUTION! For models ordered with factory installed built-in backup systems, the flow of liquid CO₂ or LN₂ will be discontinued if the door is opened during operation of the backup system. For units operated with free-standing, field installed type backup system, the flow of liquid CO₂ or LN₂ will be discontinued upon door opening **only** if the switch provided with the free-standing package is installed on the freezer.

10.2 Installation

Field installed systems are supplied with complete installation and operating instructions. If your system is factory installed, the freezer is shipped with a coiled length of tubing to connect the freezer to the bottles:

- 3/8 in. OD copper tubing for connection to the CO₂ supply.
- 5/8 in. OD copper tubing covered with Armaflex[®] insulating tubing for connection to the LN₂ supply.

Straighten the coiled tubing and connect one end to the labeled connection on the freezer and the other end to the supply bottle or building supply fitting.

10.3 Startup

To activate the backup system;

1. Follow the instructions in Section 8 to power on the freezer and set temperature and alarm setpoints.
2. Enter program mode and check the BUS setpoint value, following the instructions in Section 8.7 on page 7. Adjust this value if necessary.
3. Wait until the cabinet temperature has pulled down to below the BUS setpoint value. ***This is important, because if you turn on the Battery Enable Switch (Step 4) while the cabinet is still warm, you may drain the battery.***
4. When the freezer cabinet temperature is below the BUS setpoint, activate the backup system by turning on the Battery Enable Switch:
 - Remove the panel near the lower left corner of the front of the freezer.
 - Turn on the Battery Enable Switch. Both the power switch and the battery switch must be on for the backup system to operate.
 - Replace the panel.
5. Turn on the CO₂ or LN₂ supply.

10.4 Operation

When the backup system is in operation, you can view and reset parameters in Program Mode (refer to Section 8.7 on page 7).

The backup system can run for a minimum of eight hours on battery power.

10.5 System Status Lights

The built-in backup system includes main control panel system status lights, which appear to the right of the main temperature display as shown in Figure 1 on page 4.

- The Supply On Indicator lights when the backup system is operating on battery power and the system is actively injecting CO₂ or LN₂.
- The Backup System Battery Low Indicator lights when the backup system battery charge is low. The built-in battery charger recharges the battery to full charge when power is restored to the system. Pressing Battery Low displays the battery charge in tenths of a volt, then returns to the main display after about one second.

Note: *Since rechargeable batteries degrade over time, the battery should be replaced after approximately three years or after an event which has required the injection of CO₂ or LN₂.*

- The Backup System Empty Indicator lights when the standby CO₂ or LN₂ bottle is empty.

11 Maintenance and Troubleshooting

Unauthorized repair of your freezer will invalidate your warranty. Contact Technical Service at 1-800-438-4851 for additional information.



CAUTION! Maintenance should only be performed by trained personnel.

11.1 Cleaning the Condenser

Clean the condenser at least every six months; more often if the laboratory area is extremely dust prone.

To clean the condenser, complete the following steps:

1. Pull the grill open.
2. Remove the filter. Check the fans. If a fan is not operating, contact an authorized service company immediately.
3. Vacuum the condenser.
4. Replace the filter and close the grill.

11.2 Cleaning the Condenser Filter

Clean the condenser filter every two or three months.

1. Pull the grill open.
2. Remove the filter.
3. Shake the filter to remove loose dust, rinse the filter in clean water, shake the excess water from the filter, and replace the filter.
4. Close the grill.

11.3 Gasket Maintenance

Periodically check the gaskets around the door for punctures or tears. Leaks are indicated by a streak of frost which forms at the point of gasket failure. Make sure that the cabinet is level (refer to Section 6.3 on page 2 for leveling information).

Keep the door gaskets clean and frost free by wiping gently with a soft cloth.

11.4 Defrosting the Freezer

Defrost the freezer once a year or whenever the ice buildup exceeds 3/8".

To defrost, complete the following steps:

1. Remove all products and place in another cabinet.
2. Turn off the freezer.
3. Open the outer door and all inner doors.
4. Let the freezer stand with doors open for at least 24 hours. This allows both the interior and foamed refrigerant system to warm to room temperature.
5. Dispose of the ice and wipe out any water standing in the bottom of the cabinet.
6. If there is freezer odor, wash the interior with a solution of baking soda and warm water. Clean the exterior with any common household cleaning wax.
7. Close the doors, restart the freezer and reload, following the instructions in Section 4.1 on page 2.

11.5 Alarm Battery Maintenance

Have a certified technician replace the alarm battery after each use, and check the condition of the battery at least once a year.

11.6 Troubleshooting Procedures

Table 2. Troubleshooting Procedures

Problem	Solution
Clean Filter indicator is on.	Condenser filter is dirty. Refer to Section 11.2.
Alarm Battery Low indicator is on.	Alarm battery is low on charge. Have a technician check the alarm battery. Refer to Section 11.5.

12 Chart Recorders

Panel-mounted six-inch seven-day recorders are available as options for all freezer models.

12.1 Set Up and Operation

To prepare the recorder to function properly, complete the following steps:

1. Open the recorder door to access the recorder.
2. Install clean chart paper (refer to Section 12.2 below).
3. Remove the plastic cap from the pen stylus and close the recorder door.

Recorder operation begins when the system is powered on. The recorder may not respond until the system reaches temperatures within the recorder's range.

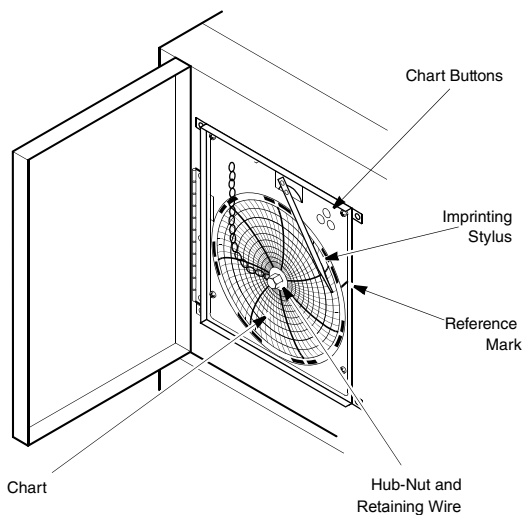

Figure 3. Chart Recorder

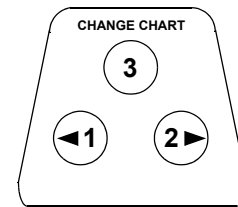

Figure 4. Chart Buttons



CAUTION! Do not use sharp or pointed objects to depress the chart buttons. This may cause permanent damage to the recorder.

12.2 Changing Chart Paper

To change the chart paper, complete the following steps:

1. Locate the pressure sensitive buttons at the front, upper left of the recorder panel.
2. Press and hold the Change Chart button (#3) for one second. The pen will move off the scale.
3. Unscrew the center nut, remove the old chart paper, and install new chart paper. Carefully align the day and time with the reference mark (a small groove on the left side of the recorder panel).
4. Replace the center nut and hand tighten. Press the Change Chart button again to resume temperature recording.

12.3 Calibration Adjustment

This recorder has been accurately calibrated at the factory and retains calibration even during power interruptions. If required, however, adjustments can be made as follows:

1. Run the unit continuously at the control setpoint temperature. Continue steady operation for at least two hours to provide adequate time for recorder response.
2. Measure cabinet center temperature with a calibrated temperature monitor.
3. Compare the recorder temperature to the measured cabinet temperature. If necessary, adjust recorder by pressing the left (#1) and right (#2) chart buttons.

Note: *The stylus does not begin to move until the button is held for five seconds.*

WEEE Compliance

WEEE Compliance. This product is required to comply with the European Union's Waste Electrical & Electronic Equipment (WEEE) Directive 2002/96EC. It is marked with the following symbol. Thermo Fisher Scientific has contracted with one or more recycling/disposal companies in each EU Member State, and this product should be disposed of or recycled through them. Further information on Thermo Fisher Scientific compliance with these Directives, the recyclers in your country, and information on Thermo Scientific products which may assist the detection of substances subject to the RoHS Directive are available at www.thermo.com/

Great Britain



WEEE Konformität. Dieses Produkt muss die EU Waste Electrical & Electronic Equipment (WEEE) Richtlinie 2002/96EC erfüllen. Das Produkt ist durch folgendes Symbol gekennzeichnet. Thermo Fisher Scientific hat Vereinbarungen getroffen mit Verwertungs/Entsorgungsanlagen in allen EU-Mitgliederstaaten und dieses Produkt muss durch diese Firmen verwertet oder entsorgt werden. Mehr Informationen über die Einhaltung dieser Anweisungen durch Thermo Fisher Scientific, die Verwerter und Hinweise die Ihnen nützlich sein können, die Thermo Scientific Produkte zu identifizieren, die unter diese RoHS. Anweisung fallen, finden Sie unter www.thermo.com/

Deutschland



Conformità WEEE. Questo prodotto deve rispondere alla direttiva dell'Unione Europea 2002/96EC in merito ai Rifiuti degli Apparecchi Elettrici ed Elettronici (WEEE). È marcato col seguente simbolo. Thermo Fisher Scientific ha stipulato contratti con una o diverse società di riciclaggio/smaltimento in ognuno degli Stati Membri Europei. Questo prodotto verrà smaltito o riciclato tramite queste medesime. Ulteriori informazioni sulla conformità di Thermo Fisher Scientific con queste Direttive, l'elenco delle ditte di riciclaggio nel Vostro paese e informazioni sui prodotti Thermo Scientific che possono essere utili alla rilevazione di sostanze soggette alla Direttiva RoHS sono disponibili sul sito www.thermo.com/

Italia



Conformité WEEE. Ce produit doit être conforme à la directive européenne (2002/96EC) des Déchets d'Equipements Electriques et Electroniques (DEEE). Il est marqué par le symbole suivant. Thermo Fisher Scientific s'est associé avec une ou plusieurs compagnies de recyclage dans chaque état membre de l'union européenne et ce produit devrait être collecté ou recyclé par celles-ci. Davantage d'informations sur la conformité de Thermo Fisher Scientific à ces directives, les recycleurs dans votre pays et les informations sur les produits Thermo Scientific qui peuvent aider la détection des substances sujettes à la directive RoHS sont disponibles sur www.thermo.com/

France



Important

For your future reference and when contacting the factory, please have the following information readily available:

Model Number: _____

Serial Number: _____

Date Purchased: _____

The above information can be found on the dataplate attached to the equipment. If available, please provide the date purchased, the source of purchase (the manufacturer or specific agent/rep organization), and purchase order number.

IF YOU NEED ASSISTANCE:

SALES DIVISION

Phone: 828/658-2711
800/252-7100

Fax: 828/645-3368

LABORATORY PARTS and SERVICE

Phone: 800/438-4851

Fax: 828/658-2576

TECHNICAL SUPPORT

Phone: 800/438-4851

Thermo Fisher Scientific Inc.

275 Aiken Road
Asheville, NC 28804
United States

www.thermofisher.com

Thermo
SCIENTIFIC

314098H01 Rev. B