

Description

The Model 305 Stimulus Isolator utilizes photon coupling to provide nearly ideal isolation of the pulse and train outputs of the WPI Series 300 Anapulse Stimulators. Two Model 305 units are also used as the output sections of each Model 1880 Dual Stimulus Isolator. The outputs of two units can be combined to produce bipolar and other complex waveforms. The Model 305 has the capability of mixing two inputs on a time (not amplitude) basis, or selecting either one of the two inputs, by means of a selector switch. All 305 units derive their power from dry cell batteries.

NOTE: The Model 305 may be driven from devices other than the WPI Series Anapulse Stimulators or Model 1880. Drive requirements are 4V at 30 mA. Model 305 input connector Pin A is positive with respect to Pin B and Pin C. If any questions arise concerning the input drive requirements or connections, please consult WPI's Engineering Department for assistance.

Specifications

Isolation

Impedance to signal source 10^{11} Ohms, shunted by 2 pF
 Impedance to ground 10^{11} Ohms, shunted by 15 pF

Input

Accepts **Isolator Drive** output from any Series 300 Anapulse Stimulator. Model 305 accepts two inputs and has mixing on a time basis, as well as individual signal selection capability. Model 305 is also driven by Model 1880 **Iso Drive** outputs.

Output

MODE	RANGE x1	RANGE x10	OUTPUT RESISTANCE	RISE TIME
Constant Voltage	0-0.1V	0-1.0V	200 Ohms	2 μ s*
Contant Voltage	0-1.0V	0-10V	2K Ohms	2 μ s*
Constant Voltage	0-10V	0-100V	20K Ohms	2 μ s*
Constant Current	0-5.5 mA	0-5 mA	500 meg Ohms Typical	Load Dependent

**Measured with load resistance = 1 meg Ohm, load capacitance = 150 pF.*

Controls

LEVEL Continuously variable amplitude on all ranges.
 DC Push button switch for manually operated DC output.
 RANGE Rotary switch - 0.1V, 1.0V, 10V, 0.5 mA positions.
 MULTIPLIER x1, x10 Range Multiplier; constant voltage or constant current range selection.
 POLARITY Normal (plus) or inverted (minus) output selection.

Power Requirements

3 batteries:1 each Eveready 246, 9V, or equivalent
 1 each Eveready 455, 45V, or equivalent
 1 each Eveready 467, 67 1/2V or equivalent

Operation

Connect the output terminals (red and black binding posts) to an oscilloscope or DC voltmeter. Turn the level control fully clockwise (maximum). Select the 0.1V range and range multiplier x10. Depress the DC pushbutton and observe the output. A 1 volt DC signal will appear as long as the button is held down. Switch to the 1.0V, x10 and 10V, x10 ranges and repeat. Repeat for all three voltage ranges with the range multiplier in the x1 position. The 0.5 mA, x1, x10 ranges can be checked by connecting the output terminals to DC milliammeter. With the level control set at maximum and range multiplier at x1, a 0.5 mA current will flow as long as the DC button is depressed. With the x10 multiplier, the current flow will be 5 mA.

Check the operation of the Isolator with the Series 300 Anapulse Stimulator or Model 1880 Module. Connect the cable at the rear of the Isolator to the **Isolator Drive** connector on the Series 300 or the **Iso Drive** connector on the 1880.

Note: When the 305 Isolator is used with the 302-T Anapulse unit connect the 305 to the Channel 1 **Isolator Drive** connector. This connector has both CH 1 and CH 2 outputs brought out. Should the 305 be connected to the Channel 2 **Isolator Drive** connector, then 414 on the 305 selector switch corresponds to Anapulse CH 2 output and 424 corresponds to Anapulse CH 1 output.

Set up the Anapulse generator unit or the 1880 pulse generator unit for the desired pulse time parameters. Observe the output of the Isolator on an oscilloscope. The pulse amplitudes can be varied by the level control, from zero to the maximum value of the selected range and range multiplier.

Model 305 Channel Selector Switches

The two switches allow the selection of either CH 1 or CH 2 pulses ON or both ON or both OFF. The mixing should be done on a time basis, not amplitude, since the Isolator is not intended to have the capability of adding pulse amplitudes by means of the Channel Selector switches.

Polarity

A polarity switch is provided. When the NORM position is selected, the red binding post is positive with respect to the black binding post. In the INVERT position the polarity is reversed.

Constant Current Operation

A convenient way of setting the current level when operating in the constant current mode is to make the setting in a voltage range. Using the 1.0V range, x10 multiplier, each volt of output is equal to 0.5 mA. Set up a voltage equivalent to the desired current, then switch to the current range, keeping in mind that the full scale current is 0.5 mA full scale. Should it be desired to use the lower current range

(0.5 mA full scale, x1 multiplier), however, each volt of output is now equal to 0.05 mA. Set up the voltage equivalent to the desired current, then switch the multiplier to x1 and the selector to the current range.

The current will remain constant independent of the external load resistance, as long as the voltage across the load does not exceed 100 volts. Figure 1 shows the operating zones, based on load current versus load resistance for the x1 and x10 current ranges. On the x1 range the full 0.5 mA is available for load resistances of 200K Ohms or less. On the x10 range the full 5 mA is available for load resistances of 20K Ohms or less.

Low Level Current Stimulation

Low level stimulation (nanoampere range) can be done by using the appropriate voltage range and inserting a 10 meg Ohm or larger resistance in series with the stimulating electrode. The high resistance in series with the electrode effectively makes the output a constant current. The current range for the .1V, x1 multiplier range with a 10 meg Ohm series resistor is 0-10 nanoamperes.

$$\frac{0.1 \text{ volts}}{10^7 \text{ ohms}} = 10^{-8} \text{ amperes}$$

The series resistance used should be at least 100 times the electrode resistance.

Chassis Connector

The green binding post labelled CHASS is connected to the internal chassis of the unit. This terminal provides a guarding feature useful in some biological applications. If an electrode connected to this terminal is interposed between the stimulating electrodes, capacitive currents which would normally flow to ground should be reduced and less stimulus artifact should be observed. This technique may not be necessary in many experimental situations, since some artifact is desirable to mark the recording at the instant the stimulus is applied.

Figure 2—Series Connection (Voltage Mode)

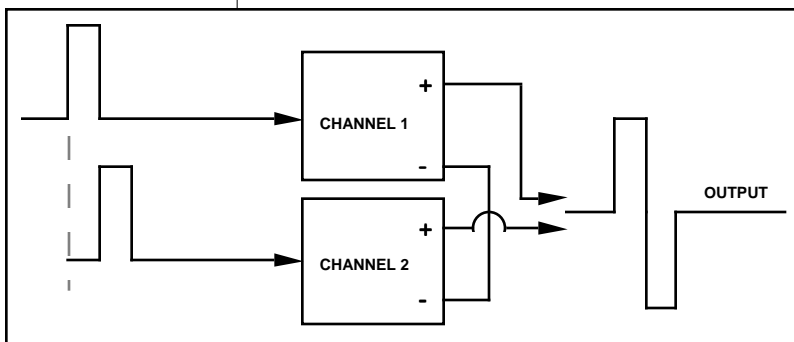

Two or more isolator outputs can be combined either in series (voltage mode) or parallel (current mode). This may be done to obtain larger voltages or currents than available from a single channel. Bipolar and other complex waveforms are possible also. An example of a series connection for bipolar operation is shown in Figure 2.

These simple rules should be observed. IN THE VOLTAGE

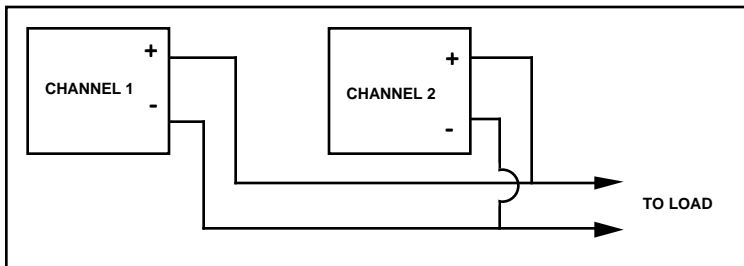

MODE, UNITS ARE OPERATED IN TANDEM (SERIES). IN THE CURRENT MODE, UNITS ARE OPERATED IN SHUNT (PARALLEL). An example of current mode shunt operation of two isolation modules is shown in Figure 3.

Figure 3—
Parallel
Connection
(Current Mode)

WARNING: DO NOT OPERATE THE SERIES 305 STIMULUS ISOLATOR WITH AN INDUCTIVE LOAD AT HIGH CURRENT. POSSIBLE DESTRUCTION OF THE OUTPUT STAGE MAY RESULT.

Maintenance

Battery Replacement

The Model 305 Series Stimulus Isolator uses three (3) batteries:

- 1 each Eveready 246, 9V or equivalent
- 1 each Eveready 455, 45V or equivalent
- 1 each Eveready 467, 67 1/2V or equivalent

A simple test to determine if the batteries need replacing is to:

1. Connect the red (plus) and black (minus) output terminals to a DC voltmeter or oscilloscope.
2. Set the output selector to the 0-10V, x10 multiplier range, and depress the DC push button. If the output falls below 100 volts, the batteries should be replaced.
3. Remove the four screws on the sides of the case. These screws are located at the rear of the unit. Slide out the battery holding assembly from the rear of the unit. This assembly is attached to the rear panel. Replace batteries in the same position as they are different voltages and reassemble the unit.

Note: Batteries which measure low in the 100V range will not affect operation if the full output of 100V is not required. Under normal use, the batteries should last for several months. When the instrument is unused for a long period, remove batteries to avoid damage from corrosion. To check operation of the unit refer to the section on Operation.

Warranty

WPI (World Precision Instruments, Inc.) warrants to the original purchaser that this equipment, including its components and parts, shall be free from defects in material and workmanship for a period of one year* from the date of shipment. WPI's obligation under this warranty shall be limited to repair or replacement, at WPI's option, of the equipment or defective components or parts upon receipt thereof f.o.b. WPI, Sarasota, Florida U.S.A. Return of a repaired instrument shall be f.o.b. Sarasota.

The above warranty is contingent upon normal usage and does not cover products which have been modified without WPI's approval or which have been subjected to unusual physical or electrical stress or on which the original identification marks have been removed or altered. The above warranty will not apply if adjustment, repair or parts replacement is required because of accident, neglect, misuse, failure of electric power, air conditioning, humidity control, transportation, or causes other than normal and ordinary usage.

To the extent that any of its equipment is furnished by a manufacturer other than WPI, the foregoing warranty shall be applicable only to the extent of the warranty furnished by such other manufacturer. This warranty will not apply to appearance terms, such as knobs, handles, dials or the like.

The foregoing obligations set forth in this paragraph are in lieu of all obligations and liabilities, including all warranties of merchantability or otherwise, expressed or implied or statutory, and state WPI's entire and exclusive liability and purchaser's exclusive remedy for any claim of damages in connection with the sale or furnishing of all equipment, including design, suitability for use, operation, or installation. There are no warranties which extend beyond the description of the face hereof. In no event shall WPI be liable for any special or consequential damages.

Warning: This equipment is not designed or intended for use on humans.

** Electrodes, batteries and other consumable parts are warranted for 30 days only from the date on which the customer receives these items.*



INSTRUCTION MANUAL

Serial No. _____

04E

World Precision Instruments, Inc.

International Trade Center, 175 Sarasota Center Boulevard, Sarasota FL 34240-9258 USA

Telephone: 941-371-1003 • Fax: 941-377-5428 • E-mail: wpi@wpiinc.com

UK: Astonbury Farm Business Centre, Astonbury, Stevenage, Hertfordshire SG2 7EG England • Tel: 0438-880025 • Fax: 0438-880026

Germany: Liegnitzer Str. 15, D-10999 Berlin, Germany • Tel: 030-6188845 • Fax: 030-6188670

Japan: 1-4-2 Naka-Meguro, Meguro, Tokyo 153, Japan • Tel: 03-3220-5200 • Fax: 03-3220-5201