

MX1100L

5-axis precision micromanipulator instructions

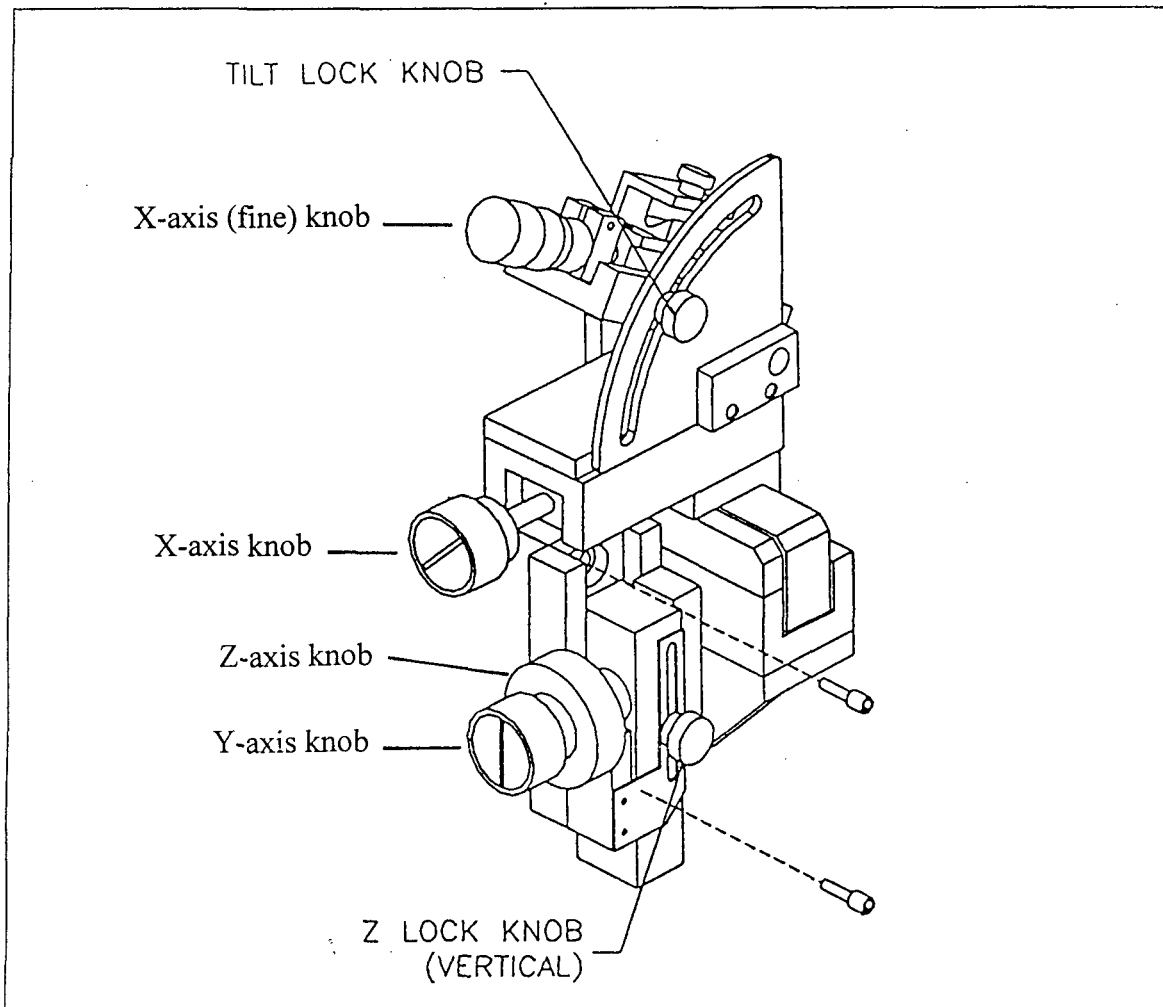

1. Before operating Z-axis (vertical axis), please make sure that Z-axis lock is loosened.
2. Cover manipulator when not in use to prevent dust from entering bearings.

For technical assistance, please contact Dr. Pat Wong. Tel: (949) 854-0220,
email: soma@somascientific.com.

SOMA SCIENTIFIC INSTRUMENTS, INC.

5319 University Drive, #366, Irvine, CA 92612

Tel: (949) 854-0220 Fax: (949) 854-0223