

INA101

MILITARY & DIE
VERSIONS
AVAILABLE

Very-High Accuracy INSTRUMENTATION AMPLIFIER

FEATURES

- ULTRA-LOW VOLTAGE DRIFT - $0.25 \mu\text{V}/^\circ\text{C}$
- LOW OFFSET VOLTAGE - $25 \mu\text{V}$
- LOW NONLINEARITY - 0.002%
- LOW NOISE - $13 \text{ nV}/\sqrt{\text{Hz}}$ at $f_0 = 1 \text{ kHz}$
- HIGH CMR - 106 dB at 60 Hz
- HIGH INPUT IMPEDANCE - $10^{10} \Omega$
- LOW COST, TO-100, CERAMIC DIP AND PLASTIC PACKAGE

APPLICATIONS

- AMPLIFICATION OF SIGNALS FROM SOURCES SUCH AS:
Strain Gages
Thermocouples
RTDs
- REMOTE TRANSDUCERS
- LOW LEVEL SIGNALS
- MEDICAL INSTRUMENTATION

DESCRIPTION

The INA101 is a high accuracy, multistage, integrated-circuit instrumentation amplifier designed for signal conditioning requirements where very-high performance is desired. All circuits, including the interconnected laser-trimmed thin-film resistors, are integrated on a single monolithic substrate.

A multi-amplifier design is used to provide the highest performance and maximum versatility with monolithic construction for low cost. The input stage uses Burr-Brown's ultra-low drift, low noise technology to provide exceptional input characteristics.

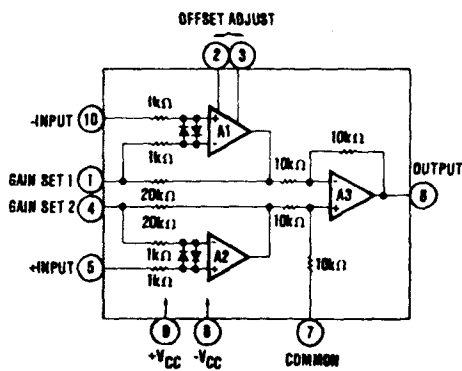

M Package

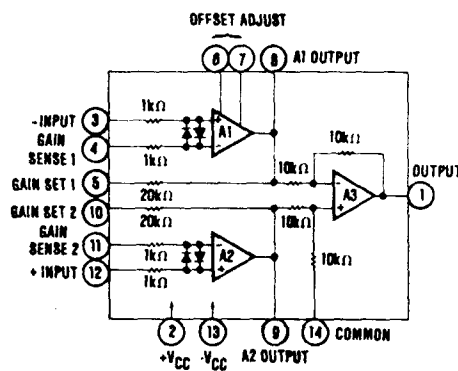

G and P Packages

International Airport Industrial Park - P.O. Box 11400 - Tucson, Arizona 85734 - Tel. (602) 746-1111 - Tlx: 910-952-1111 - Cable: BBRCORP - Telex: 66-6491

PDS-454H

INA101

3

INSTRUMENTATION AMPLIFIERS

SPECIFICATIONS

ELECTRICAL

At +25°C with ±15VDC power supply and in circuit of Figure 2 unless otherwise noted

MODEL	INA101AM/AG			INA101BM/BG			INA101CM/CG			INA101PM/KU			UNITS
	MIN	TYP	MAX	MIN	TYP	MAX	MIN	TYP	MAX	MIN	TYP	MAX	
GAIN													
Range of Gain	1		1000	*	*	*	*	*	*	*	*	*	V/V
Gain Equation		$G = 1 + (40k/R_G)$											V/V
Error From Equation, DC ⁽¹⁾		$\pm(0.04 + 0.00016G - 0.02/G)$	$\pm(0.1 + 0.0003G - 0.05/G)$								$\pm(0.3 - 0.0002G) - 0.10/G$		%
Gain Temp Coefficient⁽²⁾													ppm/°C
G = 1		2	5										ppm/°C
G = 10		20	100					10					ppm/°C
G = 100		22	110					11					ppm/°C
G = 1000		22	110					11					ppm/°C
Nonlinearity, DC ⁽³⁾		$\pm(0.002 + 10^{-5}G)$	$\pm(0.005 + 2 \cdot 10^{-5}G)$		$\pm(0.001 - 10^{-5}G)$	$\pm(0.002 - 10^{-5}G)$		$\pm(0.001 - 10^{-5}G)$	$-10.002 - 10^{-5}G$				% of p-p FS
RATED OUTPUT													
Voltage	±10	±12.5		*	*	*	*	*	*	*	*	*	V
Current	±5	±10		*	*	*	*	*	*	*	*	*	mA
Output Impedance		0.2		*	*	*	*	*	*	*	*	*	Ω
Capacitive Load		1000		*	*	*	*	*	*	*	*	*	pF
INPUT OFFSET VOLTAGE													
Initial Offset at +25°C		±(25+200/G)	±(50+400/G)		±(10-100/G)	±(25-200/G)		±(10+100/G)	-25-200/G		±(125+450/G)	-(250-900/G)	μV
vs Temperature			±(2+20/G)			±(1+20/G)			-10/75-10/G		±(2+20/G)		μV/°C
vs Supply		±(1+20/G)											μV/V
vs Time		±(1+20/G)											μV/ms
INPUT BIAS CURRENT													
Initial Bias Current (each input)		±15	±30		±10	*		±5	±20		*	*	nA
vs Temperature		-0.2			*			*			*	*	nA/°C
vs Supply		-0.1			*			*			*	*	nA/V
Initial Offset Current		±15	±30		±10	*		±5	±20		*	*	nA
vs Temperature		-0.5			*			*			*	*	nA/°C
INPUT IMPEDANCE													
Differential		10 ¹⁰ Ω			*	*		*	*		*	*	Ω
Common-mode		10 ⁹ Ω			*	*		*	*		*	*	pF
INPUT VOLTAGE RANGE													
Range, Linear Response	±10	±12		*	*	*	*	*	*	*	*	*	V
CMR with 1kΩ Source Imbal.				*	*	*	*	*	*	*	*	*	
DC to 60Hz, G=1	80	90		*	*	*	*	*	65	85	85	85	dB
DC to 60Hz, G=10	96	106		*	*	*	*	*	90	95	95	95	dB
DC to 60Hz, G=100 to 1000	106	110		*	*	*	*	*	100	106	106	106	dB
INPUT NOISE													
Input Voltage Noise		0.8			*	*		*	*		*	*	μV, p-p
$f_b = 0.01\text{Hz to } 10\text{Hz}$					*	*		*	*		*	*	
Density, G=1000					*	*		*	*		*	*	nV/√Hz
$f_b = 10\text{Hz}$		18			*	*		*	*		*	*	nV/√Hz
$f_b = 100\text{Hz}$		15			*	*		*	*		*	*	nV/√Hz
$f_b = 1\text{kHz}$		13			*	*		*	*		*	*	nV/√Hz
Input Current Noise		50			*	*		*	*		*	*	pA, p-p
$f_b = 0.01\text{Hz to } 10\text{Hz}$					*	*		*	*		*	*	
Density					*	*		*	*		*	*	pA/√Hz
$f_b = 10\text{Hz}$		0.9			*	*		*	*		*	*	pA/√Hz
$f_b = 100\text{Hz}$		0.46			*	*		*	*		*	*	pA/√Hz
$f_b = 1\text{kHz}$		0.35			*	*		*	*		*	*	pA/√Hz
DYNAMIC RESPONSE													
Small Signal, ±3dB Flatness					*	*		*	*		*	*	kHz
G = 1		300			*	*		*	*		*	*	kHz
G = 10		140			*	*		*	*		*	*	kHz
G = 100		25			*	*		*	*		*	*	kHz
G = 1000		2.5			*	*		*	*		*	*	kHz
Small Signal, ±1% Flatness					*	*		*	*		*	*	kHz
G = 1		20			*	*		*	*		*	*	kHz
G = 10		10			*	*		*	*		*	*	kHz
G = 100		1			*	*		*	*		*	*	kHz
G = 1000		200			*	*		*	*		*	*	Hz
Full Power, G=1 to 100		6.4			*	*		*	*		*	*	Hz
Slew Rate, G=1 to 100	0.2	0.4		*	*	*	*	*	*	*	*	*	V/μs
Setting Time (0.1%)					*	*		*	*		*	*	μs
G = 1		30	40		*	*		*	*		*	*	μs
G = 100		40	55		*	*		*	*		*	*	μs
G = 1000		350	470		*	*		*	*		*	*	μs
Setting Time (0.01%)					*	*		*	*		*	*	μs
G = 1		30	45		*	*		*	*		*	*	μs
G = 100		50	70		*	*		*	*		*	*	μs
G = 1000		500	650		*	*		*	*		*	*	μs
POWER SUPPLY													
Rated Voltage		±15		*	*	*	*	*	*	*	*	*	V
Voltage Range			±20	*	*	*	*	*	*	*	*	*	V
Current, Quiescent ⁽⁴⁾		±6.7	±8.5	*	*	*	*	*	*	*	*	*	mA
TEMPERATURE RANGE⁽⁵⁾													
Specification	-25		+85	-55		+125				0	-70		°C
Operation	-55		+125	*	*	*	*	*	*	-25	-85		°C
Storage	-65		+150	*	*	*	*	*	*	-40	-85		°C

* Specifications same as for INA101AM/AG.

NOTES: (1) Typically the tolerance of R_G will be the major source of gain error. (2) Nonlinearity is the maximum peak deviation from the best straight-line as a percentage of peak-to-peak full scale output. (3) Not including the TCR of R_G . (4) Adjustable to zero at any one gain. (5) θ_{zc} output stage = 113°C/W, θ_{zc} quiescent circuitry = 19°C/W, $\theta_{ca} = 83°C/W$.

MECHA



PIN C

OFF AD. OF AC

MECHANICAL

M Package

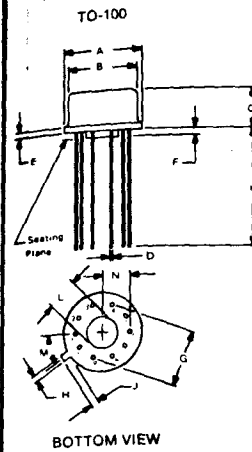

Case = -V_{cc}
 Leads in true position within 0.010" (0.25mm) R at MMC at seating plane
 Pin numbers shown for reference only.
 Numbers may not be marked on package

DIM	INCHES		MILLIMETERS	
	MIN	MAX	MIN	MAX
A	.335	.370	8.51	9.40
B	.305	.325	7.75	8.51
C	.185	.185	4.79	4.70
D	.016	.021	0.41	0.53
E	.010	.040	0.25	1.02
F	.010	.040	0.25	1.02
G	230 BASIC		5.84 BASIC	
H	.028	.034	0.71	0.86
J	.029	.045	0.74	1.14
K	500		12.70	
L	.120	.160	3.05	4.06
M	36° BASIC		36° BASIC	
N	.110	.120	2.79	3.05

G Package

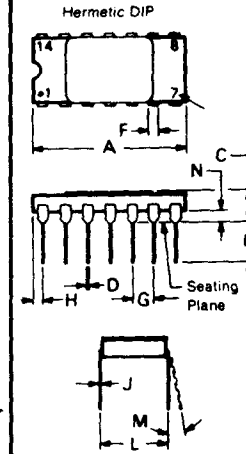

Leads in true position within 0.01" (0.25mm) R at MMC at seating plane
 Pin numbers shown for reference only. Numbers may not be marked on package

DIM	INCHES		MILLIMETERS	
	MIN	MAX	MIN	MAX
A	.670	.710	17.02	18.03
C	.085	.110	1.65	4.32
D	.015	.021	0.38	0.53
E	.045	.060	1.14	1.52
G	100 BASIC		2.54 BASIC	
H	.026	.070	0.64	1.78
J	.008	.012	0.20	0.30
K	.120	.240	3.05	6.10
L	300 BASIC		7.62 BASIC	
M	10°		10°	
N	.008	.060	0.23	1.52

U Package

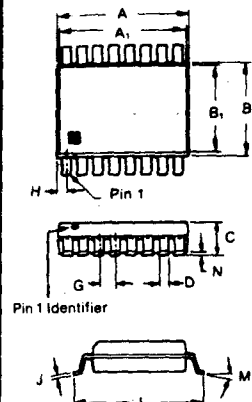

NOTE: Leads in true position within 0.10" (2.5mm) R at MMC at seating plane.
 Pin numbers shown for reference only. Numbers are not marked on package.

DIM	INCHES		MILLIMETERS	
	MIN	MAX	MIN	MAX
A	.400	.418	10.16	10.57
A ₁	.388	.412	9.86	10.46
B	.286	.302	7.26	7.67
B ₁	.268	.286	6.81	7.26
C	.083	.109	2.36	2.77
D	.015	.020	0.38	0.51
G	060 BASIC		1.27 BASIC	
H	.022	.038	0.56	0.97
J	.008	.012	0.20	0.30
L	.391	.421	9.93	10.69
M	5° TYP		5° TYP	
N	.000	.012	0.00	0.30

P Package

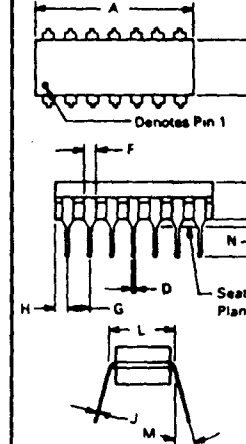

Case = -V_{cc}
 Leads in true position within 0.10" (0.25mm) R at MMC at seating plane
 Pin numbers shown for reference only. Numbers may not be marked on package

DIM	INCHES		MILLIMETERS	
	MIN	MAX	MIN	MAX
A	.880	.985	22.38	25.04
B	.220	.280	5.59	7.11
C	.300		7.62	
D	.015	.021	0.38	0.53
F	.030	.070	0.76	1.78
G	100 BASIC		2.54 BASIC	
H	.030	.095	0.76	2.41
J	.008	.015	0.20	0.38
K	100		2.54	
L	300 BASIC		7.62 BASIC	
M	15°		15°	
N	.020	.050	0.51	1.27

PIN CONFIGURATION

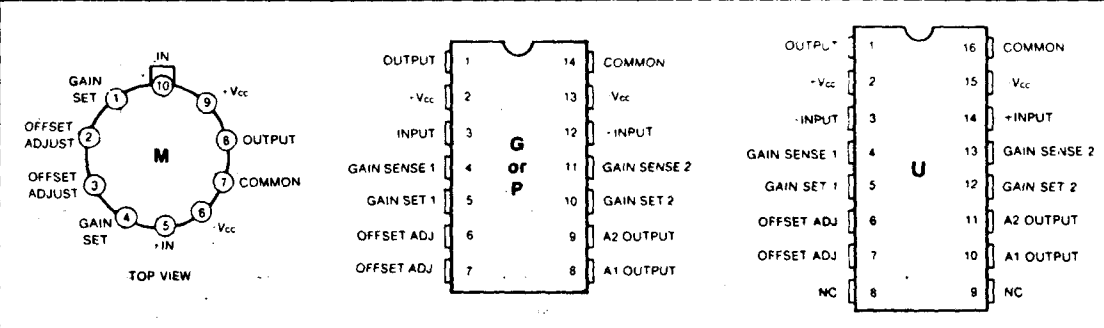

HP/KU	MAX	UNITS
±(0.3-0.0002G)		V/V
-0.10/G		%
		ppm/°C
		ppm/°C
		ppm/°C
		% of p-p FS
		V
		mA
		Ω
		PF
±(250-900/G)		μV
		μV/°C
		μV/V
		μV/mV
		nA
		nA/°C
		nA/V
		nA/°C
		Ω, PF
		Ω, PF
		V
		Ω
		Ω
		Ω
		μV, p-p
		nV/√Hz
		nV/√Hz
		nV/√Hz
		pA, p-p
		pA/√Hz
		pA/√Hz
		pA/√Hz
		kHz
		kHz
		kHz
		kHz
		Hz
		Hz
		V/μm
		μs
		μs
		μs
		V
		V
		mA
-70		°C
+85		°C
+85		°C

straight-line as a percentage of quiescent current
 circuitry = 19°C/W

ORDERING INFORMATION

Model	Package	Temperature Range
INA101AG	Ceramic DIP	-25°C to +85°C
INA101CG	Ceramic DIP	-25°C to +85°C
INA101AM	Metal TO-100	-25°C to +85°C
INA101CM	Metal TO-100	-25°C to +85°C
INA101HP	Plastic DIP	0°C to +70°C
INA101KU	Plastic SOIC	0°C to +70°C
INA101SG	Ceramic DIP	-55°C to +125°C
INA101SM	Metal TO-100	-55°C to +125°C

BURN-IN SCREENING OPTION		
See text for details.		
Model	Package	Burn-In Temp. (160h) ⁽¹⁾
INA101AG-BI	Ceramic DIP	+125°C
INA101CG-BI	Ceramic DIP	+125°C
INA101AM-BI	Metal TO-100	+125°C
INA101CM-BI	Metal TO-100	+125°C
INA101HP-BI	Plastic DIP	+85°C
INA101KU-BI	Plastic SOIC	+85°C
INA101SG-BI	Ceramic DIP	+125°C
INA101SM-BI	Metal TO-100	+125°C

NOTE: (1) Or equivalent combination. See text.

ABSOLUTE MAXIMUM RATINGS

Supply	±20V
Internal Power Dissipation	600mW
Input Voltage Range	±V _{CC}
Operating Temperature Range M, G	-55°C to +125°C
P, U	-25°C to +85°C
Storage Temperature Range: M, G	-65°C to +150°C
P, U	-40°C to +85°C
Lead Temperature (soldering, 10s) M, G, P	+300°C
Lead Temperature (wave soldering, 3s) U	+260°C
Output Short-Circuit Duration	Continuous to ground

BURN-IN SCREENING

Burn-in screening is an option available for both the plastic- and ceramic-packaged INA101. Burn-in duration is 160 hours at the temperature shown below (or equivalent combination of time and temperature).

Plastic "-BI" models: +85°C

Ceramic "-BI" models: +125°C

All units are tested after burn-in to ensure that grade specifications are met. To order burn-in, add "-BI" to the base model number.

TYPICAL PERFORMANCE CURVES

At +25°C and in circuit of Figure 2 unless otherwise noted.

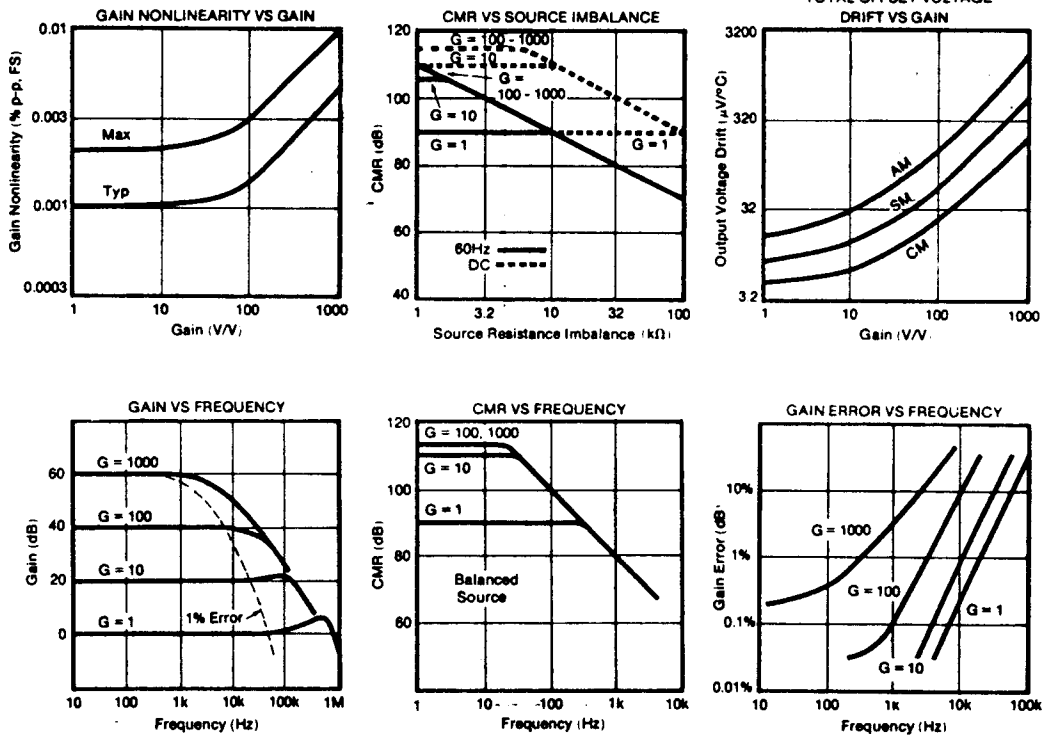

±20V
600mW
±V _{OC}
-55°C to +125°C
-25°C to +85°C
-85°C to +150°C
-40°C to +85°C
+300°C
+280°C
Continuous to ground

available for both the
 01. Burn-in duration
 shown below (or
 temperature).

to ensure that grade
 n-in, add "-BI" to the

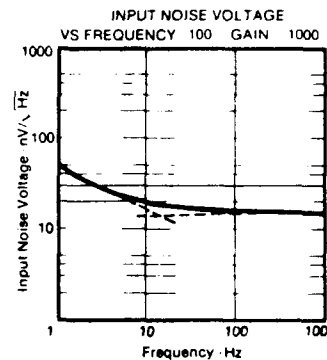
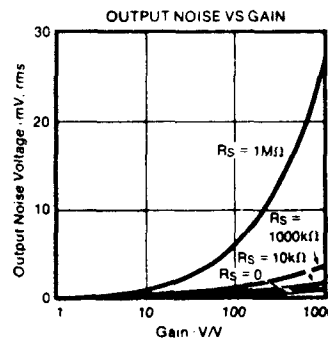
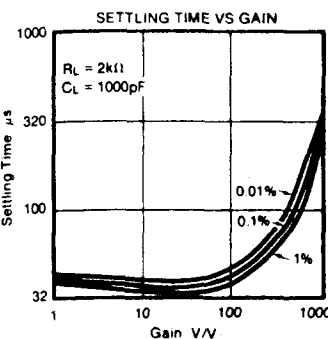
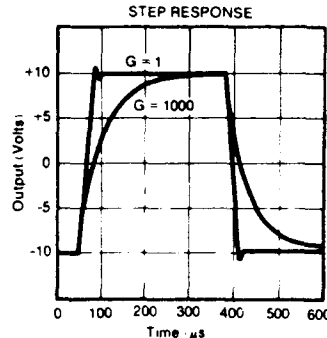
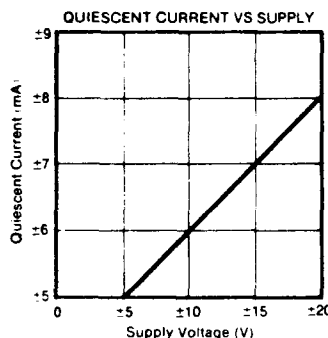
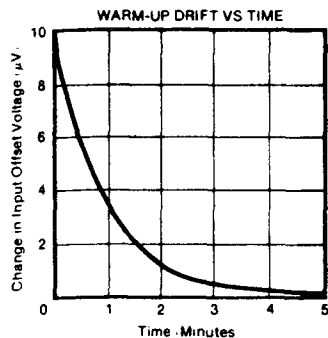
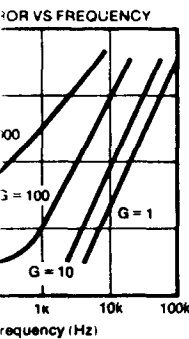
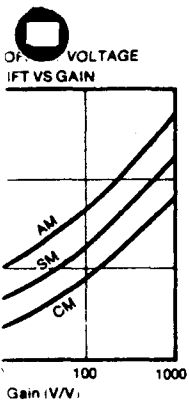

DISCUSSION OF PERFORMANCE

INSTRUMENTATION AMPLIFIERS

Instrumentation amplifiers are differential input closed-loop gain blocks whose committed circuit accurately amplifies the voltage applied to their inputs. They respond only to the difference between the two input signals and exhibit extremely-high input impedance, both differentially and common-mode. Feedback networks are packaged within the amplifier module. Only one external gain setting resistor must be added. An operational amplifier, on the other hand, is an open-loop,

uncommitted device that requires external networks to close the loop. While op amps can be used to achieve the same basic function as instrumentation amplifiers, it is very difficult to reach the same level of performance. Using op amps often leads to design trade-offs when it is necessary to amplify low level signals in the presence of common-mode voltages while maintaining high input impedances. Figure 1 shows a simplified model of an instrumentation amplifier that eliminates most of the problems.

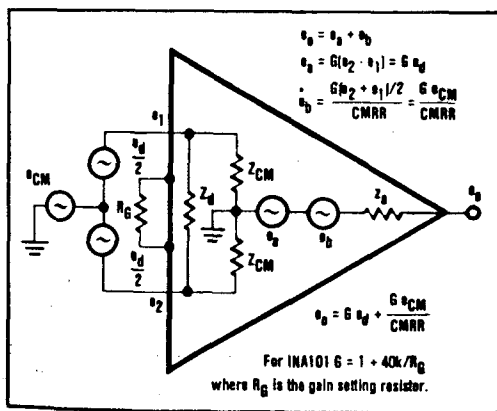

FIGURE 1. Model of an Instrumentation Amplifier.

THE INA101

Simplified schematics of the INA101 are shown on the first page. It is a three-amplifier device which provides all the desirable characteristics of a premium performance instrumentation amplifier. In addition, it has features not normally found in integrated circuit instrumentation amplifiers.

The input section (A1 and A2) incorporates high performance, low drift amplifier circuitry. The amplifiers are connected in the noninverting configuration to provide the high input impedance ($10^{10} \Omega$) desirable in the instrumentation amplifier function. The offset voltage and offset voltage versus temperature is low due to the monolithic design and improved even further by the state-of-the-art laser-trimming techniques.

The output section (A3) is connected in a unity-gain difference amplifier configuration. A critical part of this stage is the matching of the four 10kΩ resistors which provide the difference function. These resistors must be initially well matched and the matching must be maintained over temperature and time in order to retain excellent common-mode rejection. (The 106dB minimum at 60Hz for gains greater than 100V/V is a significant improvement compared to most other integrated circuit instrumentation amplifiers.)

All of the internal resistors are compatible thin-film nichrome formed with the integrated circuit. The critical resistors are laser-trimmed to provide the desired high gain accuracy and common-mode rejection. Nichrome ensures long-term stability of trimmed resistors and simultaneous achievement of excellent TCR and TCR tracking. This provides gain accuracy and common-mode rejection when the INA101 is operated over wide temperature ranges.

USING THE INA101

Figure 2 shows the simplest configuration of the INA101. The gain is set by the external resistor, R_G , with a gain equation of $G = 1 + (40k / R_G)$. The reference and TCR of R_G contribute directly to the gain accuracy and drift.

For gains greater than unity, resistor R_G is connected externally between pins 1 and 4. At high gains where the value of R_G becomes small, additional resistance (i.e.,

relays, sockets) in the R_G circuit will contribute to a gain error. Care should be taken to minimize this effect.

The optional offset null capability is shown in Figure 2. The adjustment affects only the input stage component of the offset voltage. Thus, the null condition will be disturbed when the gain is changed. Also, the input drift will be affected by approximately $0.31 \mu V / ^\circ C$ per $100 \mu V$ of input offset voltage that is trimmed. Therefore, care should be taken when considering use of the control for removal of other sources of offset. Output offsetting can be accomplished in Figure 3 by applying a voltage to Common (pin 7) through a buffer amplifier. This limits the resistance in series with pin 7 to minimize CMR error. Resistance above 0.1Ω will cause the common-mode rejection to fall below 106dB. Be certain to keep this resistance low.

It is important to not exceed the input amplifiers' dynamic range. The amplified differential input signal and its associated common-mode voltage should not cause the output of A_1 or A_2 to exceed approximately $\pm 10V$ or nonlinear operation will result.

BASIC CIRCUIT CONNECTION

The basic circuit connection for the INA101 is shown in Figure 2. The output voltage is a function of the differential input voltage times the gain.

OPTIONAL OFFSET ADJUSTMENT PROCEDURE

It is frequently desirable to null the input component of offset (Figure 2) and occasionally that of the output (Figure 3). The quality of the potentiometer will affect the results, therefore, choose one with good temperature and mechanical-resistance stability. The procedure is as follows:

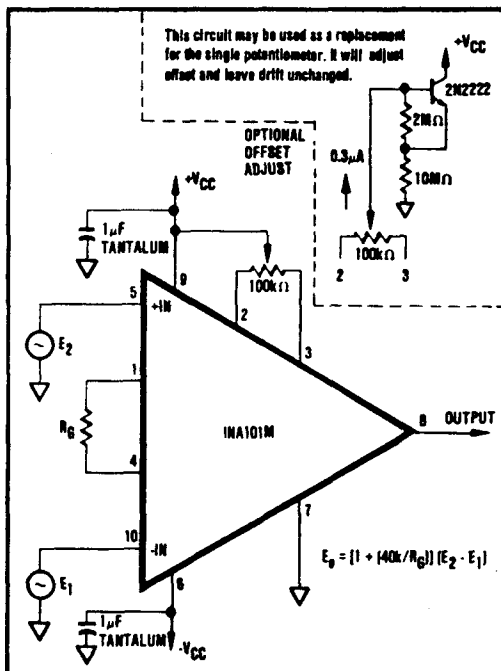

FIGURE 2. Basic Circuit Connection for the INA101 Including Optional Input Offset Null Potentiometer.

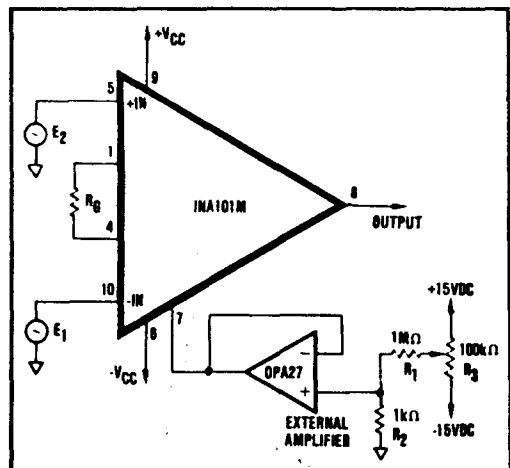

FIGURE 3. Optional Output Offset Nulling or Offsetting Using External Amplifier (Low Impedance to Pin 7).

It will contribute to a gain error. To minimize this effect.

ity is shown in Figure 2. The input stage component of the input stage component of the null condition will be affected. Also, the input drift is only $0.31 \mu\text{V}/^\circ\text{C}$ per $100 \mu\text{V}$ trimmed. Therefore, careful use of the control for offset. Output offsetting can be achieved by applying a voltage to the offset amplifier. This limits the common-mode error. Be certain to keep this

the input amplifiers' differential input signal. The offset voltage should not exceed approximately the result.

IN the INA101 is shown in Figure 3 as a function of the gain.

MENT PROCEDURE The input component of the output will affect the good temperature and the procedure is as

1. Set $E_1 = E_2 = 0\text{V}$ (be sure a good ground return path exists to the input).
2. Set the gain to the desired value by choosing R_G .
3. Adjust to $100\text{k}\Omega$ potentiometer in Figure 2 until the output reads $0\text{V} \pm 1\text{mV}$ or desired setting. Note that the offset will change when the gain is changed. If the output component of offset is to be removed or if it is desired to establish an intentional offset, adjust the $100\text{k}\Omega$ potentiometer in Figure 3 until the output reads $0\text{V} \pm 1\text{mV}$ or desired setting. Note that the offset will not change with gain, but be sure to use a stable external amplifier with good DC characteristics. The range of adjustment is $\pm 15\text{mV}$ as shown. For larger ranges change the ratio of R_1 to R_2 .

THERMAL EFFECTS ON OFFSET

To maintain specified offset performance, especially in high gain, prevent air currents from circulating around the input pins. This can be done by using a skirted heat

sink on the INA101M package. Rapid changes in die temperature and thermocouple effects on the pins will then be minimized. Surrounding the package with low power components will also help to reduce air flow across the package and pins.

TYPICAL APPLICATIONS

Many applications of instrumentation amplifiers involve the amplification of low level differential signals from bridges and transducers such as strain gages, thermocouples, and RTD's. Some of the important parameters include common-mode rejection (differential cancellation of common-mode offset and noise, see Figure 1), input impedance, offset voltage and drift, gain accuracy, linearity, and noise. The INA101 accomplishes all of these with high precision.

Figures 4 through 16 show some typical applications circuits.

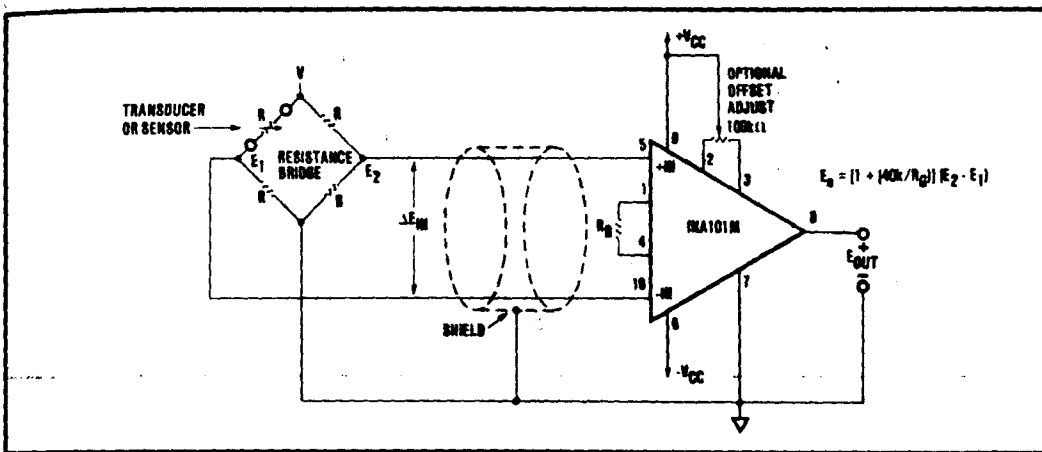

FIGURE 4. Amplification of a Differential Voltage from a Resistance Bridge.

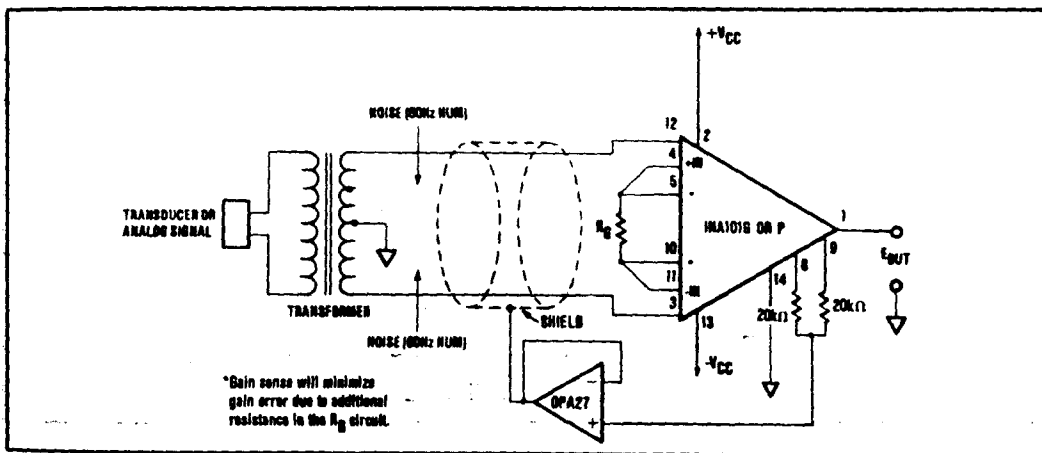
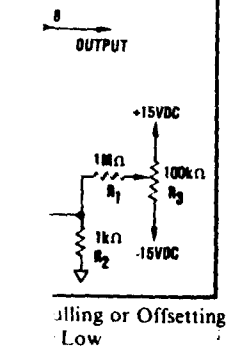

FIGURE 5. Amplification of a Transformer-Coupled Analog Signal.



Offsetting or Offsetting Low

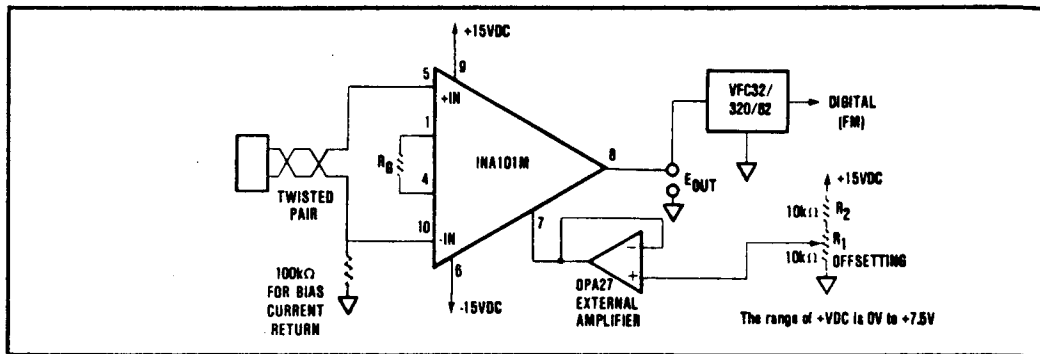

FIGURE 6. Output Offsetting Used to Introduce a DC Voltage for Use with a Voltage-to-Frequency Converter.

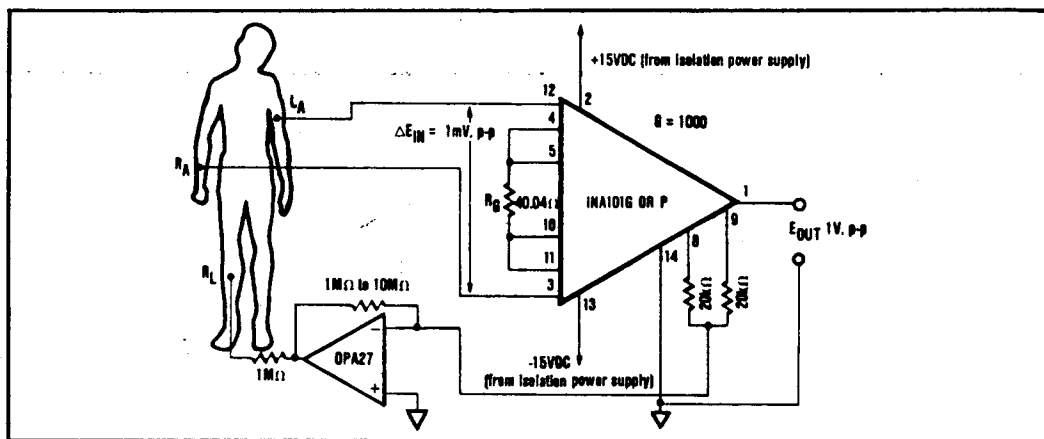

FIGURE 7. ECG Amplifier or Recorder Preamp for Biological Signals.

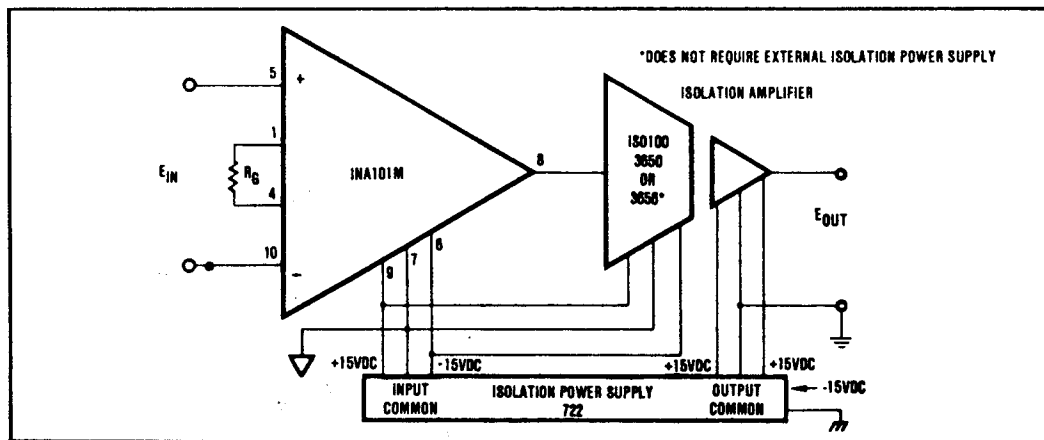

FIGURE 8. Precision Isolated Instrumentation Amplifier.

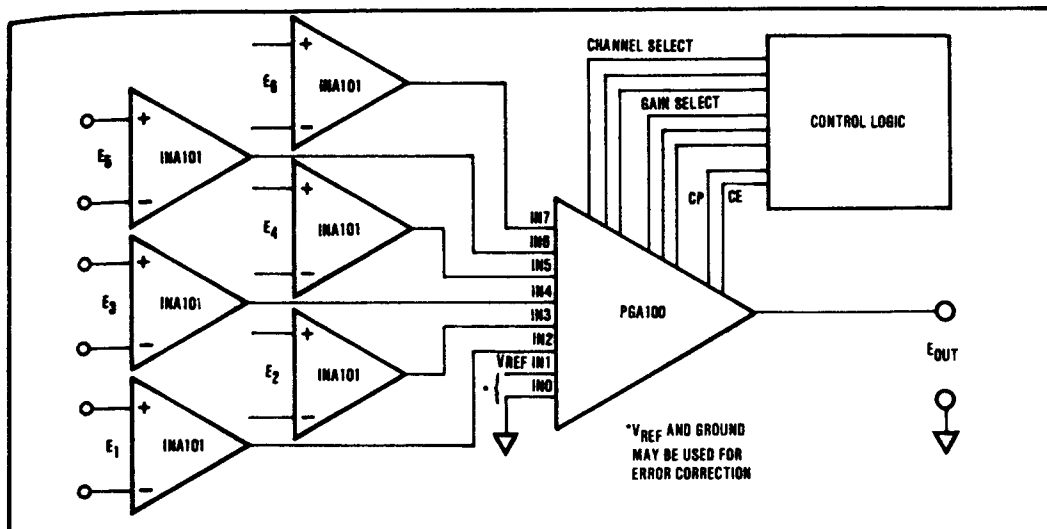

FIGURE 9. Multiple Channel Precision Instrumentation Amplifier.

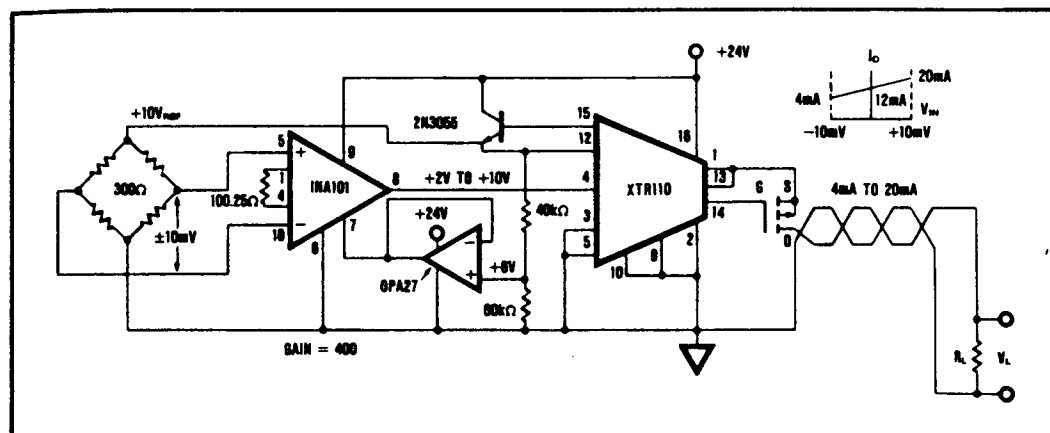

FIGURE 10. 4mA to 20mA Bridge Transmitter Using Single Supply Instrumentation Amplifier.

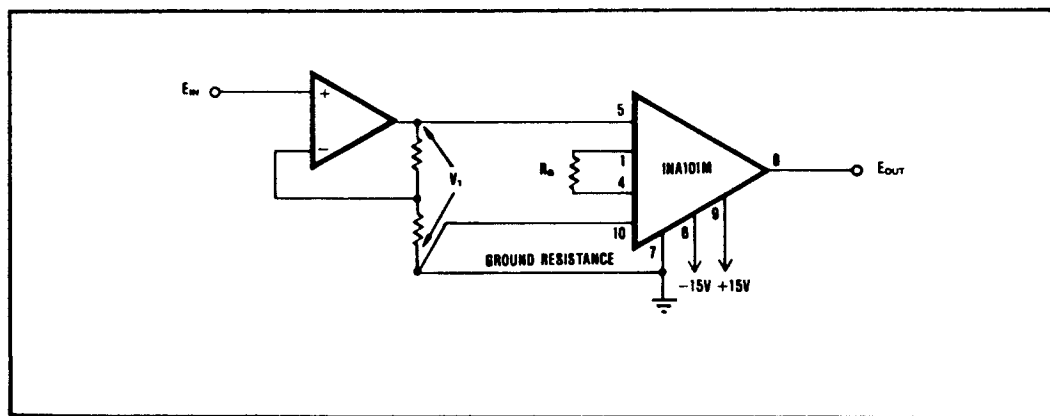

FIGURE 11. Ground Resistance Loop Eliminator (INA101 senses and amplifies V_1 accurately).

5V
Converter.

A SUPPLY

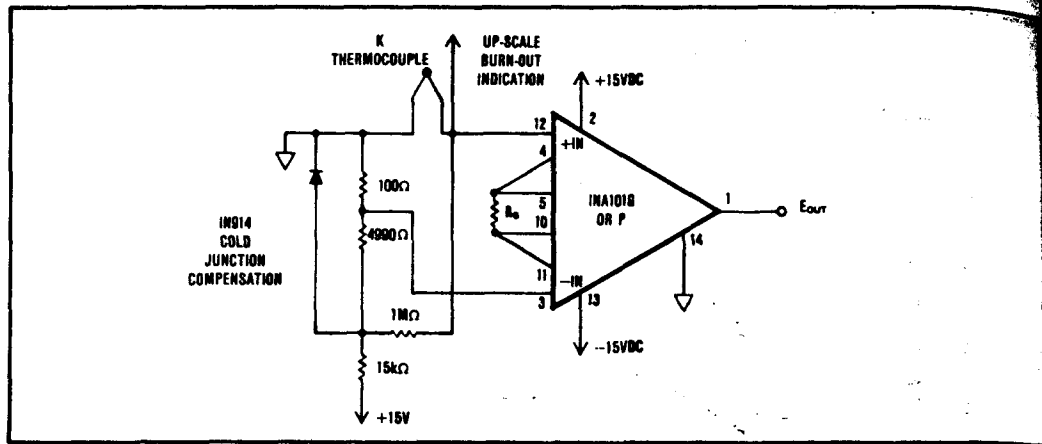

FIGURE 12. Thermocouple Amplifier with Cold Junction Compensation.

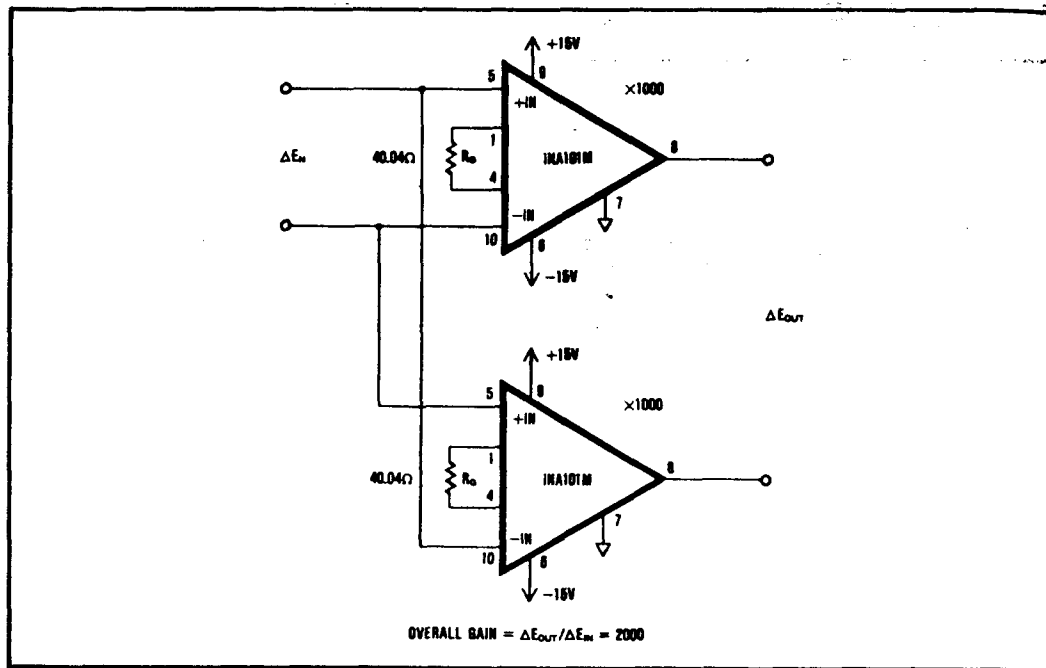

FIGURE 13. Differential Input/Differential Output Amplifier (twice the gain of one INA).

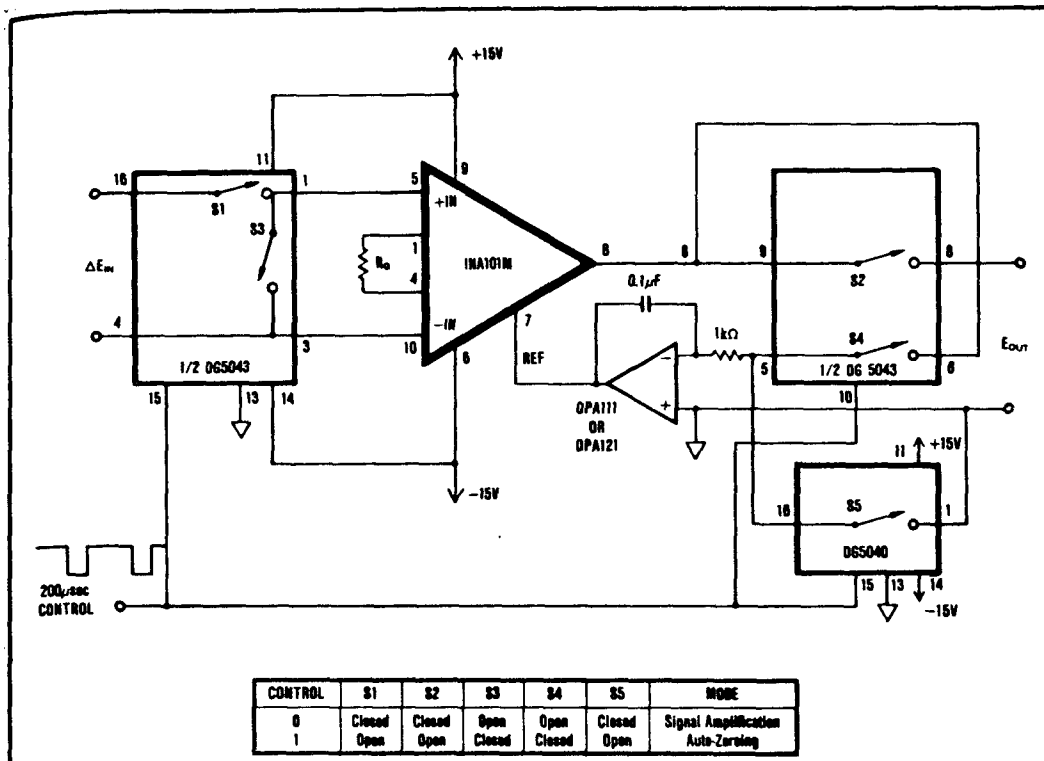

FIGURE 14. Auto-Zeroing Instrumentation Amplifier Circuit.

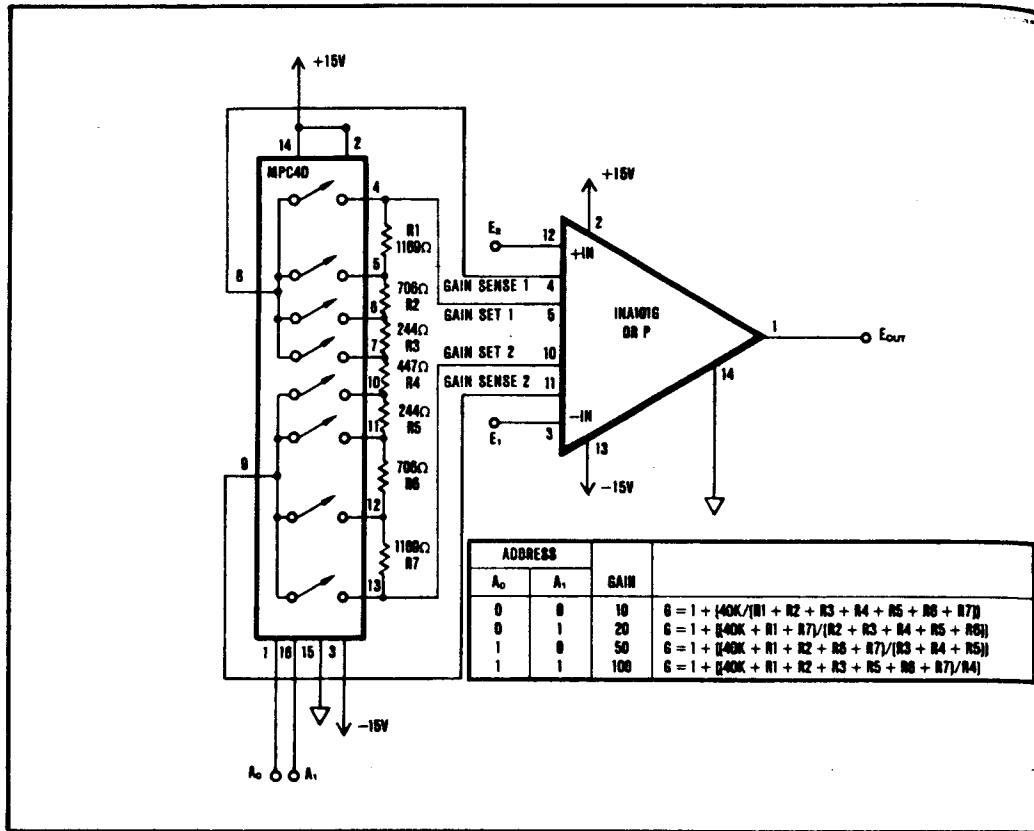

FIGURE 15. Programmable Gain Instrumentation Amplifier.

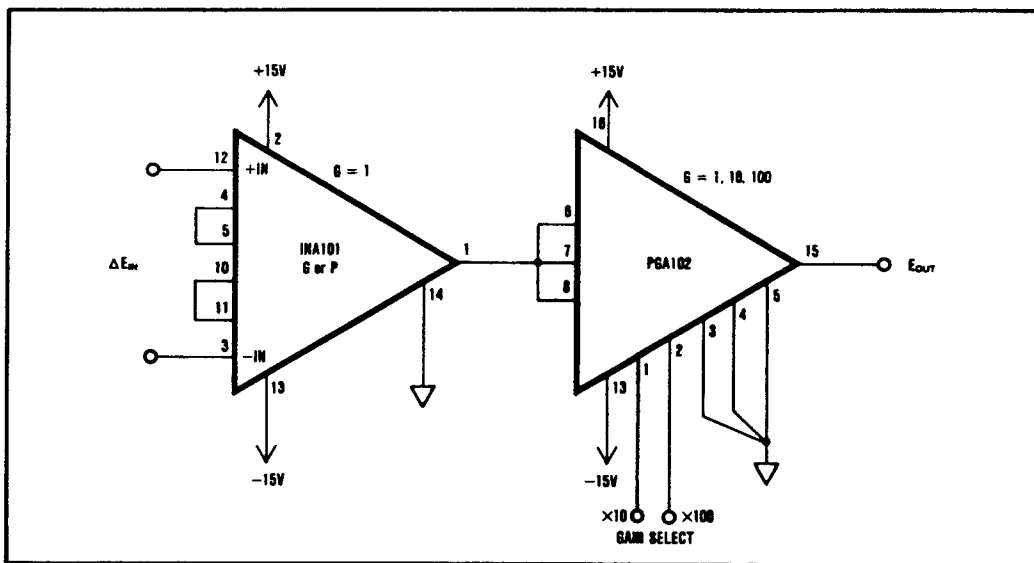

FIGURE 16. Programmable-Gain Instrumentation Amplifier Using the INA101 and PGA102.

FEAT
 • LOW-C
 • INTER
 • LOW-C
 • TH
 • LOW-I
 • LOW-I
 • LOW
 • HIGH-
 • LOW

DES
 The IN
 mentat
 applica
 On-chi
 peratu
 laser-ti
 and co
 sive e)
 INA10
 volum
 The I)
 100 or
 appro
 gains.
 CMR
 additi
 the ou

