

INSTRUCTION MANUAL
MODEL 427
CURRENT AMPLIFIER

© 1975, KEITHLEY INSTRUMENTS, INC.
CLEVELAND, OHIO, U.S.A.
DOCUMENT NUMBER 29103

CONTENTS

<u>Section</u>	<u>Page</u>
SPECIFICATIONS-----	iv
1. GENERAL DESCRIPTION-----	1
2. OPERATION-----	4
3. APPLICATIONS-----	9
4. ACCESSORIES-----	10
5. CIRCUIT DESCRIPTION-----	12
6. REPLACEABLE PARTS-----	17
7. CALIBRATION-----	26
SCHEMATICS-----	33

ILLUSTRATIONS

Figure No.	Title	Page
1	Front Panel. -----	1
2	Front Panel Controls. -----	3
3	Rear Panel Controls. -----	3
4	Shunt Method Measurement. -----	4
5	Effect of Shunt Capacitance. -----	4
6	Compensation for Shunt Capacitance. -----	5
6b	Extended Frequency Response. -----	5
7	Feedback Method. -----	6
8	Input Voltage Noise. -----	6
9	Bandwidth of Feedback System. -----	7
9b	Effect of filter on Noise Spectrum. -----	7
9c	Effect of Input Capacitance on Noise. -----	7
10	Frequency Compensation. -----	7
11	Plot of Noise-Improvement Contours. -----	9
12	Block Diagram of a High-Speed Current Amplifier. --	12
13	Filter Circuit. -----	13
14	Power Supply Regulator. -----	13
15	Current Suppression. -----	13
16	Component Layout - PC-291. -----	13
17	Component Layout - PC-290. -----	14
18	Component Layout - PC-289. -----	15
19	Component Layout - PC-292. -----	15
20	Chassis - Top View. -----	16
21	Chassis Assembly - Exploded View. -----	19
22	Bottom Cover Assembly. -----	19
23	Measurement of Input Voltage Drop. -----	27
24	Measurement of Rise Time. -----	28
25	Measurement of Filter Rise Time. -----	29

SPECIFICATIONS

RANGE: 10^4 to 10^{11} volts/ampere in eight decade ranges. (10^{-13} ampere resolution to 10^{-3} ampere full output).

OUTPUT: ± 10 volts at up to 3 milliamperes.

OUTPUT RESISTANCE: Less than 10 ohms dc to 30 kHz.

OUTPUT ACCURACY: $\pm 2\%$ of reading to the 10^9 volts/ampere range, $\pm 4\%$ of reading on the 10^{10} and 10^{11} volts/ampere ranges exclusive of noise, drift and current offset.

RISE TIME (10% to 90%): Adjustable in 1x and 3.3x steps from "Fast Rise Time" listed below to 330 msec.

NOISE VS. RISE TIME*:

Gain V/A	FAST RISE TIME			WIDE DYNAMIC RANGE		
	Rise Time (10%-90%)	Dynamic Range	Noise (ampere rms)	Dynamic Range	Noise (ampere rms)	Rise Time (10%-90%)
10^{11}	1.5 ms	100	4×10^{-13}	1.3×10^4	3×10^{-14}	330 ms
10^{10}	400 μ s	200	2×10^{-12}	2×10^4	2×10^{-14}	100 ms
10^9	220 μ s	400	1×10^{-11}	2×10^4	2×10^{-13}	10 ms
10^8	60 μ s	800	5×10^{-11}	2×10^4	2×10^{-12}	1 ms
10^7	40 μ s	2000	2×10^{-10}	2×10^4	2×10^{-11}	100 μ s
10^6 - 10^4	15 μ s	2000	—	2×10^4	—	100 μ s

*With up to 100 pF input shunt capacitance. Noise and/or rise time increase as input shunt capacitance increases (1000 picofarads maximum).

STABILITY: Current offset doubles per 10°C above 25°C . Voltage drift is less than 0.005% per $^\circ\text{C}$ and less than 0.005% per day of full output after 1-hour warmup.

OFFSET CURRENT: Less than 10^{-12} ampere at 25°C and up to 70% relative humidity.

CURRENT SUPPRESSION: 10^{-10} ampere to 10^{-3} ampere in eight decade ranges with 0.1% resolution (10-turn potentiometer). Stability is $\pm 0.2\%$ of suppressed value per $^\circ\text{C}$ $\pm 0.2\%$ per day.

INPUT VOLTAGE DROP: Less than 400 μV for full-scale output on the 10^6 to 10^{11} volts/ampere ranges when properly zeroed.

EFFECTIVE INPUT RESISTANCE: Less than 15 ohms on the 10^4 and 10^5 volts/ampere ranges, increasing to less than 4 megohms on the 10^{11} volts/ampere range.

MAXIMUM INPUT OVERLOAD: Transient: 1000 volts on any range for up to 3 seconds using a Keithley (or other 10 mA-limited) high-voltage supply. **Continuous:** 500 volts on the 10^{11} to 10^7 volts/ampere ranges, decreasing to 200 on the 10^6 , 70 on the 10^5 and 20 volts on the 10^4 volts/ampere ranges.

OVERLOAD INDICATION: Lamp indicates pre-filter or post-filter overload.

DYNAMIC RESERVE: 10 (20 dB).

CONNECTORS: Input: (Front) BNC. Output: (Front and Rear) BNC.

POWER: 90-125 or 180-250 volts (switch selected), 50-60 Hz, 5 watts.

DIMENSIONS; WEIGHT: Style M $3\frac{1}{2}$ " half-rack, overall bench size 4" high x $8\frac{1}{2}$ " wide x $12\frac{1}{8}$ " deep (100 x 217 x 310 mm). Net weight, 7 lbs. (3.0 kg).

SECTION 1. GENERAL DESCRIPTION

1-1. GENERAL: The Model 427 Current Amplifier is a high-speed, feedback-type amplifier with particular features useful for automated semiconductor testing, mass spectrometry, and gas chromatography applications.

1-2. FEATURES.

a. Wide Dynamic Range. Selectable rise times permit low-noise operation important when resolving small current levels.

b. High Speed. Typical resolution is 20 picoamperes out of a 10^{-8} ampere signal with a 100 microsecond rise time.

c. Built-in Current Suppression. Small changes in the signal level can be measured since large ambient current levels can be easily suppressed.

d. Overload Indication. Accurate measurements are assured since overloads are automatically indicated.

e. Variable Gain. The GAIN Switch is designated in eight gain positions from 10^4 to 10^{11} volts per ampere - therefore gain adjustment is straight forward.

f. Variable Rise Time. Optimum response can be selected for each gain setting since a separate RISE TIME switch is provided on the front panel.

*0.05%
30MS
10-30mV*

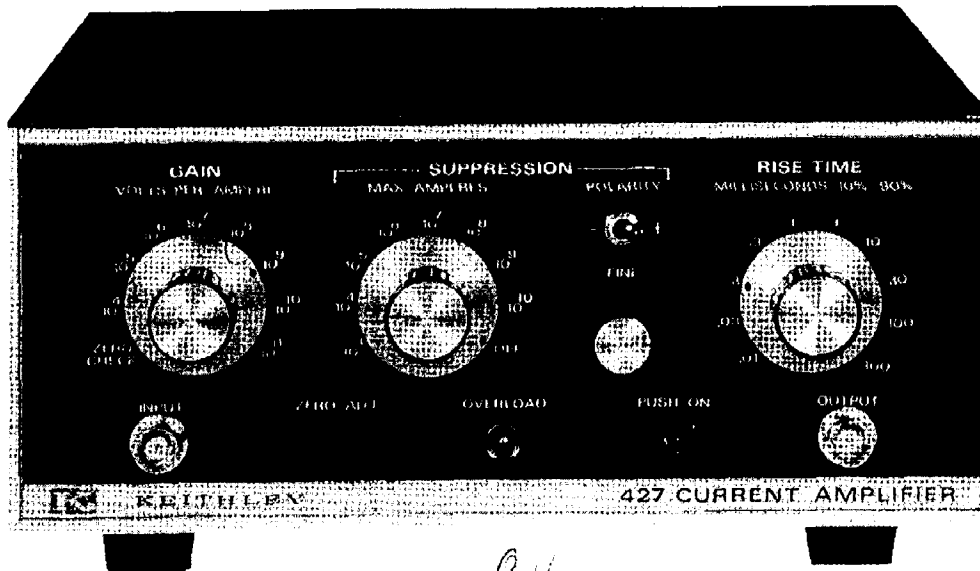

*8V
Brockhausen*

TABLE 1-1.
Front Panel Controls and Terminals

Control or Terminal	Functional Description	Paragraph
<u>PUSH ON</u> Power Switch (S302)	Controls power to instrument.	2-4, a1
<u>GAIN</u> Switch (S201)	Sets gain in volts per ampere.	2-4, a2
<u>RISE TIME</u> (S101)	Sets rise time in milliseconds.	2-4, a3
<u>SUPPRESSION</u>		
MAX AMPERES Switch (S303)	Sets maximum suppression.	2-4, a4
FINE Control (R333)	Adjusts suppression.	2-4, a5
POLARITY Switch (S304)	Sets polarity of suppression.	2-4, a6
<u>ZERO ADJ</u> Control (R235)	Adjusts output zero.	2-4, a7
<u>INPUT</u> Receptacle (J202)	Input source connection.	2-3, a
<u>OUTPUT</u> Receptacle (J102)	Output connection.	2-3, b
<u>OVERLOAD</u> Indicator (DS302)	Indicates overload condition.	2-5, d

TABLE 1-2.
Rear Panel Controls and Terminals

Control or Terminal	Functional Description	Paragraph
Line Switch (S301)	Sets instrument for 117V or 234V.	2-4, b
Power Receptacle (P305)	Connection to line power.	2-3, c
Fuse (F301)	Type 3AG Slow-Blow, 117V @ 1/4 A (FU-17) 234V @ 1/8 A (FU-20)	- -
OUTPUT Receptacle (J103)	Output Connection.	2-3, b

WARNING

Using a Line Power Cord other than the one supplied with your instrument may result in an electrical shock hazard. If the Line Power cord is lost or damaged, replace only with Keithley Part No. CO-7.

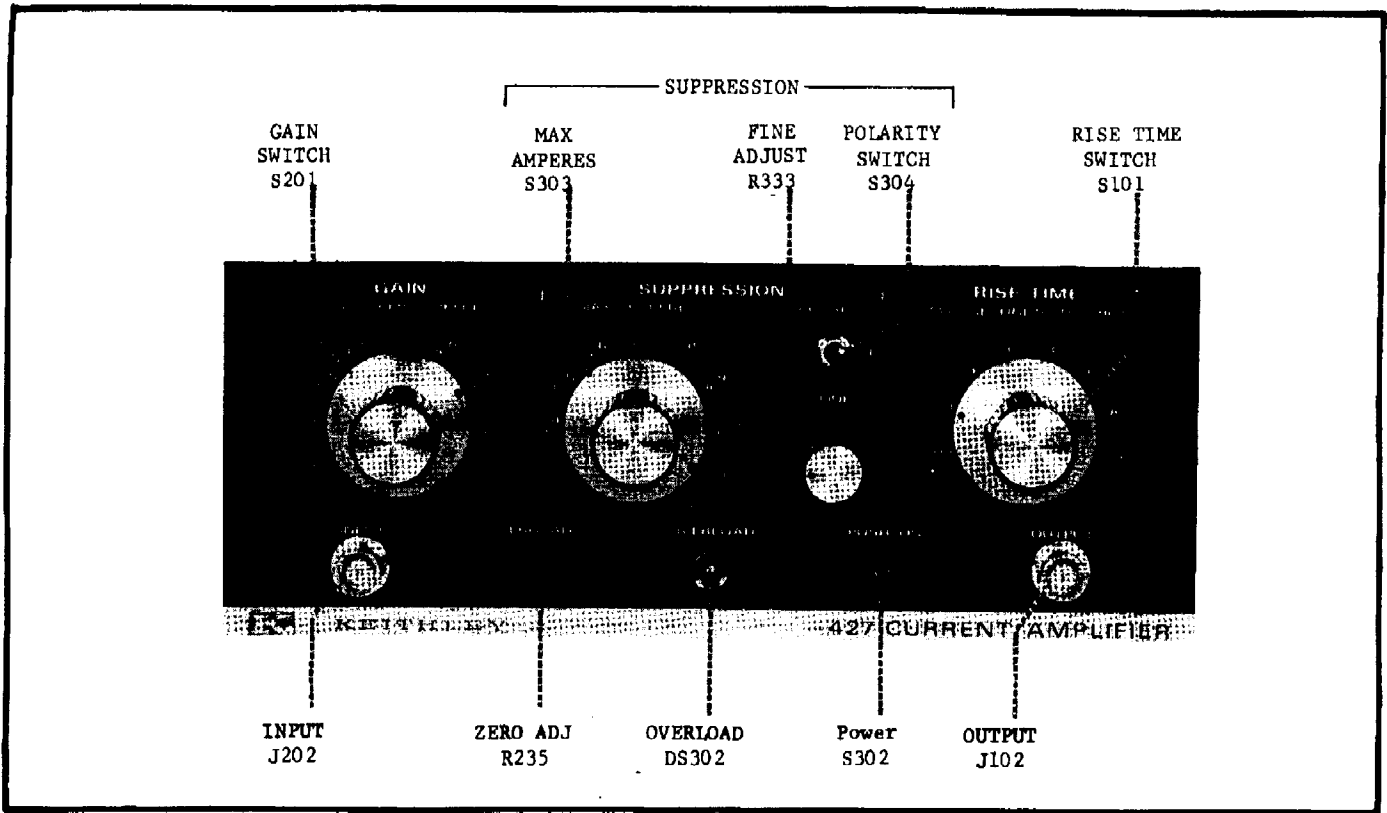

FIGURE 2. Front Panel Controls.

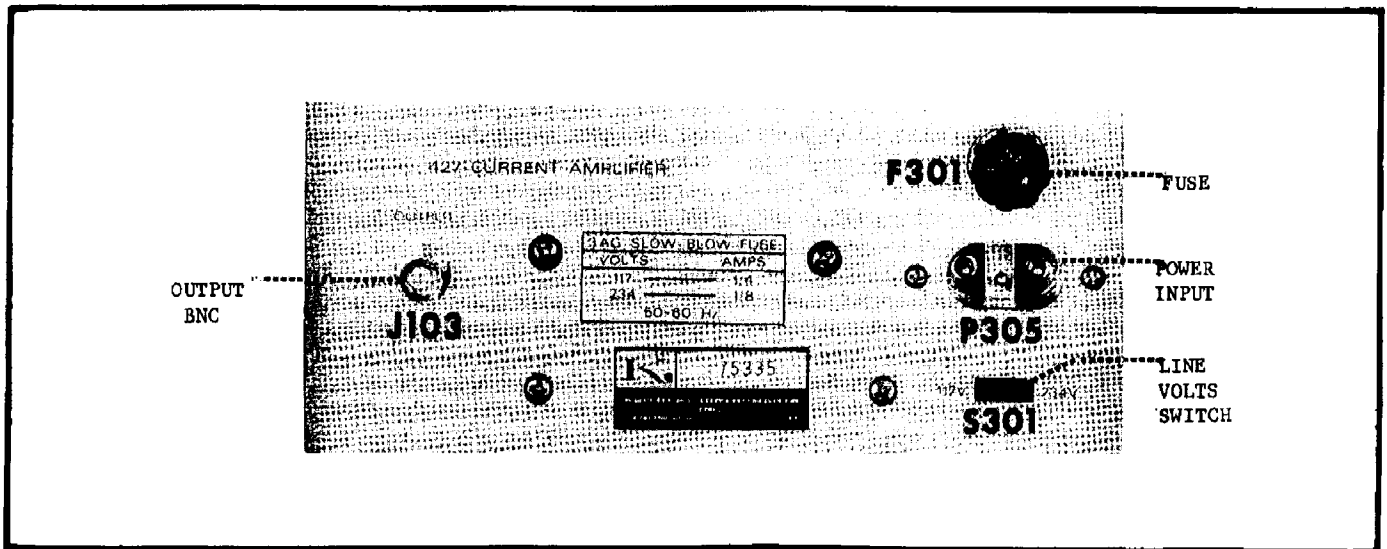

FIGURE 3. Rear Panel Controls.

SECTION 2. OPERATION

2-1. MEASUREMENT CONSIDERATIONS.

a. Current-Detection Devices. The measurement of small electrical currents has been the basis for a number of instrumental methods used by the analyst. Ion chambers, high-impedance electrodes, many forms of chromatographic detectors, phototubes and multipliers are commonly-used transducers which require the measurement of small currents. Devices used for this measurement are often called electrometers.

b. Current-Detection Limitations. In any measurement, if source noise greatly exceeds that added by the instrumentation, optimization of instrumentation is unimportant. When source noise approaches theoretical minimum, optimization of instrumentation characteristics becomes imperative. To determine the category into which this measurement falls, the researcher needs to be familiar with the characteristics which impose theoretical and practical limitations on his measurement. Most researchers are familiar with the theoretical limitations present in voltage measurements. The noise increases with source resistance, and the familiar equation for the mean-square noise voltage is

$$\overline{e_n^2} = 4kTR \Delta f \quad \text{Eq. 1}$$

where k is the Boltzmann Constant, T is the absolute temperature of the source resistance R , and Δf is the noise bandwidth ($\frac{1}{2}$ times the 3 dB bandwidth for a single RC rolloff.) In the case of current measurements it is more appropriate to consider the noise current generated by the source and load resistances. The mean square noise current generated by a resistor is given by Eq. 2.

$$\overline{i_n^2} = \frac{4kT \Delta f}{R} \quad \text{Eq. 2}$$

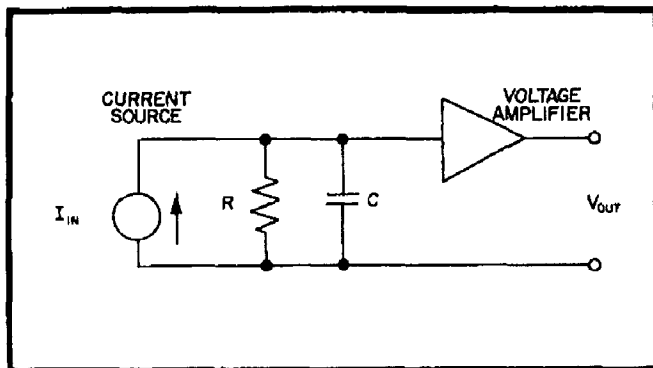

FIGURE 4. In the shunt method current is measured by the voltage drop across a resistor.

From this equation it is immediately apparent that the measurement of small current requires large values of R , i.e., high impedance levels. However, this gives difficulties for measurements requiring wide bandwidths because of the RC time constant associated with a high-megohm resistor and even a few picofarads of circuit capacitance. Figure 4 shows a current source generating a voltage across a parallel RC. The frequency response of this current measurement is limited by the RC time constant. Figure 5 shows this response and the -3 dB point occurs at a frequency

$$F_0 = \frac{1}{2\pi RC} \quad \text{Eq. 3}$$

Low noise and high speed, therefore, are contradictory requirements. To optimize a current-measuring system, techniques must be used which obtain high speed using high-impedance devices.

c. High Speed Methods.

1. High speed can, of course, be obtained in a shunt-type measurement by using a low value for the shunt resistor. As pointed out above, such a small resistor value introduces excessive noise into the measurement.

2. A second method to achieve bandwidth is to keep R large, to accept the frequency roll-off starting at F_0 , and to change the frequency response of the voltage amplifier as shown in Figure 6a. The combined effects of the RC time constant followed by this amplifier is shown in Figure 6b and it is seen that the frequency response of the current measurement has been extended to F_1 . The frequency at which the amplifier gain starts to increase must be exactly equal to the frequency F_0 determined by the RC time constant in order for this approach to result in a flat frequency response. Therefore,

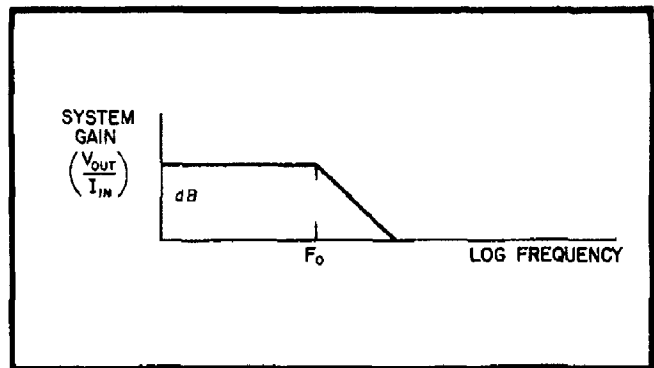

FIGURE 5. The frequency response of the shunt method is limited by omnipresent shunt capacitance.

this method is useful only for applications where the shunt capacitance C is constant. Aside from this drawback this is a legitimate approach which is being used in low-noise, high-speed current-measuring applications. In addition to current noise in the shunt and in the amplifier input stage, a major source of noise in this system arises from the voltage-noise generator associated with the input stage (reflected as current noise in the shunt resistor) caused by the high-frequency peaking in the following stages of amplification. More will be said about this in the discussion on noise behavior.

3. A third method used for speeding up a current measurement uses guarding techniques to eliminate the effects of capacitances. Unfortunately only certain types of capacitances, such as cable capacitances, can be conveniently eliminated in this manner. To eliminate the effect of parasitic capacitances associated with the source itself becomes very cumbersome and may not be feasible in many instances. The major sources of noise in this system are identical to those mentioned in the second system.

4. A fourth circuit configuration combines the capability of low-noise and high-speed performance with tolerance for varying input C and eliminates need for separate guard by making the ground plane an effective guard. This is the current-feedback technique. This technique gives a typical improvement of 3 over shunt techniques. Again, the major sources of noise are identical to those mentioned in the second system.

d. Noise in Current Measurements. Noise forms a basic limitation in any high-speed current-measuring system. The shunt system gives the simplest current measurement but does not give low-noise performance. A properly designed feedback system gives superior noise - bandwidth performance. Noise in these two systems will be discussed next.

1. Noise Behavior of the Shunt System. High speed and low noise are contradictory requirements in any current measurement because some capacitance is always present. The theoretical performance limitation of the shunt system can be calculated as follows:

The rms thermal noise current (i_n) generated by a resistance R is given by

$$i_n = \sqrt{\frac{4kT}{R} \Delta f} \quad \text{Eq. 4}$$

The equivalent noise bandwidth (Δf) of a parallel RC combination is $\Delta f = 1/(4RC)$ and the signal bandwidth (3 dB bandwidth) $F_0 = 1/(2\pi RC)$. For practical purposes peak-to-peak noise is taken as 5 times the rms value. The peak-to-peak noise current can now be written as

$$i_{npp} = 2 \times 10^{-9} F_0 \sqrt{C} \quad \text{Eq. 5}$$

In practice, a typical value for shunt capacitance is 100 picofarads. With this value the following rule-of-thumb is obtained. The lowest ratio of detectable current divided by signal bandwidth using shunt techniques is $2 \cdot 10^{-14}$ ampere/Hertz for a peak-to-peak signal-to-noise ratio equal to 1. A corollary for this rule-of-thumb expresses the noise current in terms of obtainable risetime (10-90% risetime $t_r = 2.2 RC$). The lowest product of detectable current and risetime using shunt techniques is 7×10^{-15} ampere seconds. In this derivation it has been assumed that the voltage amplifier does not contribute noise to the measurement.

2. Noise Behavior of the Feedback System. There are three sources of noise in the feedback system that have to be looked at closely. The first two, input-stage shot noise and current noise from the measuring resistor, are rather straight-forward. The third, voltage noise from the input device of the amplifier, causes some peculiar difficulties in the measurement. Any resistor connected to the input injects white current noise (Eq. 4). In the circuit of Figure 7 the only resistor that is connected to the input is the feedback resistor R. As in the shunt system, R must be made large for lowest noise. Because this noise is white, the total contribution can be calculated by equating Δf to the equivalent noise bandwidth of the system. The second source of noise is the current noise from the amplifier input. This component is essentially the shot noise associated with the gate leakage current (i_0) of the input device. Its rms value equals ...

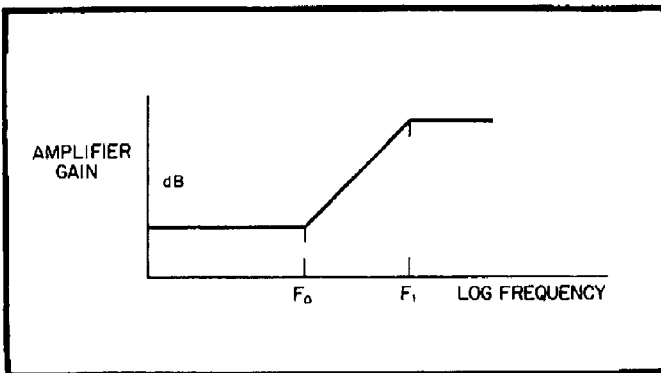

FIGURE 6. By tailoring the frequency response of the amplifier (Fig. 6a) the frequency response of the shunt method can be extended.

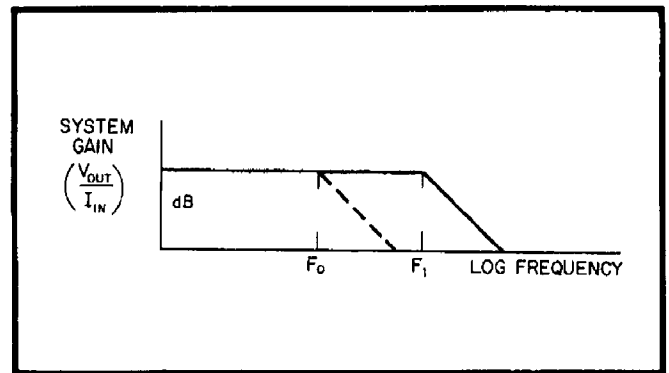

FIGURE 6b. Extended frequency response.

$$\overline{i_n} = \sqrt{2 e i_o \Delta f} \quad \text{Eq. 9}$$

where e is the electronic charge. The contribution of this noise generator is also white. Not only do these two noise sources generate white current noise, the noise in a given bandwidth is also independent of the input capacitance C . The major source of noise in a feedback current measurement is the noise contribution associated with the voltage noise of the input amplifier. The voltage noise can be represented by a voltage noise generator (e_n) at the amplifier input as shown in Figure 8. This noise generator itself is assumed to be white. However, its total noise contribution to the current-measuring system is not white. Inspection of Figure 8 will reveal that at low frequencies a large amount of feedback is applied around the voltage noise source (e_n). However, the RC combination attenuates the high-frequency components of V_{out} so that no feedback is present at high frequencies. Thus, the noise contribution to the output voltage V_{out} from the voltage noise source e_n is no longer independent of frequency. The noise is "colored" and increases in intensity for all frequencies higher than F_0 . The resulting noise spectrum is shown in Figure 9b. The total system noise is related to the area under this curve. Because the logarithm of frequency is plotted on the horizontal axis, the area under the curve at higher frequencies represents a significantly larger amount of noise than a similar area at low frequencies. For comparison, Figure 9a shows the frequency response of the current measuring system. Figure 9a is identical to Figure 6b. It is interesting at this point to compare this noise spectrum with the frequency response of the voltage amplifier in Figure 4 as shown in Figure 6a. A voltage noise source at the input of the amplifier would generate a noise spectrum according to the amplifier frequency response as shown in Figure 6a. The noise spectrum of such a system, then, is identical to the noise spectrum of the feedback system as given in Figure 9b. This illustrates the well-known fact that signal-to-noise performance of a measurement cannot be improved by feedback techniques. At the high-frequency end the voltage noise is limited by the frequency F_A which is the high-frequency roll-off point of the operational amplifier. It should

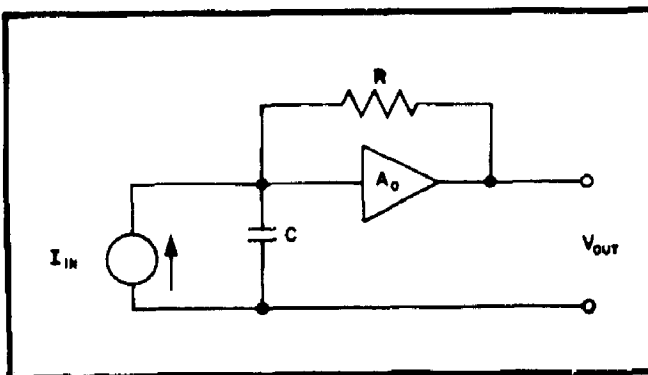

FIGURE 7. Basic circuit configuration for the feedback method.

be noted that even though the useful bandwidth of the system extends only to F_1 , there are noise components of higher frequency present. To obtain best wideband-noise performance, these high-frequency noise components have to be removed. This can be achieved by adding a low-pass filter section following the feedback input stage. If the band-pass of this low-pass filter is made adjustable this filter can serve the dual purpose of removing high-frequency noise and of limiting the signal bandwidth of the system.

2-2. THEORY OF OPERATION.

a. Current Feedback Technique. The basic circuit configuration used in the current-feedback technique is shown in Figure 7. In this configuration the current-measuring resistor R is placed in the feedback loop of an inverting amplifier with a gain of A_0 . The frequency response obtained with this circuit is identical to that shown in Figure 6b. F_0 again is the frequency associated with the RC time constant:

$$F_0 = \frac{1}{2\pi RC} \quad \text{Eq. 6}$$

The frequency response of the system is extended to a frequency f_1 where

$$F_1 = A_0 F_0 \quad \text{Eq. 7}$$

Note that the frequency response is automatically flat without having to match break points. However, the total bandwidth of the system (F_1) is still limited by the value of the shunt capacitance C across the input. This improved frequency response of the feedback technique avoids the use of low values for R which could generate excessive current noise.

b. Refinements of the Feedback System. A major difficulty of the feedback system arises from shunt capacitance associated with the high-megohm resistor R in the feedback path. If the shunt capacitance across the resistor is C_f , then the bandwidth (F_f) of the system is determined by the time constant RC_f :

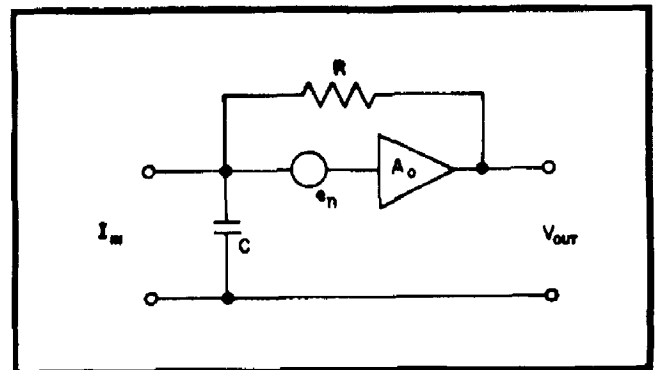

FIGURE 8. The voltage noise associated with the amplifier input device is an important source of noise in the high-speed feedback system.

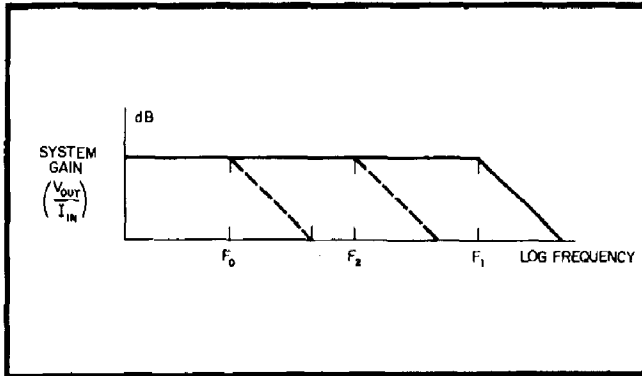

FIGURE 9. The bandwidth of the high-speed feedback system (Fig. 9a) can be limited by using a filter with either a -6 dB/octave or a -12 dB/octave roll-off. The effect of the filter on the noise spectrum is shown in Fig. 9b. Effect of input capacitance on noise is shown in Fig. 9c.

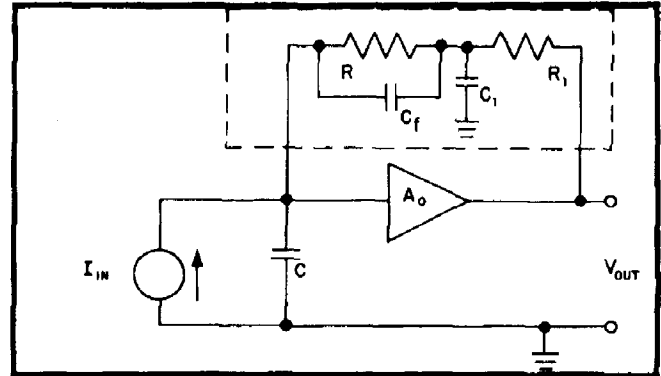

FIGURE 10. Frequency compensation.

$$F_F = \frac{1}{2\pi RC_F} \tag{Eq. 8}$$

A slight modification of the feedback loop can correct this problem as shown in Figure 10. If the time constant R_1C_1 is made equal to the time constant $R \cdot C_F$, it can be shown that the circuit within the dotted line behaves exactly as a resistance R . The matching of time constants in this case does not become a drawback because the capacitances involved are all constant and not affected by input impedance.

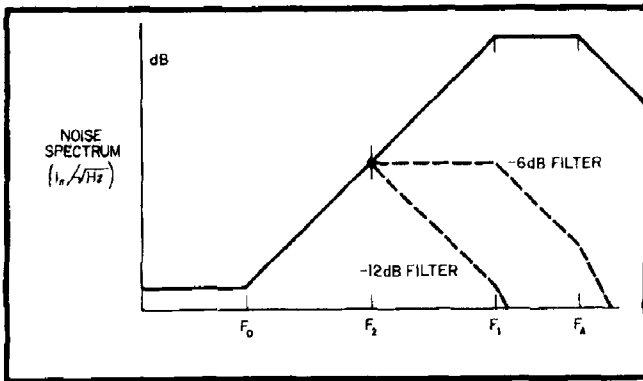

FIGURE 9b. Effect of filter on noise spectrum.

c. -12 dB/octave Filter.

1. Theory. To obtain optimum wideband noise performance a filter with a single high-frequency roll-off (i.e., -6 dB/octave) is not sufficient and -12 dB/octave is required. The effect of a -6 dB filter is shown in Figure 9a and b. The filter is used to limit the system bandwidth to a frequency F_2 , smaller than F_1 . The effect of this filter on the noise spectrum is shown in Figure 9b. It can be seen that there are again high-frequency noise components above F_2 , the useable bandwidth of the system. These can be eliminated by using a filter with a -12 dB/octave roll-off. The result of such a filter on noise performance is also shown in Figure 9b.

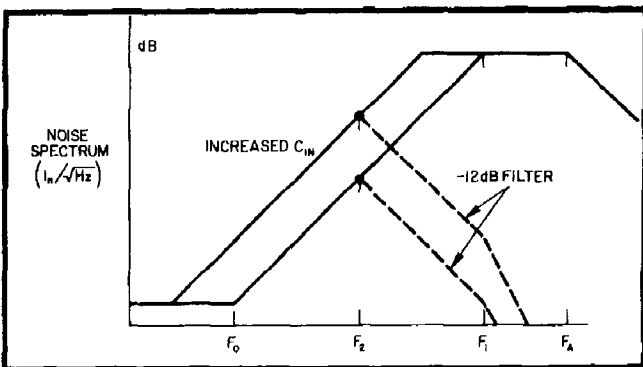

FIGURE 9c. Effect of input capacitance on noise.

2. Model 427. The input amplifier is followed by an adjustable low-pass filter having a -12 dB/octave roll-off and a voltage gain of 10X. The voltage gain in the low-pass filter avoids premature overloading in the input amplifier which can be seen as follows. The maximum output voltage V_{out} is ± 10 volts. The maximum signal level at the input of the low-pass filter is, therefore, ± 1 volt. At this point in the circuit, wide-band noise could still be present and exceed the 1-Volt signal level. The voltage gain of 10 in the filter allows the total pre-filter wide-band noise to exceed the full scale signal by a factor of 10 (20 dB). The frequency response of this filter is adjustable for variable "damping" control.

2-3. CONNECTIONS.

a. Input. The input receptacle (J202) is a BNC type which mates with coaxial cables such as Keithley Models 8201 and 8202. The inner contact is circuit high. The outer shell is low or chassis ground.

b. Output. Two output receptacles are provided (J102 on the front, J103 on the rear panel). These are BNC types where the inner contact is output high and the outer shell is chassis ground.

c. Power Input. The power receptacle (P305) on the rear panel is a 3-prong connector which mates with Keithley part number CO-6 line cord.

2-4. CONTROLS.

a. Front Panel.

1. Power Switch "PUSH ON" (S302). This switch controls the line power to the instrument. The switch is a special pushbutton type with "Power On" indicated by a self-contained pilot lamp.

2. GAIN (VOLTS PER AMPERE) (S201). This switch sets the overall gain in eight positions from 10^4 to 10^{11} . A "ZERO CHECK" position permits adjustment of zero offsets.

3. RISE TIME Switch (S101). This switch sets the 10-90% rise time in 10 positions from .01 to 300 milliseconds (for the filter section only).

4. SUPPRESSION (MAX) Switch (S303). This switch sets the maximum current suppression in eight positions from 10^{-10} to 10^{-3} A. When the switch is set to "OFF" the current suppression circuit is disabled.

5. SUPPRESSION (FINE) Control (R333). This control permits adjustment of suppression with 0.1% resolution.

6. SUPPRESSION (POLARITY) Switch (S304). This switch sets the polarity of the current suppression (referred to the input).

7. ZERO ADJUST Control (R235). This control permits adjustment of zero offset through the use of the OVERLOAD indicator.

b. Rear Panel.

1. Line Voltage Switch (S301). Sets instrument for either 117 or 234 V operation.

Fuse Requirements 3AG, Slo-Blo

117V: 1/4A Keithley No. FU17
234V: 1/8A Keithley No. FU-20

2-5. OPERATING CONSIDERATIONS.

a. Gain. The gain of the Model 427 is defined in terms of volts per ampere. Since the output level is 10 volts for a full scale input, the gain could also be expressed as sensitivity in amperes referred to the input as in Table 2-1. $V_{out} = - (I_{in} \times \text{GAIN})$ Eq. 9

TABLE 2-1.
Gain or Sensitivity Referred to the Input

GAIN Setting	Feedback Resistor	Full Scale Sensitivity (Amperes)	Full Scale Output (Volts)
10^4	10^3	1×10^{-3}	10
10^5	10^4	1×10^{-4}	10
10^6	10^5	1×10^{-5}	10
10^7	10^6	1×10^{-6}	10
10^8	10^7	1×10^{-7}	10
10^9	10^8	1×10^{-8}	10
10^{10}	10^9	1×10^{-9}	10
10^{11}	10^{10}	1×10^{-10}	10

b. Rise Time. The rise time for each gain setting is listed in the specifications as "FAST RISE TIME". These rise times are obtained when the RISE TIME switch is set to the positions indicated in Table 2-2.

TABLE 2-2.
Switch Settings for "FAST RISE TIME"

GAIN Setting	Rise Time	RISE TIME Settings	Dynamic Range
10^4	15 μ s	.01 ms	2000
10^5	15 μ s	.01 ms	2000
10^6	15 μ s	.01 ms	2000
10^7	40 μ s	.03 ms	2000
10^8	60 μ s	.03 ms	800
10^9	220 μ s	.1 ms	400
10^{10}	400 μ s	.3 ms	200
10^{11}	1.5 ms	1 ms	100

c. Suppression. Current suppression is provided in the Model 427 for suppression of input currents up to 10^{-3} amperes. By suppressing background currents, small variations in a larger signal can be observed. Currents of either polarity can be suppressed. To suppress an input current the SUPPRESSION should be set to supply a current of opposite polarity. The FINE control permits adjustment up to 1.5 times the MAX setting.

d. Overloads. The overload sensing circuit detects an overload at two places in the circuit: before and after the "RISE TIME" filter circuit. The OVERLOAD lamp (DS302) will indicate whenever the voltage sensed is greater than full scale regardless of the RISE TIME setting or the frequency.

e. Zero Adjust. The ZERO CHECK position grounds the input of the instrument and converts the current amplifier to a high-gain voltage amplifier. The amplified offset voltage will turn on the OVERLOAD indicator whenever the input voltage offset exceeds $\pm 100 \mu$ V. Therefore the ZERO control should be adjusted so that the OVERLOAD indicator is off when in ZERO CHECK mode, yielding the specified input voltage drop.

SECTION 3. APPLICATIONS

3-1. CURRENT MEASURING SYSTEM. The typical current measuring system consists of a current source, a current amplifier, and a monitoring device. The current source could include an ion chamber, photomultiplier, or other high-impedance device. The current amplifier such as the Model 427 provides sufficient gain to drive a monitoring device such as a chart recorder or other readout. The Model 427 in this case provides an output voltage which is calibrated in volts per ampere as in equation 10.

$$I_{in} = - (V_{out} / GAIN) \quad \text{Eq. 10}$$

Example:

GAIN = 10^6 volts/ampere
 V_{out} = +500 mV
 The input current I_{in} would be:
 $I_{in} = - (5 \times 10^{-1} \text{ volts} / 10^6 \text{ volts per ampere})$
 $I_{in} = - 5 \times 10^{-7}$ amperes

3-2. NOISE BANDWIDTH CONSIDERATIONS. Table 3-1 illustrates the trade-off between fast rise time and dynamic range. For this application dynamic range is defined as the ratio of maximum peak-to-peak current to peak-to-peak current noise. Peak-to-peak current noise is taken as 5-times the rms current noise. The maximum peak-to-peak current is 2-times the maximum full scale current.

NOTE

When using current suppression the current-suppression resistor should be considered as an additional current-noise generator. The values given in Table 3-1 do not include the contribution of the suppression resistor. Therefore the selected suppression resistor R_s , should be as large as possible to minimize the contribution to current noise.

3-3. NOISE-IMPROVEMENT CONTOURS. The sensitivity and speed of the Model 427 (for either d-c or a-c measurements) can be compared to the best performance obtainable with the shunt method of measuring current. The best "noise-risetime" product that can be achieved for d-c measurements (with 100 pF shunt capacitance) in a shunt system is 7×10^{-15} ampere-seconds. However the feedback system achieves 2×10^{-15} ampere-seconds (also with 100 pF shunt capacitance). When used in a-c narrowband systems (lock-in, etc.) the degree of improvement is a function of shunt capacitance and operating frequency. The achievable improvement over the shunt method can be plotted in a graph similar to a set of noise contours. Figure 11 shows the measured improvement (negative dB) that can be obtained with the Model 427 at a given frequency and shunt capacitance when compared to an ideal (noiseless) amplifier in a shunt system.

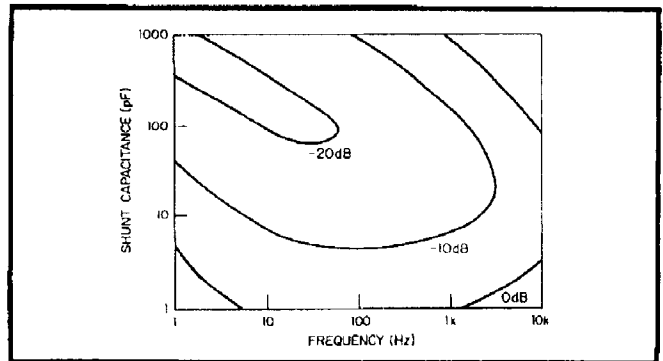

FIGURE 11. Plot of noise-improvement contours.

TABLE 3-1. RMS Noise Current (Typical)¹ as a Function of Gain and Rise-Time Setting

GAIN	MAXIMUM FULL SCALE CURRENT	RISE TIME SETTING									
		AMPERES	300	100	30	10	3	1	.3	.1	.03
10^4	10^{-3}	*	*	*	*	*	*	1×10^{-8}	1.2×10^{-8}	4×10^{-8}	1×10^{-7}
10^5	10^{-4}	*	*	*	*	*	*	1×10^{-9}	1.2×10^{-9}	4×10^{-9}	1×10^{-8}
10^6	10^{-5}	*	*	*	*	*	*	1×10^{-10}	1.2×10^{-10}	4×10^{-10}	1×10^{-9}
10^7	10^{-6}	*	*	*	*	*	1×10^{-11}	1.5×10^{-11}	2×10^{-11}	1×10^{-10}	x
10^8	10^{-7}	*	*	*	*	1×10^{-12}	2×10^{-12}	5×10^{-12}	1×10^{-11}	4×10^{-11}	x
10^9	10^{-8}	*	*	*	2×10^{-13}	2×10^{-13}	5×10^{-13}	2×10^{-12}	5×10^{-12}	x	x
10^{10}	10^{-9}	*	1×10^{-14}	2×10^{-14}	5×10^{-14}	2×10^{-13}	5×10^{-13}	2×10^{-12}	x	x	x
10^{11}	10^{-10}	2×10^{-15}	4×10^{-15}	1×10^{-14}	4×10^{-14}	1×10^{-13}	4×10^{-13}	x	x	x	x

¹ With up to 100 pF input shunt capacitance. Noise increases as input shunt capacitance increases.

KEY:

- x = Filter Bandwidth is greater than current-amplifier bandwidth.
- * = Larger Rise Times are useful for increased filtering of the signal and noise inherent in the source. They do not further improve the instrument noise contribution except when the input shunt capacitance exceeds 100 pF.

SECTION 4. ACCESSORIES

4-1. GENERAL. The following Keithley accessories can be used with the Model 427 to provide additional convenience and versatility.

4-2. OPERATING INSTRUCTIONS. A separate Instruction Manual is supplied with each accessory giving complete operating information.

Model 1007 Rack Mounting Kit

Description:

The Model 1007 is a dual rack mounting kit with overall dimensions 3-1/2 in. (64 mm) high and 19 in. (483 mm) wide. The hardware included in this kit consists of two Angle Brackets, one Mounting Clamp, and extra mounting screws.

Application:

The Model 1007 converts any half-rack, style "M" instrument from bench mounting to rack mounting in a standard 19-inch rack. The kit may also be used for rack mounting 19-inch full rack width instruments.

The Model 1007 Rack Mounting Kit can be used to mount instruments of 11 inch or 14 inch depth. The user should decide the position of the instruments to be rack mounted. The Assembly Instructions refer to instruments positioned as shown and identified as instrument "A" and "B".

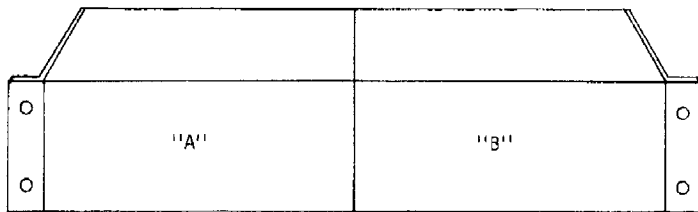

Parts List:

Item No.	Description	Qty Req'd	Keithley Part No.
22	Angle Bracket	2	27410B
23	Screw, #6-32 x 5/8, Phillips Pan Hd	6	--
24	Mounting Clamp	1	24798B
25	Screw, #6-32 x 1, Phillips Pan Hd	1	--
26	Kep Nut #6-32	3	--
27	Screw, #6-32 X 1/2, Phillips Pan Hd	2	--
28	Screw, #6-32 x 7/8, Phillips Pan Hd	1	--

Model 1007 Dual Rack Mounting Kit

Assembly Instructions:

1. Before assembling the rack kit, determine the position of each instrument. Since the instruments can be mounted in either location, their position should be determined by the user's measurement. The following instructions refer to instruments "A" and "B" positioned as shown. For mounting 19-inch full rack width instruments, disregard steps 2 through 5.

2. Once the position of each instrument has been determined, the "side dress" panels on both sides of each instrument should be removed. Removal is accomplished by loosening the screws (Item 8, original hardware) in two places. Slide the "side dress" panels to the rear of the instrument to remove.

3. The mounting clamp is installed on instrument "A" using the original hardware (Item 8). With the screws removed, insert the "mounting clamp" behind the "corner bracket" (Item 7) and replace the screws to hold the mounting clamp in place.

4. Tighten the screws (Item 8) on instrument "B". Insert the "mounting clamp" behind the "corner bracket" (Item 7) on instrument "B" as shown.

5. When mounting instruments having the same depth, a screw (Item 25) and kep nut (Item 26) are required to secure the two instruments together. When mounting instruments of different depth, do not use kep nut (Item 26) but substitute shorter screw (Item 28).

6. Attach an "angle bracket" (Item 22) on each instrument using hardware (Item 23) in place of the original hardware (Item 8). For 14 in. long instruments use #6-32 x 5/8 Phillips screw (Item 23) with #6-32 kep nut (Item 26).

7. The bottom cover feet and tilt bail assemblies may be removed if necessary.

8. The original hardware, side dress panels, feet and tilt bail assemblies should be retained for future conversion back to bench mounting.

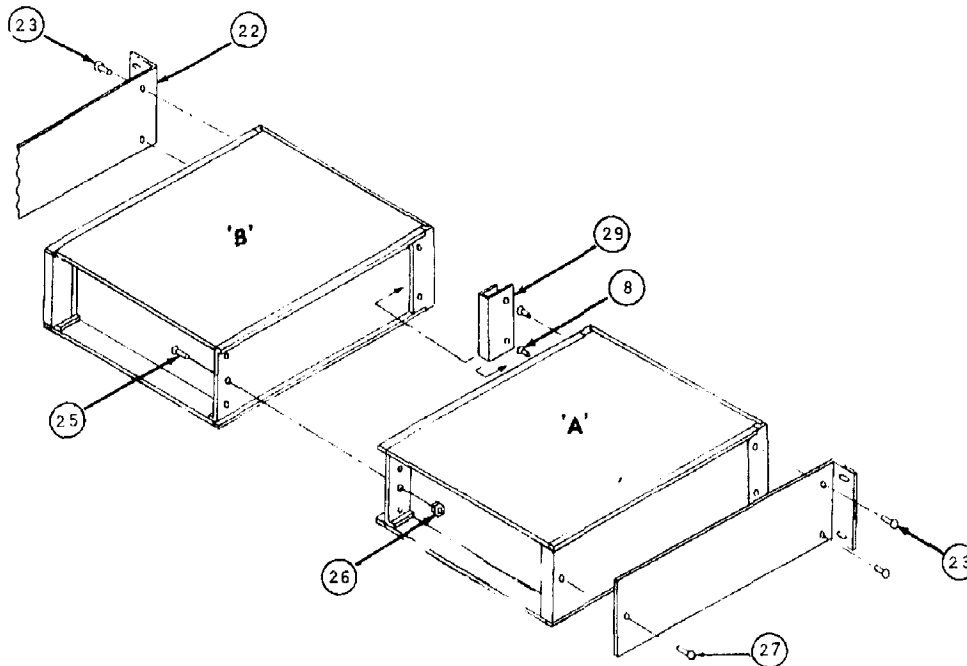

110

SECTION 5. CIRCUIT DESCRIPTION

5-1. GENERAL. The Model 427 is composed of a feedback amplifier, a X10 gain filter section, suppression and power supply circuits as shown in Figure 12. The feedback amplifier is located on the "Amplifier Board", PC-289. The filter circuitry is located on the "Filter Board", PC-291, PC-292. The power supply circuitry is located on the "Mother Board", PC-290.

5-2. FEEDBACK AMPLIFIER (PC-289). The feedback amplifier is composed of a high-gain amplifier connected as a feedback ammeter. The feedback resistors R220 through R227 are set by the GAIN Switch (S201). The high-gain amplifier is composed of a dual FET input stage (Q201A and B), a differential amplifier (QA201), and an output stage (Q203 and Q204). The feedback is connected from resistor R201 to the output stage at Q203 and Q204. Potentiometers R232, R233, and R234 are internal frequency compensation controls for 10^9 , 10^{10} , and 10^{11} gains respectively. Potentiometer R235 is the ZERO ADJ control. The full scale output of the feedback amplifier is 1 volt.

5-3. FILTER (PC-292). The filter circuit is composed of a high-gain amplifier connected as a 12 dB/octave low pass filter as shown in Figure 13. The amplifier consists of integrated circuit QA101 and output stage (Q101 and Q102). Full scale output is 10 volts. The gain is established at X10 by resistors R110 and R112 + R113. Potentiometer R108 is an internal zero adjustment. Potentiometer R113 is an internal gain adjustment.

5-4. POWER SUPPLY (PC-290). The power supply provides +15 V dc at up to 70 mA for the amplifier circuits. The regulator circuits are composed of identical components and are connected as shown in Figure 14.

a. +15 V Regulator. AC power is tapped from one secondary of transformer T301. The ac is rectified by a full-wave bridge rectifier (D301). Transistor Q301 is the series pass regulator. Integrated circuit QA 301 is a self-contained reference and regulating circuit. Potentiometer R304 is an internal voltage adjustment. Resistor R307 serves as a current limit device.

b. -15 V Regulator. AC power is tapped from one secondary of transformer T301. The ac is rectified by a full-wave bridge rectifier (D302). Transistor Q302 is the series pass regulator. Integrated circuit QA-302 is a self-contained reference and regulating circuit. Potentiometer R309 is an internal voltage adjustment. Resistor R307 serves as a current limit device.

5-5. CURRENT SUPPRESSION CIRCUITRY (PC-290). The suppression is applied at the input as shown in Figure 15. The MAX AMPERES Switch (S303) sets the current suppression in decade steps from 10^{-3} to 10^{-10} amperes (Resistors R325 through R332). Potentiometer R333 is the FINE Control which provides adjustment from 0 to 1.5 times the MAX setting. Switch S304 sets the polarity (either + and - 15 volt source). Current suppression is a function of V_{CS}/R_{CS} ,

where V_{CS} = Voltage at the wiper of R333.

R_{CS} = Series Resistor (R325 through R332).

Example: If MAX AMPERES = 10^{-6}

and if V_{CS} = +15 V

then $I_{CS} = \frac{+15V}{10^7\Omega} = +1.5 \times 10^{-6}$ amperes

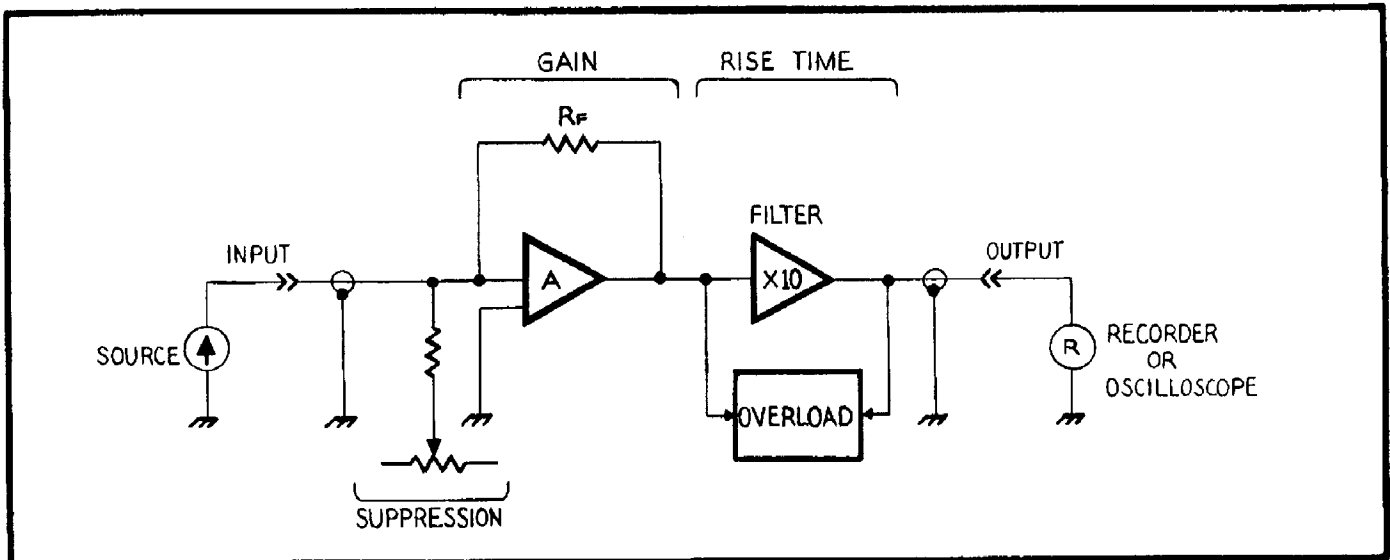

FIGURE 12. Block diagram of a high-speed current amplifier

17

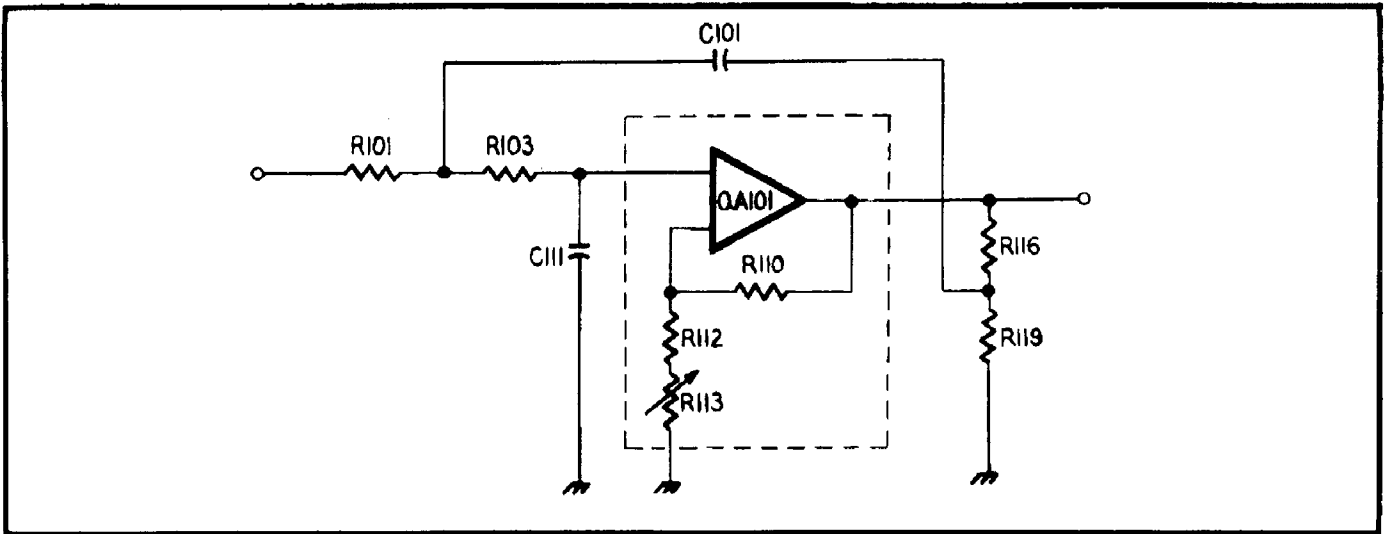

FIGURE 13. Filter Circuit.

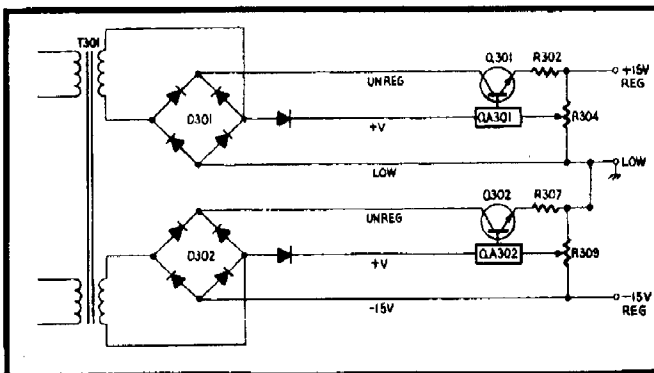

FIGURE 14. Power Supply Regulator.

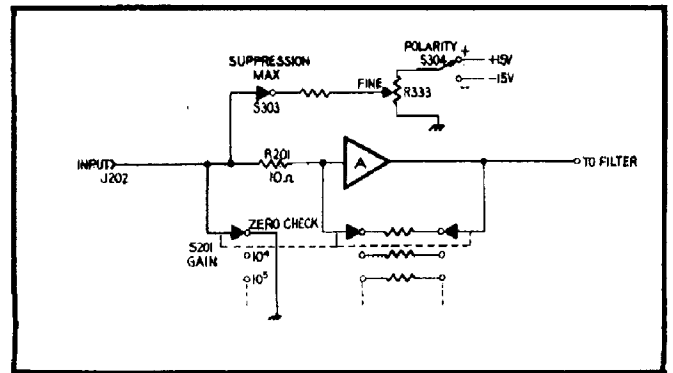

FIGURE 15. Current Suppression.

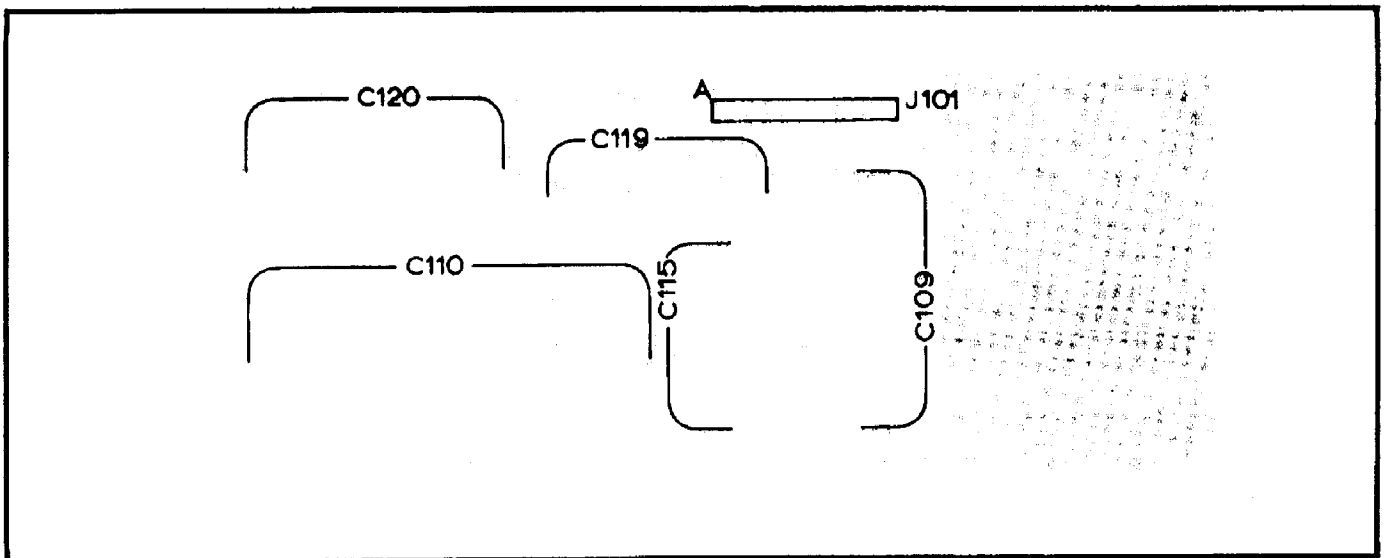

FIGURE 16. Component Layout - PC-291.

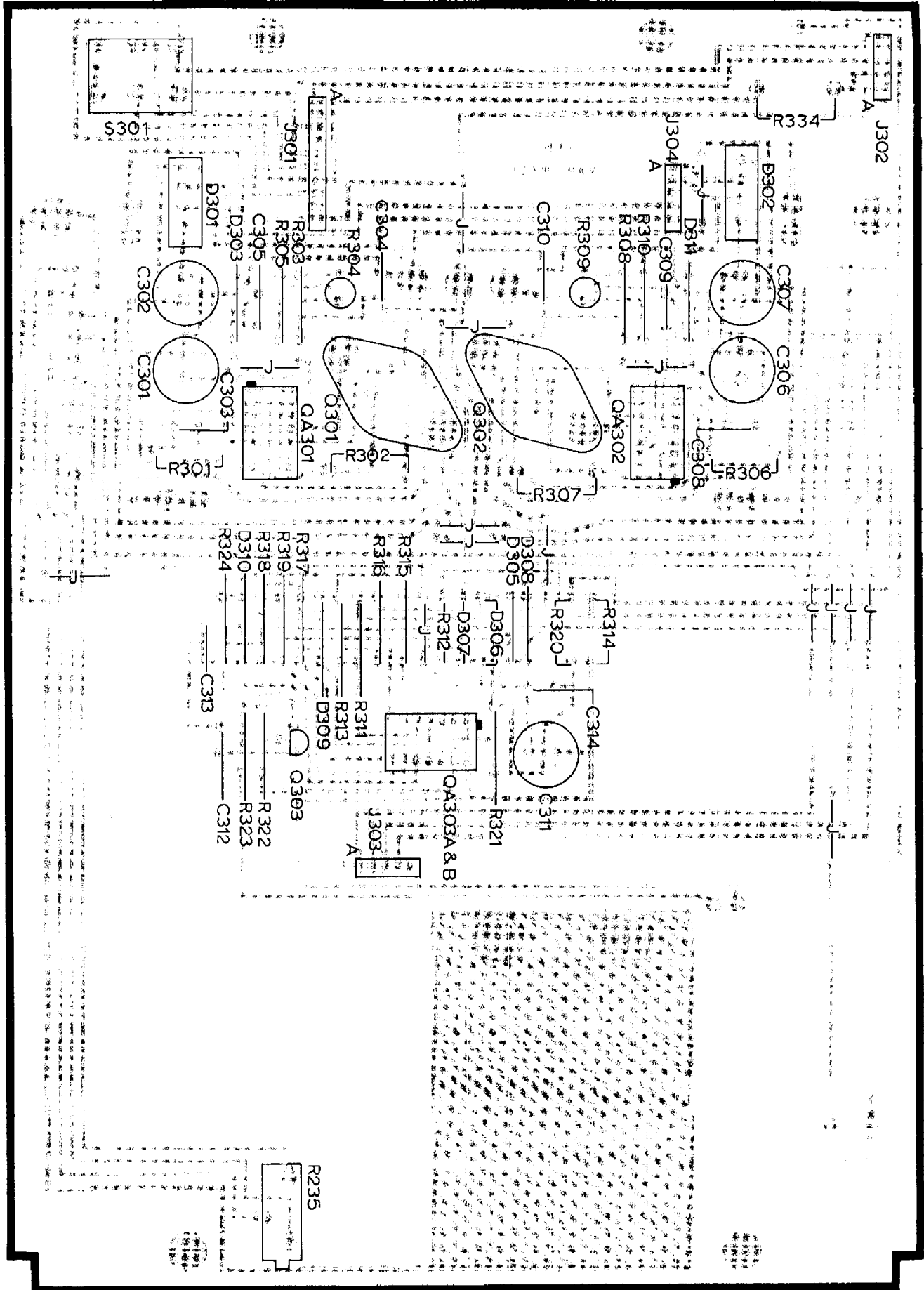

FIGURE 17. Component Layout - PC-290.

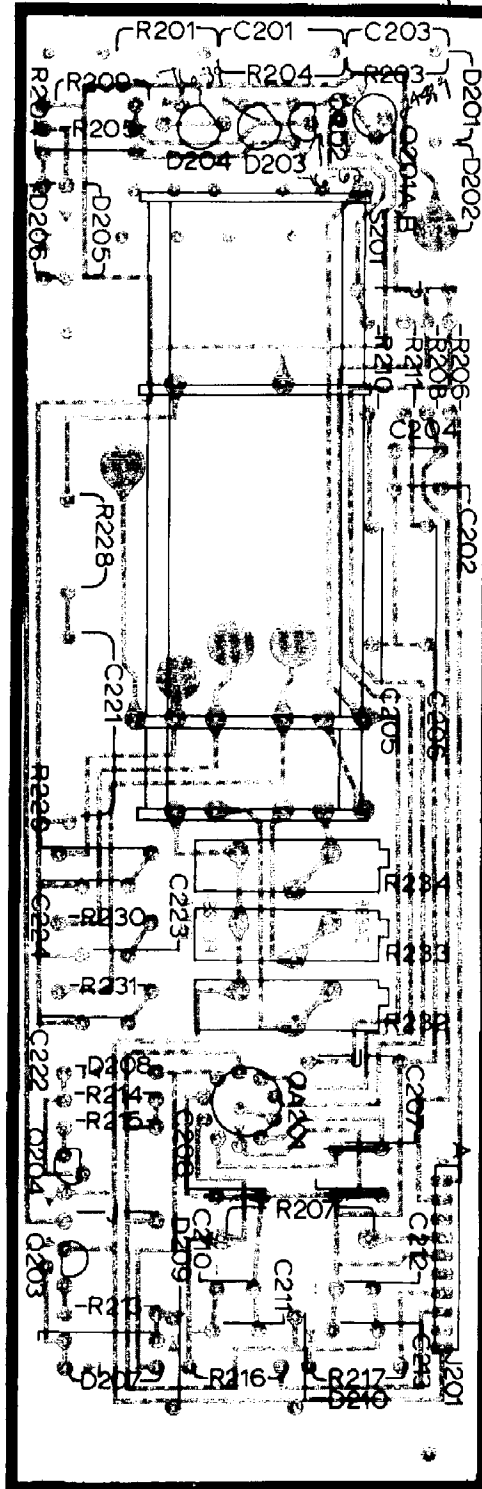
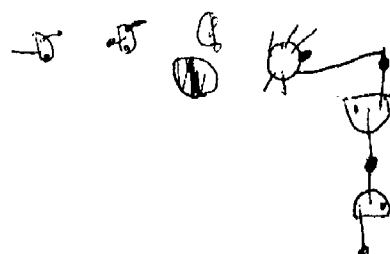

FIGURE 18.
Component Layout - PC-289.

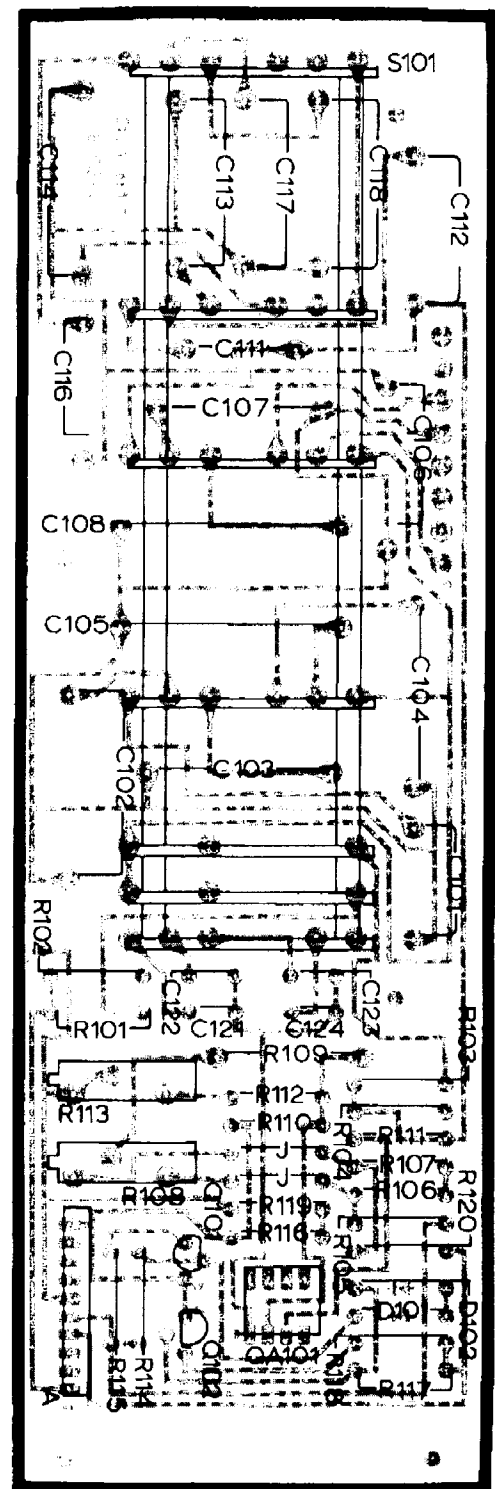

FIGURE 19.
Component Layout - PC-292.

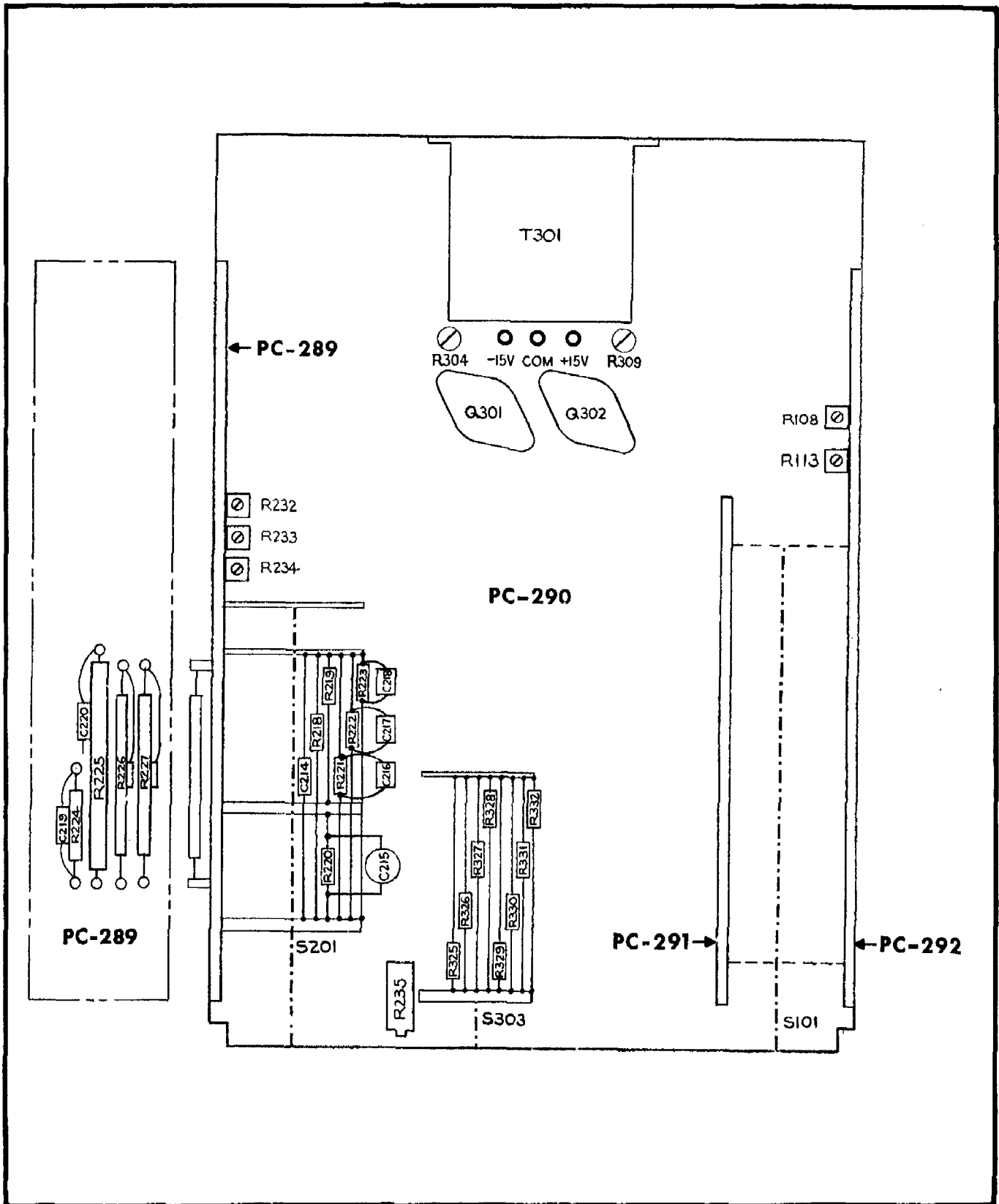

FIGURE 20. Chassis - Top View.

21

SECTION 6. REPLACEABLE PARTS

6-1. REPLACEABLE PARTS LIST: This section contains a list of components used in this instrument for user reference. The Replaceable Parts List describes the individual parts giving Circuit Designation, Description, Suggested Manufacturer (Code Number), Manufac-

turer's Part Number, and the Keithley Part Number. Also included is a Figure Reference Number where applicable. The complete name and address of each Manufacturer is listed in the CODE-TO-NAME Listing following the parts list.

TABLE 6-1.
Abbreviations and Symbols

A	ampere	F	farad	Ω	ohm
CbVar	Carbon Variable	Fig	Figure	p	pico (10 ⁻¹²)
CerD	Ceramic Disc	GCb	Glass enclosed Carbon	PC	Printed Circuit
CerTB	Ceramic Tubular	k	kilo (10 ³)	Poly	Polystyrene
Cer Trimmer	Ceramic Trimmer	μ	micro (10 ⁻⁶)	Ref.	Reference
Comp	Composition	M	Meg (10 ⁶)	TCu	Tinner Copperweld
DCb	Deposited Carbon	Mfr.	Manufacturer	V	volt
Desig.	Designation	MtF	Metal Film	W	watt
EAL	Electrolytic, Aluminum	My	Mylar	WW	Wirewound
ETB	Electrolytic, Tubular	No.	Number	WWVar	Wirewound Variable
ETT	Electrolytic, Tantalum				

6-2. ELECTRICAL SCHEMATICS AND DIAGRAMS. Schematics and diagrams are included to describe the electrical circuits as discussed in Section 5. Table 6-2 identifies all schematic part numbers included.

6-3. HOW TO USE THE REPLACEABLE PARTS LIST. This Parts List is arranged such that the individual types of components are listed in alphabetical order. Main Chassis parts are listed followed by printed circuit boards and other subassemblies.

6-4. HOW TO ORDER PARTS.

a. Replaceable parts may be ordered through the

Sales Service Department, Keithley Instruments, Inc. or your nearest Keithley representative.

b. When ordering parts, include the following information.

1. Instrument Model Number
2. Instrument Serial Number
3. Part Description
4. Schematic Circuit Designation
5. Keithley Part Number

c. All parts listed are maintained in Keithley Spare Parts Stock. Any part not listed can be made available upon request. Parts identified by the Keithley Manufacturing Code Number 80164 should be ordered directly from Keithley Instruments, Inc.

TABLE 6-2.
Electrical Schematics and Diagrams

Description	Circuit Designation	Schematic
Amplifier Board	PC-289	24766D
Mother Board (Power Supply)	PC-290	24768D
Filter Board	PC-291, PC-292	24767D

22

TABLE 6-3.
PC Board Designation Series

Series	Description	Designation	Page No.
100	Filter Circuit	PC-291	20
100	Filter Circuit	PC-292	20
200	Amplifier	PC-289	21
300	Power Supply	PC-290	23
300	Suppression Circuit	PC-290	23
300	Overload Circuit	PC-290	23

TABLE 6-4.
Mechanical Parts List

Item No.	Description	Qty. Per Assembly	Keithley Part No.	Figure No
-	Chassis Assembly	-	-	21
-	Front Panel Assembly	-	-	
1	Front Panel	1	24756C	
2	Screw, Slotted, 6-32 x 3/8	4	-	
3	Front Panel Overlay	1	24758B	
4	Rear Panel	1	24760B	
5	Side Extrusion Left	1	24754C	
6	Side Extrusion Right	1	24754C	
7	Corner Bracket	2	24745B	
8	Screw, Socket, 6-32 x 1/4	4	-	
9	Screw, Phillips, 6-32 x 1/4	4	-	
10	Clip for Side Dress	2	FA-101	
11	Side Dress Panel	2	24755B	
-	Top Cover Assembly	-	-	
12	Top Cover	1	24732C	
13	Screw, Socket, 6-32 x 5/16	4	-	
-	Bottom Cover Assembly	-	24763B	22
14	Bottom Cover	1	24733C	
15	Screw, Socket, 6-32 x 5/16	4	-	
-	Feet Assembly	-	-	
16	Feet	4	24322B	
17	Ball	4	FE-6	
18	Tilt Bail	1	17147B	
19	Screw, Phillips, 6-32	4	-	
20	Keq Nut, 6-32	4	-	

21 FA-102

WARNING

Using a Line Power Cord other than the one supplied with your instrument may result in an electrical shock hazard. If the Line Power cord is lost or damaged, replace only with Keithley Part No. CO-7.

Revised 6/04

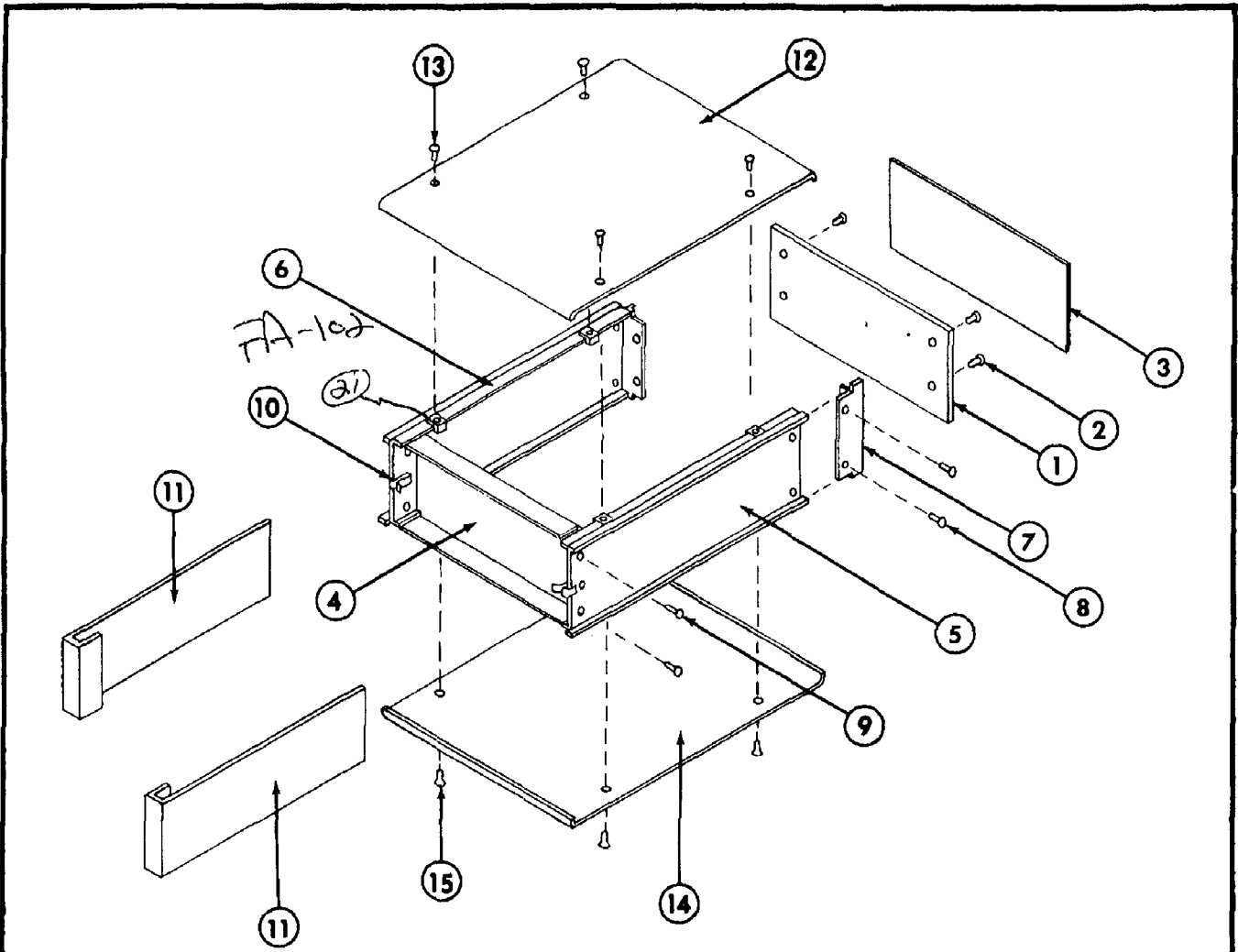

FIGURE 21. Chassis Assembly-Exploded View.

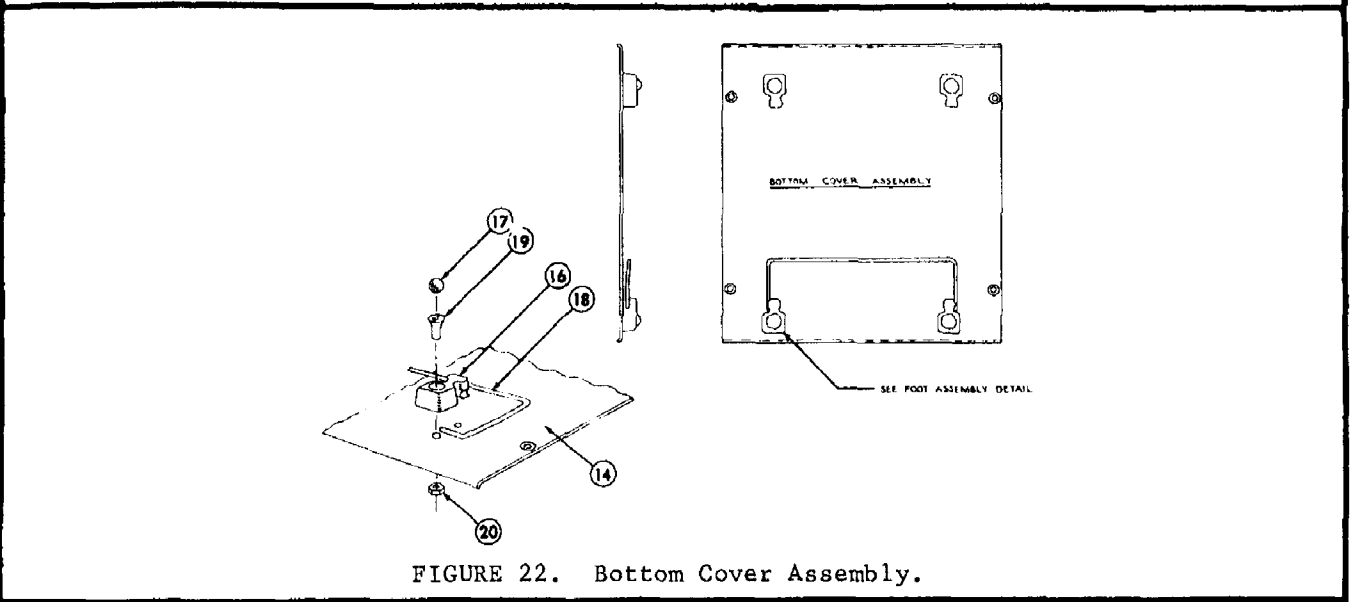

FIGURE 22. Bottom Cover Assembly.

24

FILTER BOARD
("100" SERIES, PC-291*, PC-292)

CAPACITORS

Circuit Desig.	Value	Rating	Type	Mfr. Code	Mfr. Desig.	Keithley Part No.	Fig. Ref.
C101	150 pF	500 V	Poly	71590	CPR-150J	C138-150P	19
C102	680 pF	500 V	Poly	71590	CPR-680J	C138-680P	19
C103	.0022 μ F	500 V	Poly	71590	CPR-2200J	C138-.0022M	19
C104	6800 pF	500 V	Poly	71590	CPR-6800J	C138-6800P	19
C105	.022 μ F	200 V	Poly	84171	2PJ-223G	C108-.022M	19
C106	.068 μ F	100 V	My	88480	3FR-683-1E	C146-.068M	19
C107	.22 μ F	200 V	My	13050	SMA-.22 μ F	C47-.22M	19
C108	.68 μ F	200 V	My	13050	SMA-.68 μ F	C47-.68M	19
C109*	2.2 μ F	200 V	My	13050	SMA-2.2 μ F	C47-2.2M	16
C110*	6.8 μ F	200 V	My	97419	M2WF-6.8 μ F	C203-6.8M	16
C111	68 pF	500 V	Poly	71590	CPR-68J	C138-68P	19
C112	330 pF	500 V	Poly	71590	CPR-330J	C138-330P	19
C113	.001 μ F	500 V	Poly	71590	CPR-1000J	C138-.001M	19
C114	.0033 μ F	500 V	Poly	71590	CPR-3300J	C138-.0033M	19
C115*	.01 μ F	200 V	Poly	84171	2PJ-103G	C108-.01M	16
C116	.033 μ F	100 V	My	88480	3FR-333-1E	C146-.033M	19
C117	.1 μ F	200 V	My	13050	SMA-.1 μ F	C47-.1M	19
C118	.33 μ F	200 V	My	13050	SMA-.33 μ F	C47-.33M	19
C119*	1 μ F	200 V	My	13050	SMA-1 μ F	C47-1M	16
C120*	3.3 μ F	200 V	My	13050	SMA-3.3 μ F	C47-3.3M	16
C121	5 pF	1000 V	CerD	72982	DD-050	C64-5P	19
C122	5 pF	1000 V	CerD	72982	DD-050	C64-5P	19
C123	33 pF	1000 V	CerD	72982	DD-330	C64-33P	19
C124	100 pF	100 V	CerD	72982	DD-101	C64-100P	19

MISCELLANEOUS

Circuit Desig.	Type	Mfr. Code	Mfr. Desig.	Keithley Part No.	Fig. Ref.
J101	Connector, 10-Pin, Mini-PV	22526	20052	CS-237	19
QA101	Integrated Circuit	12040	LM301AN	IC-24	19
D101	Diode, Rectifier	01295	1N914	RF-28	19
D102	Diode, Rectifier	01295	1N914	RF-28	19
Q101	Transistor	04713	2N3903	TG-49	19
Q102	Transistor	04713	2N3905	TG-53	19
S101	Switch, Rotary, RISE TIME	80164	SW-338	SW-338	19
J102	Connector, BNC, UG1094A/U			CS-249	3
--	Cap, BNC, mates with J102	02660	31-2221	CAP-18	-

RESISTORS

Circuit Desig.	Value	Rating	Type	Mfr. Code	Mfr. Desig.	Keithley Part No.	Fig. Ref.
R101	7.78 k Ω	1%, 1/8 W	MtF	07716	CEA-7.78K Ω	R88-7.78k	19
R102	8.41 k Ω	1%, 1/8 W	MtF	07716	CEA-8.41K Ω	R88-8.41k	19
R103	51.7 k Ω	1%, 1/8 W	MtF	07716	CEA-51.7K Ω	R88-51.7k	19
R104	51.7 k Ω	1%, 1/8 W	MtF	07716	CEA-51.7K Ω	R88-51.7k	19
R105	10 k Ω	1%, 1/8 W	MtF	07716	CEA-10K Ω	R88-10k	19

25

FILTER BOARD (cont'd)
RESISTORS (cont'd)

Circuit Desig.	Value	Rating	Type	Mfr. Code	Mfr. Desig.	Keithley Part No.	Fig. Ref.
R106	1 kΩ	1%, 1/8 W	MtF	07716	CEA-1kΩ	R88-1k	19
R107	1 kΩ	1%, 1/8 W	MtF	07716	CEA-1kΩ	R88-1k	19
R108	200 Ω	.75 W	Comp	80294	3009P-200	RP-89-200	19
R109	1 MΩ	.1%, 1/2 W	MtF	91637	MFF-1MΩ	R169-1M	19
R110	536 kΩ	.1%, 1/2 W	MtF	91637	MFF-536Ω	R168-536k	19
R111	1 kΩ	10%, 1/4 W	Comp	44655	RC07-102	R76-1k	19
R112	61.9 kΩ	.1%, 1/8 W	MtF	91637	MFF-61.9kΩ	R168-61.9k	19
R113	2 kΩ	.75 W	Comp	80294	3009P-2k	RP-89-2k	19
R114	10 kΩ	1%, 1/8 W	MtF	07716	CEA-10kΩ	R88-10k	19
R115	470 Ω	10%, 1/4 W	Comp	44655	RC07-471	R76-470	19
R116	1.8 kΩ	1%, 1/8 W	MtF	07716	CEA-1.8kΩ	R88-1.8k	19
R117	10 kΩ	1%, 1/8 W	MtF	07716	CEA-10kΩ	R88-10k	19
R118	470 Ω	10%, 1/8 W	Comp	44655	RC07-471	R76-470	19
R119	200 Ω	1%, 1/8 W	MtF	07716	CEA-200Ω	R88-200	19
R120	10 kΩ	1%, 1/8 W	MtF	07716	CEA-10kΩ	R88-10k	19

AMPLIFIER BOARD
("200" SERIES, PC-289)

CAPACITORS (* Located on Switch S201.)

Circuit Desig.	Value	Rating	Type	Mfr. Code	Mfr. Desig.	Keithley Part No.	Fig. Ref.
C201	.0022 μF	1000 V	CerD	72982	10SS-D22	C22-.0022M	18
C202	.001 μF	1000 V	CerD	72982	801000X5F0102K	C64-.001M	18
C203	1.5 pF	600 V	CerT	71590	TCZ-1R5	C77-1.5P	18
C204	.001 μF	1000 V	CerD	72982	801000X5F0102K	C64-.001M	18
C205	.047 μF	200 V	My	13050	SM2A-.047μF	C143-.047M	18
C206	.047 μF	200 V	My	13050	SM2A-.047μF	C143-.047M	18
C207	470 pF	1000 V	CerD	72982	DD471	C64-470P	18
C208	.0022 μF	1000 V	CerD	72982	10SS-D22	C22-.0022M	18
C209	.001 μF	1000 V	CerD	72982	801000X5F0102K	C64-.001M	18
C210	10 μF	20 V	ETT	17554	TSD1-20-10μF	C179-10M	18
C211	.001 μF	1000 V	CerD	72982	801000X5F0102K	C64-.001M	18
C212	10 μF	20 V	ETT	17554	TSD1-20-10μF	C179-10M	18
C213	.001 μF	1000 V	CerD	72982	801000X5F0102K	C64-.001M	18
* C214	.0047 μF**	200 V	MMT	97419	-	C66-.0047M**	20
* C215	.0047 μF	1000 V	CerD	56289	10SS-D47	C22-.0047M	20
* C216	470 pF	500 V	Poly	71590	CPR-470J	C138-470P	20
* C217	47 pF	500 V	Poly	71590	CPR-47J	C138-47P	20
* C218	5 pF	200 V	Poly	00686	E1013-1-5pF	C31-5P	20
C219	1.5 pF	600 V	CerT	71590	TCZ-1R5	C77-1.5P	20
C220	1.5 pF	600 V	CerT	71590	TCZ-1R5	C77-1.5P	20
C221	.033 μF	100 V	My	88480	3FR333-1E	C146-.003M	18
C222	.001 μF	1000 V	CerD	72982	801000X5F0102K	C64-.001M	18
C223	.0033 μF	1000 V	CerD	56289	10SS-D33	C22-.0033M	18
C224	.0033 μF	1000 V	CerD	56289	10SS-D33	C22-.0033M	18

**Nominal Value, Selected in Factory Test

210

AMPLIFIER BOARD (cont'd)
DIODES

Circuit Desig.	Type	Mfr. Code	Mfr. Desig.	Keithley Part No.	Fig. Ref.
D201	Special	80164	24555A	24555A 28569	18
D202	Special	80164	24555A	24555A	18
D203	Silicon, NPN, Case TO-106	07263	2N3565	TG-39	18
D204	Silicon, NPN, Case TO-106	07263	2N3565	TG-39	18
D205	-	01295	1N645	RF-14	18
D206	-	01295	1N645	RF-14	18
D207	Silicon	01295	1N914	RF-28	18
D208	Silicon	01295	1N914	RF-28	18
D209	Silicon	01295	1N914	RF-28	18
D210	Silicon	01295	1N914	RF-28	18

MISCELLANEOUS

Circuit Desig.	Type	Mfr. Code	Mfr. Desig.	Keithley Part No.	Fig. Ref.
QA201	Integrated Circuit, Operational Amplifier	07263	μA715C	IC-26	18
S201	Switch, Rotary, GAIN	80164	SW-337	SW-337	18
J201	Not Used				18
J202	Receptacle, BNC (UG-1094A/U)	02660	31-2221	CS-249	18

RESISTORS (* Located on Switch S201.)

Circuit Desig.	Value	Rating	Type	Mfr. Code	Mfr. Desig.	Keithley Part No.	Fig. Ref.
R201	10 Ω	10%, 1/4 W	Comp	44655	RC07	R76-10	18
R202	1 MΩ	10%, 1/2 W	Comp	01121	EB-1M	R1-1M	18
R203	100 kΩ	1%, 1/8 W	MtF	07716	CEA-100kΩ	R88-100k	18
R204	23.2 kΩ	1%, 1/8 W	MtF	07716	CEA-23.2kΩ	R88-23.2k	18
R205	22.1 kΩ	1%, 1/8 W	MtF	07716	CEA-22.1kΩ	R88-22.1k	18
R206	10 kΩ	1%, 1/8 W	MtF	07716	CEA-10kΩ	R88-10k	18
R207	18.2 kΩ	1%, 1/2 W	MtF	07716	CEC-18.2kΩ	R94-18.2k	18
R208	10 kΩ	1%, 1/8 W	MtF	07716	CEA-10kΩ	R88-10k	18
R209	12.1 kΩ	1%, 1/8 W	MtF	07716	CEA-12.1kΩ	R88-12.1k	18
R210	499 Ω	1%, 1/8 W	MtF	07716	CEA-499Ω	R88-499 3.01k	18
R211	499 Ω	1%, 1/8 W	MtF	07716	CEA-499Ω	R88-499 3.01k	18
R212	10 Ω	1%, 1/8 W	MtF	07716	CEA-10Ω	R88-10	18
R213	470 Ω	10%, 1/4 W	Comp	44655	RC07-471	R76-470	18
R214	10 kΩ	1%, 1/8 W	MtF	07716	CEA-10kΩ	R88-10k	18
R215	470 Ω	10%, 1/4 W	Comp	44655	RC07-471	R76-470	18
R216	10 Ω	10%, 1/4 W	Comp	44655	RC07-100	R76-10	18
R217	10 Ω	10%, 1/4 W	Comp	44655	RC07-100	R76-10	18
* R218	270 kΩ	10%, 1/2 W	Comp	01121	EB-270kΩ	R1-270k	20
* R219	100 Ω	1%, 1/2 W	MtF	07716	CEC-100Ω	R94-100	20
* R220	900 Ω	1%, 1/2 W	DCb	91637	DCF-1/2-900Ω	R12-900	20
* R221	10 kΩ	1%, 1/2 W	MtF	07716	CEC-10kΩ	R94-10k	20
* R222	100 kΩ	1%, 1/2 W	MtF	07716	CEC-100kΩ	R94-100k	20
* R223	1 MΩ	1%, 1/2 W	MtF	07716	CEC-1MΩ	R94-1M	20
R224	10 MΩ	1%, 1 W	DCb	91637	DC-1-10MΩ	R13-10M	20
R225	10 ⁸ Ω	1%, 2 W	DCb	91637	DC-2-10 ⁸ Ω	R14-10 ⁸ R287-1000	20

27

AMPLIFIER BOARD (cont'd)
RESISTORS (cont'd)

Circuit Desig.	Value	Rating	Type	Mfr. Code	Mfr. Desig.	Keithley Part No.	Fig. Ref.
R226	10 ⁹ Ω	-	Gcb	63060	RX-1-10 ⁹	R20-10 ⁹	20
R227	10 ¹⁰ Ω	-	Gcb	63060	RX-1-10 ¹⁰	R20-10 ¹⁰	20
R228	*15 Ω	10%, 1/4 W	Comp	44655	RC07-150	R76-15	18
R229	10 kΩ	10%, 1/4 W	Comp	44655	RC07-103	R76-10k	18
R230	220 kΩ	10%, 1/4 W	Comp	44655	RC07-224	R76-220k	18
R231	330 kΩ	10%, 1/4 W	Comp	44655	RC07-334	R76-330k	18
R232	100 kΩ	1/2 W	CbVar	80294	3068P-100k	RP89-100k	18
R233	1 MΩ	1/2 W	CbVar	80294	3068P-1M	RP89-1M	18
R234	1 MΩ	1/2 W	CbVar	80294	3068P-1M	RP89-1M	18
R235	500 Ω	Potentiometer		Hellipot	77PR500	RP-64-500	

*Nominal value, selected in test.

TRANSISTORS

Circuit Desig.	Type	Mfr. Code	Mfr. Desig.	Keithley Part No.	Fig. Ref.
Q201	Dual, FET, Case TO-71	80164	2N5452	25099A*	18
Q202	Silicon, NPN, Case TO-92	04713	2N5089	TG-62	18
Q203	Silicon, NPN, Case TO-92	04713	2N3903	TG-49	18
Q204	PNP, Case TO-92	04713	2N3905	TG-53	18

*Selected TG-70

MOTHER BOARD PARTS LIST
("300" SERIES, PC-290)

CAPACITORS

Circuit Desig.	Value	Rating	Type	Mfr. Code	Mfr. Desig.	Keithley Part No.	Fig. Ref.
C301	200 μF	35 V	EAL	90201	MTV-200μF	C177-200M	17
C302	200 μF	35 V	EAL	90201	MTV-200μF	C177-200M	17
C303	10 μF	20 V	ETT	17554	TSD1-20-10μF	C179-10M	17
C304	10 μF	20 V	ETT	17554	TSD1-20-10μF	C179-10M	17
C305	2200pF	1000 V	CerD	72982	DD-222	C64-2200P	17
C306	200 μF	35 V	EAL	90201	MTV-200μF	C177-200M	17
C307	200 μF	35 V	EAL	90201	MTV-200μF	C177-200M	17
C308	10 μF	20 V	ETT	17554	TSD1-20-10μF	C179-10M	17
C309	2200pF	1000 V	CerD	72982	DD-222	C64-2200P	17
C310	10 μF	20 V	ETT	17554	TSD1-20-10μF	C179-10M	17
C311	200 μF	35 V	EAL	90201	MTV-200μF	C177-200M	17
C312	10 μF	20 V	ETT	17554	TSD1-20-10μF	C179-10M	17
C313	.47 μF	20 V	ETT	17554	TSD1-20-.47μF	C179-.47M	17
C314	10 μF	20 V	ETT	17554	TSD1-20-10μF	C179-10M	17
C315	0.01μF	500 V	CerD	ERIE	871-25U0-103M	C22-.01M	17

DIODES

Circuit Desig.	Type	Mfr. Code	Mfr. Desig.	Keithley Part No.	Fig. Ref.
D301	Four Diode Bridge	83701	PD-10	RF-36	17
D302	Four Diode Bridge	83701	PD-10	RF-36	17
D303	Silicon	01295	1N645	RF-14	17
D304	Not Used	--	--	--	--
D305	Silicon	01295	1N914	RF-28	17
D306	Silicon	01295	1N914	RF-28	17
D307	Silicon	01295	1N914	RF-28	17

Change to ~~871-25U0~~ (C-308-220)

28

MOTHER BOARD (cont'd)
DIODES (cont'd)

Circuit Desig.	Type	Mfr. Code	Mfr. Desig.	Keithley Part No.	Fig. Ref.
D308	Silicon	01295	1N914	RF-28	17
D309	Silicon	01295	1N914	RF-28	17
D310	Silicon	01295	1N914	RF-28	17
D311	Silicon	01295	1N645	RF-14	17
D312	Silicon	01295	1N914	RF-28	--

MISCELLANEOUS

Circuit Desig.	Type	Mfr. Code	Mfr. Desig.	Keithley Part No.	Fig. Ref.
J301	Connector, Mini-PV	22526	47439	CS-236	17
J302	Connector, Mini-PV	22526	47439	CS-236	17
QA301	Integrated Circuit, Voltage Regulator	07263	UGA7723393	IC-25	17
QA302	Integrated Circuit, Voltage Regulator	07263	UGA7723393	IC-25	17
QA303	Integrated Circuit	07263	A749C	IC-27	17
S301	Switch, Line Voltage	80164	SW-318	SW-318	3
S302	Switch, "PUSH ON" Power with lamp	80164	PBL-5-BSA3C7A	SW-340	3
S303	Switch, CURRENT SUPPRESS	80164	SW-339	SW-339	20
Q301	Transistor	02735	40312	TG-54	17
Q302	Transistor	02735	40312	TG-54	17
Q303	Transistor, Silicon, NPN, TO-92 Case	04713	2N3903	TG-49	17
S304	Switch, POLARITY	80164	SW-236	SW-236	3
F301	Fuse, 117V, .25A, Slo-Blo, 3 AG	75915	313.250	FU-17	3
F301	Fuse, 234V, 1/8A, Slo-Blo, 3 AG	71400	MDL	FU-20	3
T301	Transformer	80164	TR-138	TR-138	20
P305	Receptacle, AC	82389	AC3G	CS-235	3
--	Line cord, mates with P305	70903	17258-S	CO-7	--
DS-301	Pilot lamp, neon (replacement for S302)	08806	C7A(NE-2P)	PL-58	--
DS-302	Pilot Lamp, OVERLOAD	07294	CF03ACS1869	PL-51	2

RESISTORS (*Located on Switch S303.)

Circuit Desig.	Value	Rating	Type	Mfr. Code	Mfr. Desig.	Keithley Part No.	Fig. Ref.
R301	634 Ω	1%, 1/8 W	MtF	07716	CEA-634 Ω	R88-634	17
R302	8.2 Ω	5%, 1/2 W	Comp	01121	EB-8.2 Ω	R19-8.2	17
R303	1.37 k Ω	1%, 1/8 W	MtF	07716	CEA-1.37k Ω	R88-1.37k	17
R304	200 Ω	0.5 W	-	80294	3329P-200	RP-88-200	17
R305	1.24 k Ω	1%, 1/8 W	MtF	07716	CEA-1.1k Ω	R88-1.24	17
R306	634 Ω	1%, 1/8 W	MtF	07716	CEA-634 Ω	R88-634	17
R307	8.2 Ω	5%, 1/2 W	Comp	01121	EB-8.2 Ω	R19-8.2	17
R308	1.37 k Ω	1%, 1/8 W	MtF	07716	CEA-1.37k Ω	R88-1.371	17
R309	200 Ω	0.5 W	-	80294	3329P-200	RP-98-200	17
R310	1.24 k Ω	1%, 1/8 W	MtF	07716	CEA-1.1k Ω	R88-1.24	17
R311	9.09 k Ω	1%, 1/8 W	MtF	07716	CEA-9.09k Ω	R88-9.09k	17
R312	14 k Ω	1%, 1/8 W	MtF	07716	CEA-14k Ω	R88-14k	17
R313	1 k Ω	1%, 1/8 W	MtF	07716	CEA-1k Ω	R88-1k	17
R314	10 Ω	10%, 1/4 W	Comp	44655	RC07-100	R76-10	17
R315	1 k Ω	1%, 1/8 W	MtF	07716	CEA-1k Ω	R88-1k	17
R316	9.09 k Ω	1%, 1/8 W	MtF	07716	CEA-9.09k Ω	R88-9.09k	17
R317	1 k Ω	1%, 1/8 W	MtF	07716	CEA-1k Ω	R88-1k	17
R318	1 k Ω	1%, 1/8 W	MtF	07716	CEA-1k Ω	R88-1k	17
R319	14 k Ω	1%, 1/8 W	MtF	07716	CEA-14k Ω	R88-14k	17
R320	10 Ω	10%, 1/4 W	Comp	44655	RC07-100	R76-10	17
R321	10 k Ω	10%, 1/4 W	Comp	44655	RC07-103	R76-10k	17
R322	10 k Ω	10%, 1/4 W	Comp	44655	RC07-103	R76-10k	17
R323	330 Ω	10%, 1/4 W	Comp	44655	RC07-331	R76-330	17
R324	47 k Ω	10%, 1/4 W	Comp	44655	RC07-473	R76-47k	17
*R325	10 k Ω	1%, 1/2 W	MtF	07716	CEC -10k Ω	R94-10k	20

29

MOTHER BOARD (cont'd)
RESISTORS (cont'd)

Circuit Desig.	Value	Rating	Type	Mfr. Code	Mfr. Desig.	Keithley Part No.	Fig. Ref.
* R326	100 kΩ	1%, 1/2 W	MtF	07716	CEC-100kΩ	R94-100k	20
* R327	1 MΩ	1%, 1/2 W	MtF	07716	CEC-1MΩ	R94-1M	20
* R328	10 MΩ	1%, 1 W	DCb	91637	DC-1-10MΩ	R13-10M	20
* R329	100 MΩ	1%, 2 W	DCb	91637	DC-2-100MΩ	R14-100M R287-10M	20
* R330	10 ⁹ Ω	-	GCb	63060	RX-1-10 ⁹ Ω	R20-10⁹ R287-16	20
* R331	10 ¹⁰ Ω	-	GCb	63060	RX-1-10 ¹⁰ Ω	R20-10 ¹⁰ R287-106	20
* R332	10 ¹¹ Ω	-	GCb	63060	RX-1-10 ¹¹ Ω	R20-10¹¹ R287-106	20
R333	10 kΩ	2 W	WW	12697	62JA-10kΩ	RP-92-10k	17
R334	33 kΩ	10%, 1/2 W	Comp	01121	EB-33k Ω	R1-33k	17
R335	68 kΩ	10%, 1/4 W	Comp	44655	RC07-683	R76-68k	--

30

SECTION 7. CALIBRATION

7-1. GENERAL. This section contains procedures for checking the instrument to verify operation within specifications. The procedures and adjustments should be performed in the exact sequence given to obtain satisfactory results.

7-2. TEST EQUIPMENT. Use the test equipment specified in Table 7-1. Equivalent instruments may be substituted provided the accuracy tolerances are equal to or better than the equipment specified.

NOTE

The Suppression Max. Amperes switch will be left in the OFF position unless stated otherwise.

7-3. PROCEDURES.

a. Preliminary Calibration.

1. Power Supplies.

a). Connect Model 163 between the +15 volt test point and chassis and adjust the +15 volt potentiometer R309 for +15 volts ± 10 mV. Using the oscilloscope check for less than 1 mV peak-to-peak ripple.

b). Connect Model 163 between the -15 volt test point and chassis and adjust the -15 volt potentiometer R304 for -15 volts ± 10 mV. Check for less than 1 mV peak-to-peak ripple.

2. Line Regulation.

a). Plug the Model 427 line cord in to a Variac with Line Monitor.

b). Check the ± 15 volt supplies with the Variac adjusted for 90 and 125 volts. The voltages should be $\pm 15V \pm 20$ mV with less than 1 mV peak-to-peak ripple.

3. 234 Volt Operation.

a). Set the 117-234 volt switch to the 234 volt position and plug the 427 line cord into the 234 volt line.

b). Check the ± 15 volt supplies. They should read ± 15 volts ± 10 mV with less than 1 mV peak-to-peak ripple.

4. Overload Circuit Check.

a). Connect Model 163 to the Model 427 output. Set the Model 163 to the 10 volt range.

b). Set the Model 427 controls as follows:

GAIN: 10^6 volts/amperes
 SUPPRESSION: (-) 10^{-5} amperes
 RISE TIME: 300 ms

c). Turn the Suppression Fine control to obtain a reading of approximately +9.5 V on the Model 163. The Model 427 overload light should be off.

TABLE 7-1.
Test Equipment

Instrument Type	Specification	Mfr. and Model No.
Picoampere Source	10^{-14} to 1.1×10^{-4} A	Keithley, Model 261
Digital Voltmeter	$\pm 1 \mu V$ to 1000V, 0.1% of reading	Keithley, Model 163
Oscilloscope	--	Tektronix, Model 504 or 561B
Function Generator	--	Wavetek, Model 111 or 130
Microvolt-Ammeter	$10 \mu V$ to 1000V, 10^{-11} to 10^{-1} A	Keithley, Model 153
Variable Transformer	90-140V rms, 50-60 Hz	Variac
Line Voltage Monitor	90-140V rms, 50-60 Hz	--
True RMS VTVM	--	Ballantine, Model 320

211055
H. O. S.

31

d). Slowly turn the Suppression Fine control CW until the overload light comes on. This should occur between +10 and +11 volts.

e). Set the Model 427 Suppression Polarity switch to (+) and repeat steps c and d. Readings on the DVM will now be negative.

5. Current Amplifier Zero.

a). Set the Model 427 gain switch to zero check, suppression to OFF and Rise Time to 300 ms.

b). Turn the 427 front panel zero control cw until overload light comes on. Then very slowly turn the zero control cw until light goes off. Continue turning control cw until light comes on again. Then slowly turn control ccw and set in region where overload light stays off.

6. Filter Amplifier Zero and Gain.

a). Set the Model 427 gain to 10^4 V/A and Rise Time to 300 ms. Connect the Model 163 DVM to the Model 427 output. Set the Filter Amplifier zero pot (R108) for $0 \pm 1\text{mV}$ at the Model 427 output.

b). Set the 427 Gain to 10^5 V/A and connect a DVM (1V range) to the output of the first stage amplifier (QA201, Q203, Q204) at location on PC-290 (mother board) at jumper found directly below potentiometers R232 and R233. Set the Suppression to

10^4 amperes and adjust the front panel pot R333 for a reading of 1.000V. Connect DVM (10V range) to output of 427 and adjust Filter Amplifier gain pot (R113) for a reading of 10.00 volts.

c. Zero Supp
7. Input Voltage Drop.

a). Set the Model 261 to 10^{-6} ampere and the Model 427 gain to 10^7 V/A and connect the test set up as shown in Figure 23 using a BNC TEE connector on the Model 427 input.

b). With no input connected set up, the Model 153 for CENTER ZERO and VOLT R-2M. Zero on the $100 \mu\text{V}$ range then set the range to 1 mV.

c). With the Model 261 output OFF increase the Model 153 sensitivity to $300 \mu\text{V}$ range while maintaining a "0" indication on the Model 153 using the Model 427 front panel zero control. Correct drift with the Model 427 zero control as needed during checks.

d). Switch the Model 261 between OFF and (+) as needed to obtain a steady reading on the Model 153. The reading should be less than $-300 \mu\text{V}$.

e). Repeat step d but switch between OFF and (-) on the Model 261. The reading should be less than $+300 \mu\text{V}$. Re-zero the Model 427.

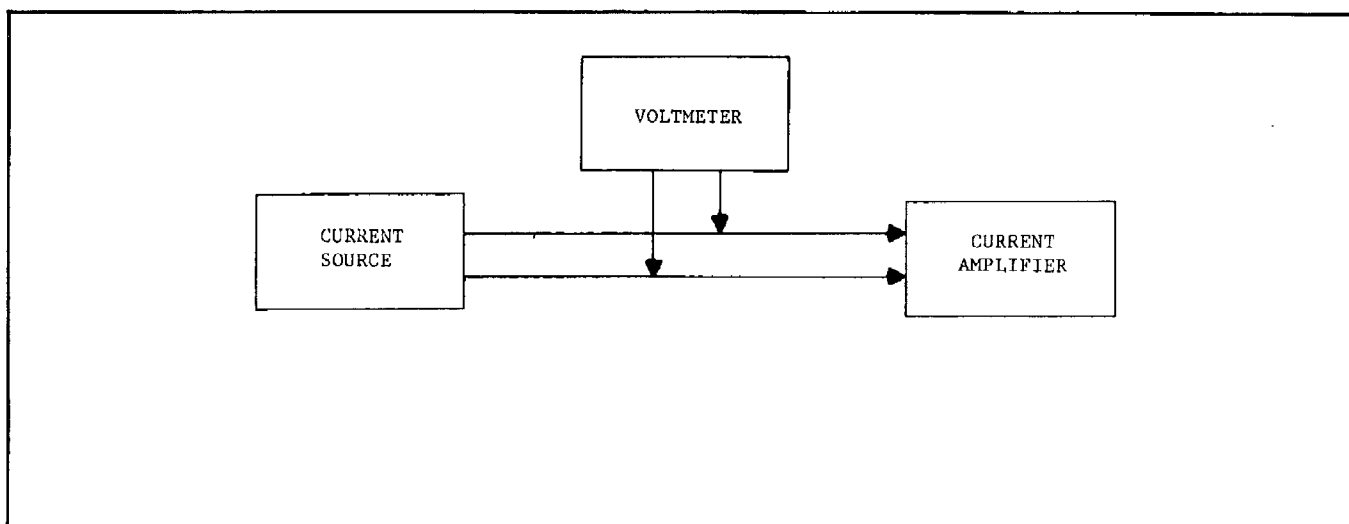

FIGURE 23. Measurement of Input Voltage Drop.

32

TABLE 7-2.

427 GAIN V/A	427 RISE TIME	WAVETEK FREQUENCY	MAX 10-90% RISE TIME	RISE TIME ADJUSTMENT
10 ¹¹	1.0 ms	100 Hz	1.50 ms	Slider & Pot
10 ¹⁰	.3 ms	500 Hz	0.40 ms	Slider & Pot
10 ⁹	.1 ms	1 kHz	0.22 ms	Pot
10 ⁸	.03 ms	2 kHz	0.60 ms	None
10 ⁷	.03 ms	10 kHz	0.40 ms	None
10 ⁶	.01 ms	10 kHz	0.015 ms	None
10 ⁵	.01 ms	10 kHz	0.015 ms	None
10 ⁴	.01 ms	10 kHz	0.015 ms	None

8. Amplifier Rise Time.

a). Connect Function Generator to the Model 427 input and connect the Model 427 rear panel output to the Oscilloscope using the test set up shown in Figure 24.

b). Adjust the 10⁹ through 10¹¹ ranges within the specified 10% to 90% rise time using the triangular wave frequency and adjustment listed in the table. Adjust the Function Generator as needed to obtain a 10 volt peak-to-peak output from the Model 427. Check the 10⁴ through 10⁸ ranges for the specified rise times. There should be no overshoot on any of the ranges.

9. Amplifier Noise.

a). Connect a 100pF capacitor between Model 427 input high and ground.

b). Connect the TRMS VTVM to the Model 427 rear panel output and check the Model 427 RMS output noise for all settings in Table 7-3.

10. Filter Rise Time.

a). Set the oscilloscope controls as follows:

VERTICAL INPUT: 2V/Div.
 COUPLING: DC
 TRIGGER: Ext.
 COUPLING: AC

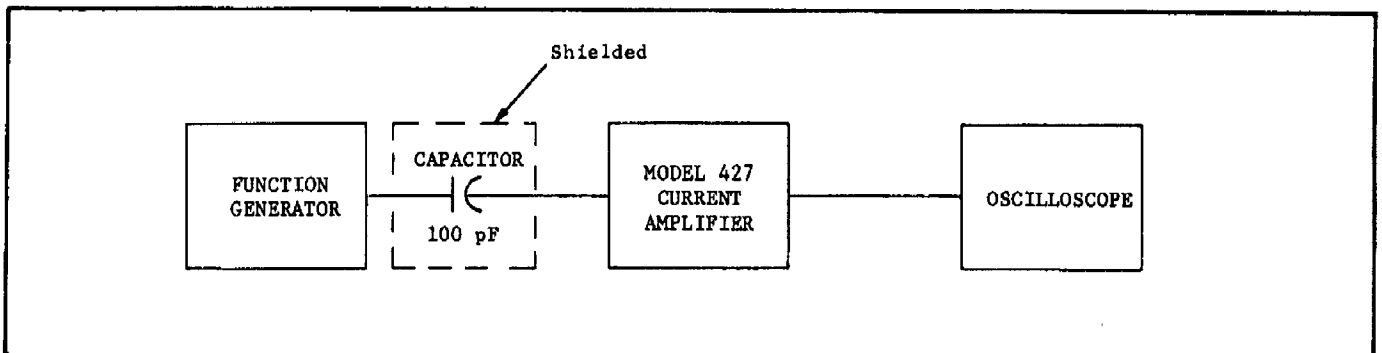

FIGURE 24. Measurement of Rise Time.

TABLE 7-3.

GAIN V/A (427)	RISE TIME (427)	TRUE RMS VTVM	MAX. RMS NOISE
10 ¹¹	1.0 ms	100 mV	40 mV
10 ¹⁰	.3 ms	30 mV	20 mV
10 ⁹	.1 ms	10 mV	10 mV
10 ⁷	.03 ms	10 mV	5 mV
10 ⁶	.03 ms	3 mV	2 mV
10 ⁵	.01 ms	3 mV	2 mV
10 ⁴	.01 ms	3 mV	2 mV

33

TABLE 7-4.

Oscilloscope	Wavetek Frequency	427 Rise Time Setting	Max 10-90% Rise Time
10 μ s	10 kHz	.01 ms	.015 ms
10 μ s	1 kHz	.03 ms	.040 ms
.1 ms	1 kHz	.1 ms	.15 ms
.1 ms	100 Hz	.3 ms	.37 ms
1 ms	100 Hz	1 ms	1.1 ms
1 ms	10 Hz	3 ms	3.7 ms
10 ms	10 Hz	10 ms	11 ms
10 ms	10 Hz	30 ms	37 ms

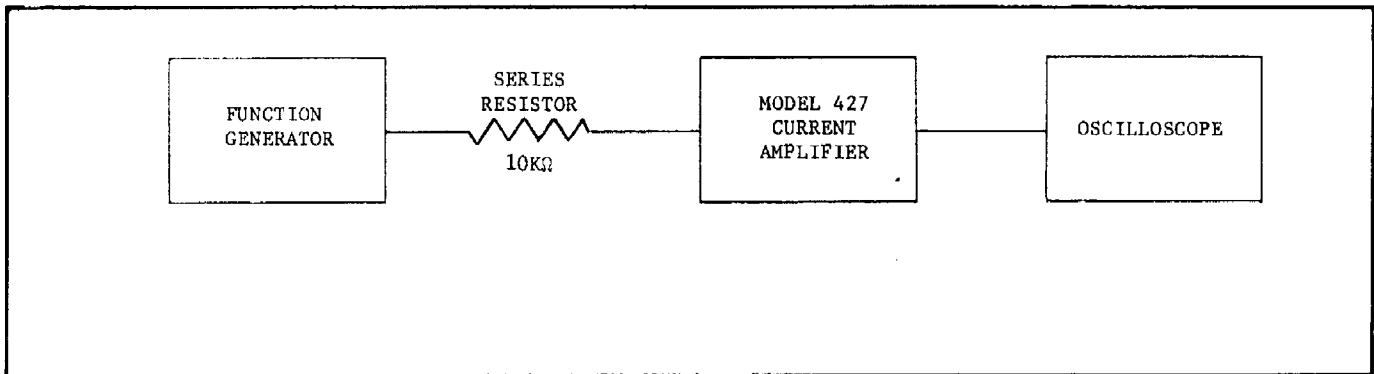

FIGURE 25. Measurement of Filter Rise Time.

b). Set the Model 427 gain to 10^4 V/A. Using the series resistor (10^4) and the square wave frequency listed, check the filter amplifier 10-90% rise time. Set the Function Generator amplitude as needed to obtain a 10 volt peak-to-peak output from the Model 427. The overshoot and dipping or a combination of both should not exceed $\pm 10\%$. Trigger the Oscilloscope from the Function Generator Sync output.

c). Set the Oscilloscope for .2V/Div and set the Function Generator for 1 volt out of the Model 427. Using the square wave frequency listed below check the 10%-90% rise time of the filter amplifier.

TABLE 7-5.

Oscilloscope	Wavetek Frequency	427 Rise Time Setting	Max 10-90% Rise Time
.1 sec	1 Hz	100 ms	110 ms
.1 sec	1 Hz	300 ms	370 ms

34

b. Final Calibration.

1. Gain Accuracy.

a). Connect the Model 261 Picoampere Source to the input of the Model 427 and connect the Model 163 to the Model 427 output. Set the Model 427 Time Constant to 300 ms.

b). Set the Model 163 on the 1 volt range and step the Model 261 and Model 427 through the ranges in Table 7-6. The DVM readings must be within the range given. For positive current inputs the voltage output is negative.

TABLE 7-6.

261	427 Gain	Model 163
10×10^5	10^4 V/A	.98V to 1.02V
1×10^5	10^5	.98V to 1.02V
1×10^6	10^6	.98V to 1.02V
1×10^7	10^7	.98V to 1.02V
1×10^8	10^8	.98V to 1.02V
1×10^9	10^9	.98V to 1.02V
1×10^{10}	10^{10}	.96V to 1.04V
1×10^{11}	10^{11}	.96V to 1.04V

2. Offset Current

a). Re-check the current amplifier and filter amplifier zero. Place a CAP-18 on the Model 427 input and set the Model 427 Gain to 10^{11} V/A and Rise Time to 300 ms.

b). Connect the Model 163 to the Model 427 output and set it to the 1 volt range. The reading on the Model 163 should be less than 100 mV.

3. Current Suppression.

a). Place a CAP-18 on the Model 427 input and set the gain to 10^{11} V/A. Connect Model 163 to the Model 427 output and set it to the 10 volt range.

b). Set the Model 427 Suppression switch to 10^{-10} , set the Polarity to (+) and the Fine control to obtain a -10 volt ± 10 mV reading on the Model 163.

c). Step the Suppression and Gain switches through the positions in Table 7-7. The readings on the Model 163 should be within the tolerance given:

TABLE 7-7.

GAIN V/A	SUPPRESSION	MODEL 163
10^{11}	10^{-10}	-10V ± 10 mV
10^{10}	10^{-9}	-10V ± 600 mV
10^9	10^{-8}	-10V ± 600 mV
10^8	10^{-7}	-10V ± 600 mV
10^7	10^{-6}	-10V ± 600 mV
10^6	10^{-5}	-10V ± 600 mV
10^5	10^{-4}	-10V ± 600 mV
10^4	10^{-3}	-10V ± 600 mV
		-10V ± 3 V

d). Repeat steps b and c with the suppression polarity switch in the (-) position. The Model 163 readings will now be positive.

4. Drift.

a). Set the Model 427 controls as follows:

GAIN: 10^5 V/A
 SUPPRESSION: 10^{-7} ampere
 RISE TIME: 1 ms
 POLARITY: (+) or (-)*

*POLARITY is (+) for setting recorder printer left of zero and (-) for setting recorder printer right of zero.

b). Set the recorder sensitivity to 10 mV full scale and using the suppression FINE control set the recorder printer to a convenient spot for recording drift of the Model 427.

c). After a 1 hour warm-up the Model 427 should drift no more than ± 500 μ V (five minor divisions) in any subsequent 24 hour period ± 500 μ V/ $^{\circ}$ C.

CODE-TO-NAME LIST

CODE TO NAME List of Suggested Manufacturers.

Reference: Federal Supply Code for Manufacturers, Cataloging Handbook H4-2.

00656	Aerovox Corp. 740 Belleville Ave. New Bedford, Mass. 02741	07137	Transistor Electronics Corp. Hwy. 169 - Co. Rd. 18 Minneapolis, Minn. 55424	14659	Sprague Electric Co. P.O. Box 1509 Visalia, Calif. 93278
00686	Film Capacitors, Inc. 100 Eighth St. Passaic, N.J.	07263	Fairchild Camera & Inst. Corp. 313 Frontage Road Mountain View, Calif.	15238	ITT Semiconductors Div. of ITT Corp. Lawrence, Mass. 01841
01121	Allen-Bradley Corp. 1201 South 2nd St. Milwaukee, Wisc. 53204	07716	IRC, Inc. 2850 Mt. Pleasant Burlington, Iowa 52601	15909	Daven Div. of T.A. Edison Ind. McGraw Edison Co. Livingston, N.J.
01295	Texas Instruments, Inc. Semiconductor-Components Div. Dallas, Texas 75231	08811	GL Electronics Div. of GL Industries, Inc. Westville, N.J. 08093	16170	Teladyne Systems Co. Communications Div. Los Angeles, Calif. 90066
01686	RCL Electronics, Inc. 195 McGregor St. Manchester, N.H. 03102	09052	Gulton Industries, Inc. Alkaline Battery Div. Metuchen, N.J.	17554	Components, Inc. Smith St. Biddeford, Ma. 04005
02101	Varo Inc. Electrokinetics Div. Santa Barbara, Calif. 93102	09823	Burgess Battery Co. Div. of Servel Inc. Freeport, Ill.	23020	General Reed Co. 174 Main St. Metuchen, N.J. 08840
02660	Amphenol Corp. 2801 South 25th Ave. Broadview, Ill. 60153	09922	Burndy Corp. Richards Ave. Norwalk, Conn. 06852	24655	General Radio Co. 22 Baker Ave. West Concord, Mass. 01781
02734	Radio Corp. of America Defense Electronic Products Camden, N.J.	10582	CTS of Asheville Inc. Mills Gap Road Skyland, N.C.	27682	Hathaway Instruments, Inc. 5800 E. Jewell Ave. Denver, Colorado 80222
02735	Radio Corp. of America Receiving Tube Div. Somerville, N.J.	11502	IRC Inc. Greenway Road Boone, N.C. 28607	28520	Heyman Mfg. Co. 147 N. Michigan Ave. Kenilworth, N.J.
02777	Hopkins Engineering Co. 12900 Foothill Blvd. San Fernando, Calif. 91342	11837	Electro Scientific Indus., Inc. 13645 NW Science Park Dr. Portland, Or. 97229	29309	Richey Electronics Inc. 1307 Dickerson Rd. Nashville, Tenn. 37213
02985	Tepro Electric Corp. 5 St. Paul St. Rochester, N.Y. 14604	12040	National Semiconductor Corp. Commerce Drive Danbury, Conn. 06813	35529	Leeds and Northrup 4901 Stenton Ave. Philadelphia, Pa. 19144
03508	General Electric Co. Semiconductor Products Dept. Syracuse, N.Y. 13201	12065	Transitron Electronic Corp. 144 Addison St. East Boston, Mass.	37942	Mallory, P. R. and Co., Inc. 3029 E. Washington St. Indianapolis, Ind. 46206
04009	Arrow-Hart & Hegeman Electric Co. 103 Hawthorne St. Hartford, Conn. 06106	12697	Clarostat Mfg. Co., Inc. Lower Washington St. Dover, N.H. 03820	44655	Ohmite Mfg. Co. 3601 Howard St. Skokie, Ill. 60076
04713	Motorola Semiconductor Prod. Inc. 5005 E. McDowell Rd. Phoenix, Ariz. 85008	12954	Dickson Electronics Corp. 302 S. Wells Fargo Ave. Scottsdale, Ariz.	53201	Sangamo Electric Co. 1301 North 11th Springfield, Ill. 62705
05079	Transistor Electronics, Inc. 1000 West Road Bennington, Vt. 05201	13050	Potter Co. Highway 51 N. Wesson, Miss. 39191	54294	Shallcross Mfg. Co. 24 Preston St. Selma, N.C.
05397	Union Carbide Corp. Electronics Div. New York, N.Y. 10017	13327	Solitron Devices, Inc. 256 Oak Tree Road Tappan, N.Y. 10983	56289	Sprague Electric Co. North Adams, Massachusetts
06751	Components, Inc. Arizona Div. Phoenix, Ariz. 85019	13934	Midwec Corp. 602 Main Oshkosh, Nebr. 69154	58474	Superior Electric Co., The 383 Middle St. Bristol, Conn. 06012
06980	Varian Assoc. EIMAC Div. 301 Industrial Way San Carlos, Calif. 94070	14655	Cornell-Dubilier Electric Corp. 50 Paris Street Newark, N.J.	61637	Union Carbide Corp. 270 Park Ave. New York, N.Y. 10017

CODE TO NAME List (Continued).

63060	Victoreen Instrument Co. 5806 Hough Ave. Cleveland, Ohio 44103	75042	IRC Inc. 401 North Broad St. Philadelphia, Pa. 19108	86684	Radio Corp. of America Electronic Components & Devices Harrison, N.J.
70309	Allied Control Co., Inc. 2 East End Ave. New York, N.Y.	75915	Littlefuse, Inc. 800 E. Northwest Hwy. Des Plaines, Ill. 60016	87216	Philco Corp. Lansdale Div., Church Rd. Lansdale, Pa. 19446
70903	Belden Mfg. Co. 415 So. Kilpatrick Chicago, Ill. 60644	76055	Mallory Controls, Div. of Mallory P. R. & Co., Inc. Frankfort, Ind.	90201	Mallory Capacitor 3029 East Washington Indianapolis, Ind. 46206
71002	Birnback Radio Co., Inc. 147 Hudson St. New York, N.Y.	76493	Miller, J. W. Co. 5915 S. Main St. Los Angeles, Calif. 90003	90303	Mallory Battery Co. Tarrytown, New York
71279	Cambridge Thermionic Corp. 430 Concord Avenue Cambridge, Mass.	76545	Mueller Electric Co. 1583 E. 31st St. Cleveland, Ohio 44114	91637	Dale Electronics, Inc. P.O. Box 609 Columbus, Nebr. 68601
71400	Bussmann Mfg. Div. of McGraw-Edison Co. St. Louis, Mo.	77764	Resistance Products Co. 914 S. 13th St. Harrisburgh, Pa. 17104	91662	Elco Corp. Willow Grove, Pennsylvania
71450	CTS Corp. 1142 W. Beardsley Ave. Elkhart, Ind.	79727	Continental-Wirt Electronics Corp. Philadelphia, Pa.	91737	Gremar Mfg. Co., Inc. 7 North Ave. Wakefield, Mass.
71468	ITT Cannon Electric, Inc. 3208 Humbolt St. Los Angeles, Calif. 90031	80164	Keithley Instruments, Inc. 28775 Aurora Road Cleveland, Ohio 44139	91802	Industrial Devices Inc. 982 River Rd. Edgewater, N.J. 07020
71590	Centralab Div. of Globe-Union, Inc. Milwaukee, Wisc. 53212	80294	Bourns, Inc. 6135 Magnolia Ave. Riverside, Calif. 92506	91929	Honeywell Inc. Micro Switch Div. Freeport, Ill. 61032
71785	Cinch Mfg. Co. and Howard B. Jones Div. Chicago, Ill. 60624	81073	Grayhill, Inc. 561 Hillgrove Ave. La Grange, Ill. 60525	93332	Sylvania Electric Products, Inc. Semiconductor Products Div. Woburn, Mass.
72619	Dialight Corp. 60 Stewart Ave. Brooklyn, N.Y. 11237	81483	International Rectifier Corp. 1523 East Grand Ave. El Segundo, Calif.	93656	Electric Cord Co. 1275 Bloomfield Ave. Caldwell, N.J.
72653	G-C Electronics Co. 400 S. Wyman Rockford, Ill. 61101	82389	Switchcraft, Inc. 5527 N. Elston Ave. Chicago, Ill. 60630	94144	Raytheon Co., Industrial Operation Components Div. Quincy, Mass.
72699	General Instrument Corp. Capacitor Division Newark, N.J. 07104	83125	General Instrument Corp. Capacitor Division Darlington, S.C. 29532	94154	Tung-Sol Electric, Inc. Newark, New Jersey
72982	Erie Technological Prods Inc. 644 W. 12th St. Erie, Pa. 16512	83330	Smith, Herman H., Inc. 812 Snediker Ave. Brooklyn, N.Y. 11207	94310	Tru-Ohm Products Memcor Components Div. Huntington, Ind. 46750
73138	Beckman Instruments, Inc. Helipot Division Fullerton, Calif. 92634	83594	Burroughs Corp. Electronic Components Div. Plainfield, N.J. 07061	94696	Magnecraft Electric Co. 5579 North Lynch Chicago, Ill.
73445	Amperex Electronic Co., Div. of North American Philips Co., Inc. Hicksville, N.Y.	83701	Electronic Devices, Inc. Brooklyn, New York	95348	Gordos Corp. 250 Glenwood Ave. Bloomfield, N.J. 07003
73690	Elco Resistor Co. 1158 Broadway New York, N.Y.	84171	Arco Electronics, Inc. Community Drive Great Neck, N.Y. 11022	95712	Dage Electric Co., Inc. Hurricane Road Franklin, Ind.
74276	Signalite Inc. 1933 Heck Ave. Neptune, N.J. 07753	84411	TRW Capacitor Div. 112 W. First St. Ogallala, Nebr.	97933	Raytheon Co. Components Div. Semiconductor Operation Mountain View, Calif.
74970	Johnson, E. F., Co. 297 Tenth Ave. S.W. Waseca, Minn. 56093	84970	Sarkes Tarzian, Inc. E. Hillside Dr. Bloomington, Ind.	99120	Plastic Capacitors, Inc. 2620 N. Clybourn Ave. Chicago, Ill.

Boyd
 11.5
 10 x 10
 5.80

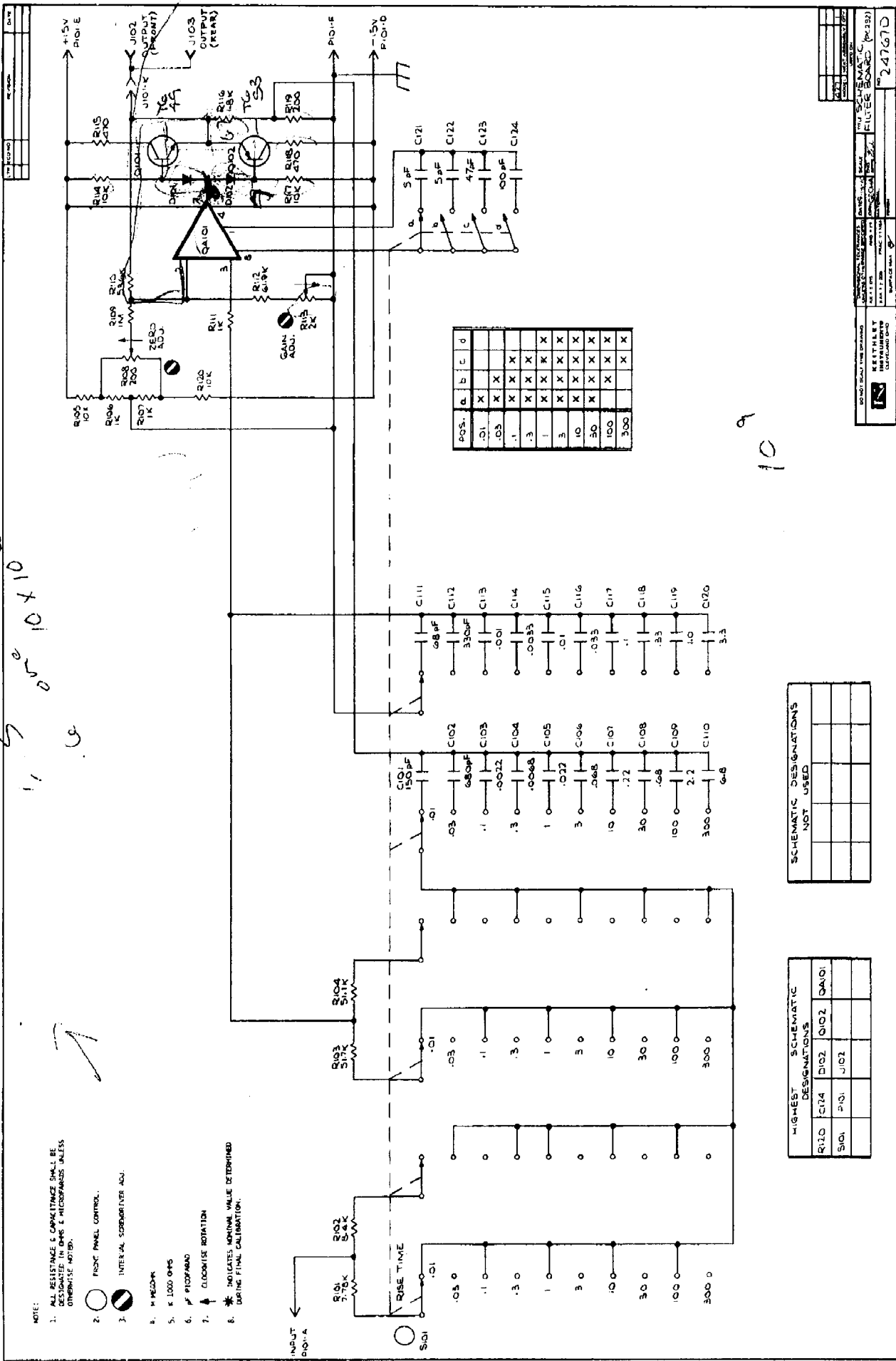

- NOTE:
1. ALL RESISTANCE & CAPACITANCE SHALL BE DESIGNATED IN OHMS & MICROOHMS UNLESS OTHERWISE NOTED.
 2. POTENTIOMETER CONTROL.
 3. INTERNAL SCREWDRIVER ADJ.
 4. 1/4 WATT.
 5. K, 1,000 OHMS
 6. μ F MICROFARAD
 7. CLOCKWISE ROTATION
 8. * INDICATES MINIMUM VALUE DETERMINED DURING FINAL CALIBRATION.

POS.	a	b	c	d
.01	X	X	X	X
.03	X	X	X	X
.1	X	X	X	X
.3	X	X	X	X
1	X	X	X	X
3	X	X	X	X
10	X	X	X	X
30	X	X	X	X
100	X	X	X	X
300	X	X	X	X

COMPONENT	VALUE	DESIGNATION
C101	.01	C101
C102	.03	C102
C103	.1	C103
C104	.3	C104
C105	1	C105
C106	3	C106
C107	10	C107
C108	30	C108
C109	100	C109
C110	300	C110
C111	.01	C111
C112	.03	C112
C113	.1	C113
C114	.3	C114
C115	1	C115
C116	3	C116
C117	10	C117
C118	30	C118
C119	100	C119
C120	300	C120
C121	5 pF	C121
C122	5 pF	C122
C123	47 pF	C123
C124	100 pF	C124

HIGHEST SCHEMATIC DESIGNATIONS

R10	D102	D102	QA101

SCHEMATIC DESIGNATIONS NOT USED

R10	D102	D102	QA101

HIGHEST SCHEMATIC DESIGNATIONS

R10	D102	D102	QA101

SCHEMATIC DESIGNATIONS NOT USED

R10	D102	D102	QA101

10
 9

SCHEMATIC BOARD (P-282)
 PART 1 OF 2
 INSTRUMENT
 247670

Slow response shifting
to overload like

39

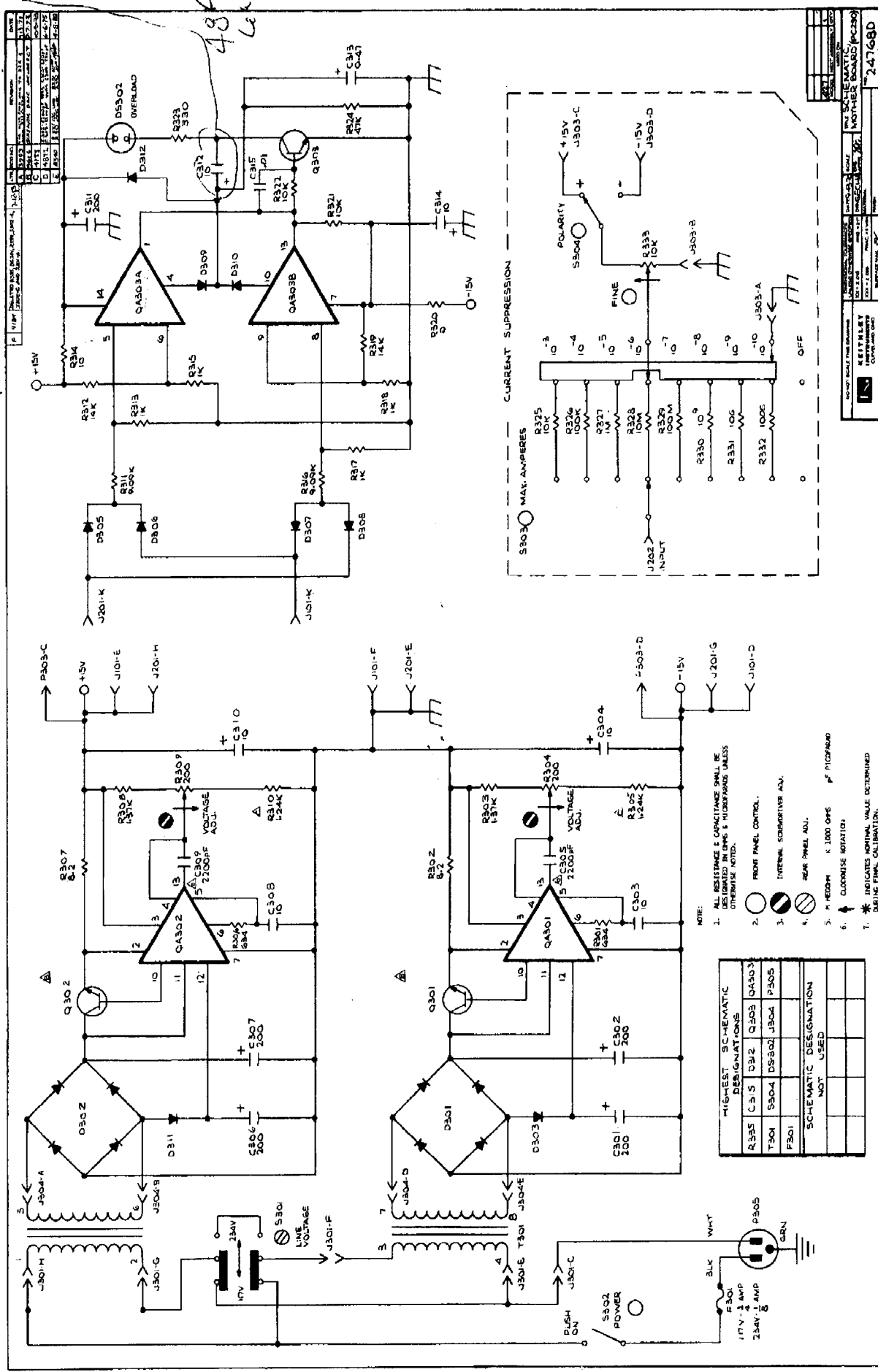

NOTE:
1. ALL RESISTANCE & CAPACITANCE SHALL BE DESIGNATED IN OHMS & KILOHMS UNLESS OTHERWISE NOTED.
2. FRONT PANEL CONTROL.
3. INTERNAL SCREWDRIVER AU.
4. REAR PANEL AU.
5. K 1000 OHMS
6. COUNTERCLOCKWISE ROTATION
* INDICATES NOMINAL VALUE DETERMINED DURING FINAL CALIBRATION.

HIGHEST SCHEMATIC DESIGNATIONS	SCHEMATIC DESIGNATION NOT USED
R335	C315
T301	D312
PS01	Q303
	Q4303
	Q4304
	P305

247-68D

REVISIONS

DATE

BY

DESCRIPTION

247-68D

247-68D

3/4
5/18

KEITHLEY

**Instruction Manual Addendum
Model 427 Current Amplifier**

The following change information is provided as a supplement to this manual in order to provide the user with the latest improvements and changes to the manual in the least amount of time. It is recommended that this information be incorporated into the appropriate places in the manual immediately.

Replace the information contained in step 8, page 28, under Amplifier Rise Time, with the following procedure:

8. Amplifier Rise Time

- a. Connect the Function Generator to the Model 427 input and connect the Model 427 rear panel output to the oscilloscope using the test setup shown in Figure 24.
- b. Adjust the 10^9 through 10^{11} ranges within the specified 10% — 90% rise time using the triangular wave frequency and adjustment listed in Table 7-2. Adjust the Function Generator, as needed, to obtain a 10 Volt p-p output from the Model 427.
- c. Without altering the test set-up, verify that the 10^6 through 10^8 ranges meet the rise time specifications in Table 7-2. Adjust the Function Generator, as required to obtain a 10 Volt p-p output from the Model 427. There should be no overshoot on any range.
- d. Remove the 100pF capacitor from the test set-up and connect the Function Generator directly to the Model 427 input. Verify the 10^4 through 10^5 10% — 90% rise time, using the square wave frequency, per Table 7-2. There should be no overshoot on any range except for the 10^4 V/A which should be less than 10% overshoot.

Model 427 Current Amplifier Addendum

INTRODUCTION

This addendum to the Model 427 Current Amplifier Instruction Manual is being provided in order to supply you with the latest information in the least possible time. Please incorporate this information into the manual immediately.

Page 3; Note that in Figure 2 the dials on the knobs are now black.

Page 20; Replace Table with the following:

FILTER BOARD
("100" SERIES, PC-291*, PC-292)

CAPACITORS

Circuit Desig.	Value	Rating	Type	Mfr. Code	Mfr. Desig.	Keithley Part No.	Fig. Ref.
C101	150pF	500V	Poly	71590	CPR-150J	C138-150P	19
C102	680pF	500V	Poly	71590	CPR-680J	C138-680P	19
C103	.0022μF	500V	Poly	71590	CPR-2200J	C138-.0022M	19
C104	6800pF	500V	Poly	71590	CPR-6800J	C138-6800P	19
C105	.022μF	200V	Poly	84171	2PJ-223G	C108-.022M	19
C106	.068μF	100V	My	88480	3FR-683-1E	C146-.068M	19
C107	.22μF	200V	My	13050	SM1A-.22μF	C47-.22mF	19
C108	.68μF	200V	My	13050	SM1A-.68μF	C47-.68mF	19
C109*	2.2μF	200V	My	13050	SM1A-2.2μF	C47-2.2M	16
C110*	6.8μF	200V	My	97419	M2WF-6.8μF	C203-6.8M	16
C111	68pF	500V	Poly	71590	CPR-68J	C138-68P	19
C112	330pF	500V	Poly	71590	CPR-330J	C138-330P	19
C113	.001μF	500V	Poly	71590	CPR-1000J	C138-.001M	19
C114	.0033μF	500V	Poly	71590	CPR-3300J	C138-.0033M	19
C115*	.01μF	200V	Poly	84171	2PJ-103G	C108-.01M	16
C116	.033μF	100V	My	88480	3FR-333-1E	C146-.033M	19
C117	.1μF	200V	My	13050	SM1A-.1μF	C47-.1M	19
C118	.33μF	200V	My	13050	SM1A-.33μF	C47-.33M	19
C119*	1μF	200V	My	13050	SM1A-1μF	C47-1M	16
C120*	3.3μF	200V	My	13050	SM1A-3.3μF	C47-3.3M	16
C121	5pF	1000V	CerD	72982	DD-050	C64-5P	19
C122	5pF	1000V	CerD	72982	DD-050	C64-5P	19
C123	33pF	100V	CerD	72982	DD-330	C64-33P	19
C124	100pF	100V	CerD	72982	DD-101	C64-100P	19

MISCELLANEOUS

Circuit Desig.	Type	Mfr. Code	Mfr. Desig.	Keithley Part No.	Fig. Ref.
J101	Connector, 10-Pin, Mini-PV	22526	20052	CS-237	19
QA101	Integrated Circuit	12040	LM301AN	IC-24	19
D101	Diode, Rectifier	01295	1N914	RF-28	19
D102	Diode, Rectifier	01295	1N914	RF-28	19
Q101	Transistor	04713	2N3903	TG-49	19
Q102	Transistor	04713	2N3905	TG-53	19
S101	Switch, Rotary, RISE TIME Knob, Rise Time	80164	SW-338	SW-338	19
J102	Connector, BNC, UG1094A/U			KN-46	2
—	Cap, BNC, mates with J102	02660	31-2221	CS-249	3
				CAP-18	—

RESISTORS

Circuit Desig.	Value	Rating	Type	Mfr. Code	Mfr. Desig.	Keithley Part No.	Fig. Ref.
R101	7.78kΩ	1%, 1/8W	MtF	07716	CEA-7.78KΩ	R88-7.78k	19
R102	8.41kΩ	1%, 1/8W	MtF	07716	CEA-8.41KΩ	R88-8.41k	19
R103	51.7kΩ	1%, 1/8W	MtF	07716	CEA-51.7KΩ	R88-51.7k	19
R104	51.7kΩ	1%, 1/8W	MtF	07716	CEA-52.7KΩ	R88-51.7k	19
R105	10kΩ	1%, 1/8W	MtF	07716	CEA-10KΩ	R88-10k	19

Page 22; Replace Table with the following:

AMPLIFIER BOARD (cont'd)

DIODES

Circuit Desig.	Type	Mfr. Code	Mfr. Desig.	Keithley Part No.	Fig. Ref.
D201	Special	80164	24555A	24555A	18
D202	Special	80164	24555A	24555A	18
D203	Silicon, NPN, Case TO-106	07263	2N3565	TG-39	18
D204	Silicon, NPN, Case	07263	2N3565	TG-39	18
D205	—	01295	1N645	RF-14	18
D206	—	01295	1N645	RF-14	18
D207	Silicon	01295	1N914	RF-28	18
D208	Silicon	01295	1N914	RF-28	18
D209	Silicon	01295	1N914	RF-28	18
D210	Silicon	01295	1N914	RF-28	18

MISCELLANEOUS

Circuit Desig.	Type	Mfr. Code	Mfr. Desig.	Keithley Part No.	Fig. Ref.
QA201	Integrated Circuit, Operational Amplifier	07263	μA715C	IC-26	18
S201	Switch, Rotary, GAIN Knob, Gain	80164	SW-337	SW-337 KN-46	18 2
J201	Not Used				
J202	Receptacle, BNC (UG-1094A/U)	02660	31-2221	CS-249	18

RESISTORS (*Located on Switch S201)

Circuit Desig.	Value	Rating	Type	Mfr. Code	Mfr. Desig.	Keithley Part No.	Fig. Ref.
R201	10Ω	10%, 1/4W	Comp	44655	RC07	R76-10	18
R202	1MΩ	10%, 1/2W	Comp	01121	EB-1M	R1-1M	18
R203	100kΩ	1%, 1/8W	MtF	07716	CEA-100kΩ	R88-100k	18
R204	23.2kΩ	1%, 1/8W	MtF	07716	CEA-23.2kΩ	R88-23.2k	18
R205	22.1kΩ	1%, 1/8W	MtF	07716	CEA-22.1kΩ	R88-22.1k	18
R206	10kΩ	1%, 1/8W	MtF	07716	CEA-10kΩ	R88-10k	18
R207	18.2kΩ	1%, 1/2W	MtF	07716	CEC-18.2kΩ	R94-18.2k	18
R208	10kΩ	1%, 1/8W	MtF	07716	CEA-10kΩ	R88-10k	18
R209	12.1kΩ	1%, 1/8W	MtF	07716	CEA-12.1kΩ	R88-12.1k	18
R210	499Ω	1%, 1/8W	MtF	07716	CEA-499Ω	R88-499	18
R211	499Ω	1%, 1/8W	MtF	07716	CEA-499Ω	R88-499	18
R212	10Ω	1%, 1/8W	MtF	07716	CEA-10Ω	R88-10	18
R213	470Ω	10%, 1/4W	Comp	44655	RC07-471	R76-470	18
R214	10kΩ	1%, 1/8W	MtF	07716	CEA-10kΩ	R88-10k	18
R215	470Ω	10%, 1/4W	Comp	44655	RC07-471	R76-470	18
R216	10Ω	10%, 1/4W	Comp	44655	RC07-100	R76-10	18
R217	10Ω	10%, 1/4W	Comp	44655	RC07-100	R76-10	18
R218*	270kΩ	10%, 1/2W	Comp	01121	EB-270kΩ	R1-270k	20
R219*	100Ω	1%, 1/2W	MtF	07716	CEC-100Ω	R94-100	20
R220*	900Ω	1%, 1/2W	DCb	91637	DCF-1/2-900Ω	R12-900	20
R221*	10kΩ	1%, 1/2W	MtF	07716	CEC-10kΩ	R94-10k	20
R222*	100kΩ	1%, 1/2W	MtF	07716	CEC-100kΩ	R94-100k	20
R223*	1MΩ	1%, 1/2W	MtF	07716	CEC-1MΩ	R94-1M	20
R224	10MΩ	1%, 1W	DCb	91637	DC-1-10MΩ	R13-10M	20
R225	10 ⁶ Ω	1%, 2W	DCb	91637	DC-2-10 ⁶ Ω	R14-10 ⁶	20

44

Page 24; Replace Table with the following:

MOTHER BOARD (cont'd)

DIODES (cont'd)

Circuit Desig.	Type	Mfr. Code	Mfr. Desig.	Keithley Part No.	Fig. Ref.
D308	Silicon	01295	1N914	RF-28	17
D309	Silicon	01295	1N914	RF-28	17
D310	Silicon	01295	1N914	RF-28	17
D311	Silicon	01295	1N645	RF-14	17
D312	Silicon	01295	1N914	RF-28	—

MISCELLANEOUS

Circuit Desig.	Type	Mfr. Code	Mfr. Desig.	Keithley Part No.	Fig. Ref.
J301	Connector, Mini-PV	22526	47439	CS-236	17
J302	Connector, Mini-PV	22526	47439	CS-236	17
QA301	Integrated Circuit, Voltage Regulator	07263	UGA7723393	IC-25	17
QA302	Integrated Circuit, Voltage Regulator	07263	UGA7723393	IC-25	17
QA303	Integrated Circuit	07263	A749C	IC-27	17
S301	Switch, Line Voltage	80164	SW-318	SW-318	3
S302	Switch, "PUSH ON" Power with lamp	80164	PBL-5-BSA3C7A	SW-340	3
S303	Switch, CURRENT SUPPRESS	80164	SW-339	SW-339	20
	Knob Amperes			KN-46	2
Q301	Transistor	02735	40312	TG-54	17
Q302	Transistor	02735	40312	TG-54	17
Q303	Transistor, Silicon, NPN, TO-92 Case	04713	2N3903	TG-49	17
S304	Switch POLARITY	80164	SW-236	SW-236	3
F301	Fuse, 117V, .25a, Slo-Blo, 3AG	75915	313.250	FU-17	3
F301	Fuse, 234V, 1/8A, Slo-Blo, 3AG	71400	MDL	FU-20	3
T301	Transformer	80164	TR-138	TR-138	20
P305	Receptacle, AC	82389	AC3G	CS-235	3
—	Line cord, mates with P305	70903	17258-S	CO-7	—
DS-301	Pilot lamp, neon (replacement for S302)	08806	C7A (NE-2P)	PL-58	—
DS-302	Pilot Lamp, OVERLOAD	07294	CF03ACS1869	PL-51	2
	Knob, Fine Adjust			KN-58	2

RESISTORS (*Located on Switch S303)

Circuit Desig.	Value	Rating	Type	Mfr. Code	Mfr. Desig.	Keithley Part No.	Fig. Ref.
R301	634Ω	1%, 1/8W	MtF	07716	CEA-634Ω	R88-634	17
R302	8.2Ω	5%, 1/2W	Comp	01121	EB-8.2Ω	R19-8.2	17
R303	1.37kΩ	1%, 1/8W	MtF	07716	CEA-1.37kΩ	R88-1.37k	17
R304	200Ω	0.5W	—	80294	3329P-200	RP-88-200	17
R305	1.24kΩ	1%, 1/8W	MtF	07716	CEA-1.1kΩ	R88-1.24	17
R306	634Ω	1%, 1/8W	MtF	07716	CEA-634Ω	R88-634	17
R307	8.2Ω	5%, 1/2W	Comp	01121	EB-8.2Ω	R19-8.2	17
R308	1.37kΩ	1%, 1/8W	MtF	07716	CEA-1.37kΩ	R88-1.371	17
R309	200Ω	0.5W	—	80294	3329P-200	RP-98-200	17
R310	1.24kΩ	1%, 1/8W	MtF	07716	CEA-1.1kΩ	R88-1.24	17
R311	9.09kΩ	1%, 1/8W	MtF	07716	CEA-9.09kΩ	R88-9.09k	17
R312	14kΩ	1%, 1/8W	MtF	07716	CEA-14kΩ	R88-14k	17
R313	1kΩ	1%, 1/8W	MtF	07716	CEA-1kΩ	R88-1k	17
R314	10kΩ	10%, 1/4W	Comp	44655	RC07-100	R76-10	17
R315	1kΩ	1%, 1/8W	MtF	07716	CEA-1kΩ	R88-1k	17
R316	9.09kΩ	1%, 1/8W	MtF	07716	CEA-9.09kΩ	R88-9.09k	17
R317	1kΩ	1%, 1/8W	MtF	07716	CEA-1kΩ	R88-1k	17
R318	1kΩ	1%, 1/8W	MtF	07716	CEA-1kΩ	R88-1k	17
R319	14kΩ	1%, 1/8W	MtF	07716	CEA-14kΩ	R88-14k	17
R320	10Ω	10%, 1/4W	Comp	44655	RC07-100	R76-10	17
R321	10kΩ	10%, 1/4W	Comp	44655	RC07-103	R76-10k	17
R322	10kΩ	10%, 1/4W	Comp	44655	RC07-103	R76-10k	17
R323	330Ω	10%, 1/4W	Comp	44655	RC07-331	R76-330	17
R324	47kΩ	10%, 1/4W	Comp	44655	RC07-473	R76-47k	17
R325*	10kΩ	1%, 1/2W	MtF	07716	CEC-10kΩ	R94-10k	20

HOW TO INSTALL IC-388

SINCE THE IC-388 IS A 8 PIN DEVICE SET UP ACCORDING.

CUT PIN 5 OF THE IC-388.

- A. PIN 1 OF THE OP AMP GOES INTO THE HOLE OF PIN 2.
- B. PIN 2 OF THE OP AMP GOES INTO THE HOLE OF PIN 3.**
- C. PIN 3 OF THE OP AMP GOES INTO THE HOLE OF PIN 4.
- D. PIN 4 OF THE OP AMP GOES INTO THE HOLE OF PIN 5.
- E. PIN 6 OF THE OP AMP GOES INTO THE HOLE OF PIN 6.**
- F. PIN 7 OF THE OP AMP GOES INTO THE HOLE OF PIN 8.
- G. PIN 8 OF THE OP AMP GOES INTO THE HOLE OF PIN 10.

PIN HOLES 1,7,9 WILL REMAIN EMPTY.

ON THE REVERSE SIDE OF THE PC-289 INSTALL A CAPACITOR C-64-22PF BETWEEN PINS 3 AND 6 OF PC BOARD. **

CHANGE R210 AND R211 FORM R-88-1K TO R-88-3.01K.

REMOVE CAPACITORS C-207,C-208 AND C-209 FROM THE CIRCUIT BOARD. THEY ARE NO LONGER NEEDED.

SEE ATTACHED DRAWING.

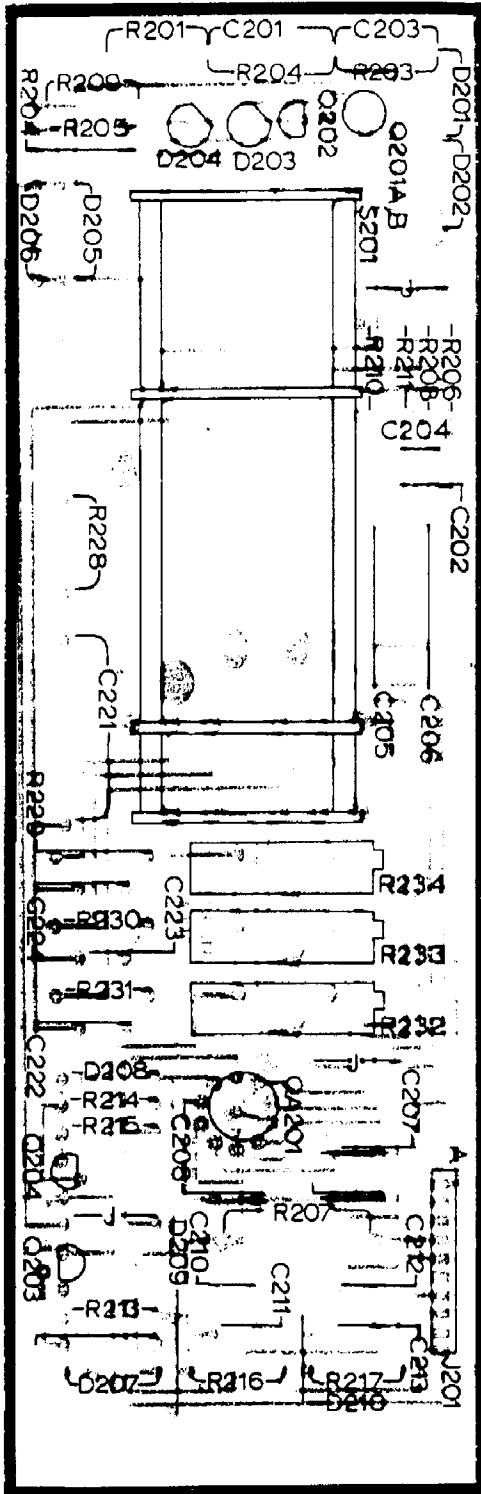

FIGURE 18.
Component Layout - PC-289.

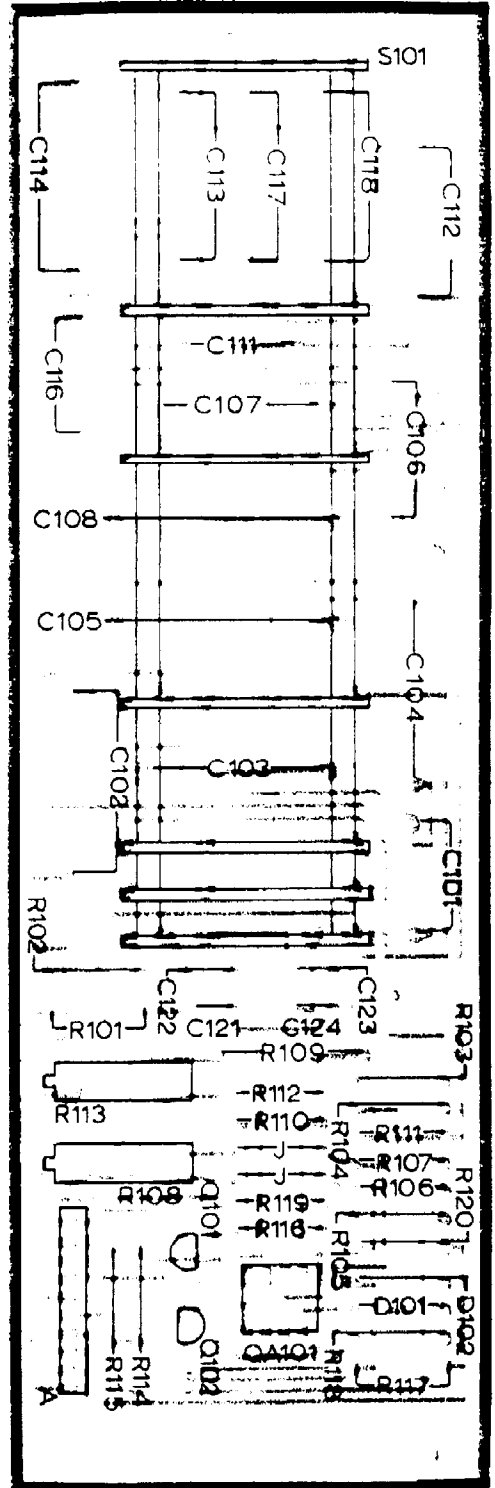

FIGURE 19.
Component Layout - PC-292.

47



SERVICE FORM

Model No. _____ Serial No. _____ P.O. No. _____ Date _____

Name _____ Phone _____

Company _____

Address _____

City _____ State _____ Zip _____

List all control settings and describe problem. _____

(Attach additional sheets as necessary.)

Show a block diagram of your measurement system including all instruments connected (whether power is turned on or not). Also describe signal source.

Where is the measurement being performed? (factory, controlled laboratory, out-of-doors, etc.) _____
What power line voltage is used? _____ Variation? _____
Frequency? _____ Ambient Temperature? _____ °F.
Variation? _____ °F. Rel. Humidity? _____ Other? _____

Any additional information. (If special modifications have been made by the user, please describe below.)

*Be sure to include your name and phone number on this service form.